



This manual covers installation and operating instructions for the following 3Com modems:

U.S. Robotics 56 Kbps* Voice internal and external modems

3Com, the 3Com logo, and U.S. Robotics are registered trademarks and *Connections*, RapidComm, and x2 are trademarks of 3Com Corporation or its subsidiaries. Windows is a registered trademark of Microsoft Corp. CompuServe is a registered trademark of CompuServe Inc. America Online is a registered trademark of America Online Inc. Any other trademarks, trade names, or service marks used in this manual are the property of their respective owners.

© 1998 3Com Corporation
7770 North Frontage Road
Skokie, IL 60077-2690
All Rights Reserved

- * **IMPORTANT!** In accordance with the ITU-T standard for 56K transmissions, this modem is capable of 56 Kbps downloads. However, due to FCC rules which restrict power output of the service providers' modems, current download speeds are limited to 53 Kbps. Actual speeds may vary depending on line conditions and other factors. Uploads from users to server equipment travel at speeds up to 31.2 Kbps. An analog phone line compatible with the ITU-T 56K standard or x2™ technology, and an Internet provider or corporate host site compatible with the ITU-T 56K standard or x2 technology are necessary for these high-speed downloads.

TABLE OF CONTENTS

Welcome to 56K Information Access	1
Product Features	2
Before You Begin (Windows 95 Users)	3
Determining Available Resources	3
Determining Your Version of Windows 95	4
Internal Modem Installation with Windows 3.x	5
A Word about COM Ports and IRQs	5
How to Use ComTest to Determine Your Modem's Settings	7
Testing an Installed Modem	9
What to Do with ComTest's Recommendation	10
How to Change the Modem's Settings	12
How to Insert the Modem into the Computer	14
Internal Modem Installation with Windows 95	21
How to Prepare for Plug and Play Installation	22
How to Insert the Modem into the Computer	23
Installing the Modem Drivers	27
External Modem Installation with Windows 95	35
Determining Which Serial Cable to Buy	35
Connecting the Modem to the Computer	37
Installing the Modem Drivers	39

TABLE OF CONTENTS

Software Installation	47
Running the Setup Wizard	47
Using Connections	48
Installing the RapidComm™ Voice Fax/Data/Voice Software	48
Installing Other Fax/Data Software	50
Type of Modem	50
Initialization String	50
Flow Control	51
UART (External Modems Only)	51
Using Modem Station	52
What Does Modem Station Do?	52
Why Modem Station?	52
Installing Modem Station	52
Starting Modem Station	55
Using Detect New Modems	57
Using Terminal	58
Using Modem Configurator	60
Using Modem to Computer	63
Using the Extended Information Screens	67

TABLE OF CONTENTS

U.S. Robotics Modem Update Wizard	74
Installing the Wizard	74
Updating Your Modem	75
Troubleshooting and Online Help Resources	76
RapidComm Voice Troubleshooting Tips	82
If Plug and Play Does Not Detect Your Modem	83
Online Help Resources	84
Are You Still Having Problems?	87
If You Need to Return the Modem to Us for Repair	87
Glossary	88
Regulatory Information	102
Manufacturer's Declaration of Conformity	102
Limited Warranty	109

WELCOME TO 56K* INFORMATION ACCESS

The International Telecommunications Union (ITU) determines the technical protocols communications devices must use to interoperate with each other. Modems that comply with ITU standards can “talk” to other standards-compliant modems and fax machines worldwide.

The ITU has determined a worldwide standard for 56K modem technology . With a U.S. Robotics modem, you can get all the Internet you want from any service provider who offers the ITU 56K standard or x2™ technology.

This modem allows the greatest compatibility for high speed downloads from service providers that offer the ITU 56K standard technology or x2 technology to their customers. 3Com is working with providers everywhere to quickly upgrade their service to the ITU 56K standard.

* In accordance with the ITU-T standard for 56K transmissions, this modem is capable of 56 Kbps downloads. However, due to FCC rules which restrict power output of the service providers' modems, current download speeds are limited to 53 Kbps. Actual speeds may vary depending on line conditions and other factors. Uploads from users to server equipment travel at speeds up to 31.2 Kbps. An analog phone line compatible with the ITU-T 56K standard or x2™ technology, and an Internet provider or corporate host site compatible with the ITU-T 56K standard or x2 technology are necessary for these high-speed downloads.

PRODUCT FEATURES

Modulation Schemes

56K ITU-T standard
x2™ technology
ITU-T V.34+
ITU-T V.34
ITU-T V.32bis
ITU-T V.32
ITU-T V.22bis
ITU-T V.22
ITU-T V.23
Bell 212A
ITU-T V.21
Bell 103

Error Control and Data Compression Schemes

ITU-T V.42
ITU-T V.42bis
MNP 2-5

Fax Modulation Schemes

ITU-T V.17
ITU-T V.29
ITU-T V.27ter
ITU-T V.21

Fax Standards

EIA 578 Class 1 FAX
EIA 592 Class 2.0 FAX

Front Channel Link Rates

28000, 29333, 30666, 32000,
33333, 34666, 36000, 37333,
38666, 40000, 41333, 42666,
44000, 45333, 46666, 48000,
49333, 50666, 52000, 53333,
54666, 56000, 57333

Back Channel Link Rates

4800, 7200, 9600, 12000, 14400,
16800, 19200, 21600, 24000,
26400, 28800, 31200
33600

V.34+ Link Rates

4800, 7200, 9600, 12000, 14400,
16800, 19200, 21600, 24000,
26400, 28800, 31200, 33600

V.32bis Link Rates

4800, 7200, 9600, 12000, 14400

Additional Link Rates

300, 1200/75 (V.23), 1200, 2400

Fax Link Rates

2400, 4800, 7200, 9600,
12000, 14400

BEFORE YOU BEGIN (WINDOWS® 95 USERS)

Determining Available Resources

Your U.S. Robotics® Voice modem is a Plug and Play device. Windows® 95 can automatically identify a Plug and Play device and determine if your system has the resources necessary to support the device. However, Plug and Play will not work if you do not have resources available or if devices on your system are not reporting resource usage correctly. Here's how you can verify that your system has the necessary resources before installing the modem:

1. Click the Windows 95 **Start** button, point to **Settings**, and then click **Control Panel**.
2. Double-click the **System** icon.

3. When the "System Properties" screen appears, click the **Device Manager** tab.
4. Double-click **Computer** and the "Computer Properties" screen appears.
5. Select the option at the top of the screen to show Interrupt Requests (IRQs).

You will see the IRQs your system is currently using. If IRQs 3, 4, 5, and 7 are being used, you need to free an IRQ before you begin installation. This process involves moving a device from the IRQ you want to use to a different (and usually higher) IRQ setting. Please read the documentation for (or contact the manufacturer of) the device that is currently using the IRQ you want to use for your modem to learn more about how to free the IRQ for your modem.

BEFORE YOU BEGIN (WINDOWS 95 USERS)

Determining Your Version of Windows 95

Follow these steps to determine your version of Windows 95. This information will be important during installation.

1. Click the **My Computer** icon on your desktop with the right mouse button.
2. Click **Properties**.
3. In the “System Properties” screen, look at the system information under the **General** tab (circled in the following screen image). The number following the text “Microsoft Windows 95” will end with “950”, “950a”, or “950b”. This indicates your version of Windows 95. Write this number on the blank below for later reference. Then click **OK**.

Windows 95 version _____

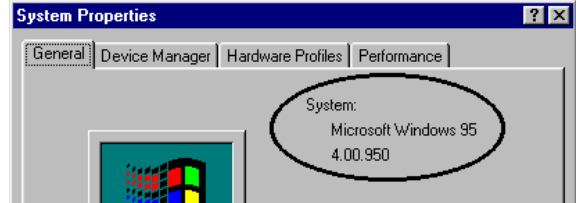

INTERNAL MODEM INSTALLATION WITH WINDOWS[®]

3.x

You will need these items from your U.S. Robotics[®] modem box:

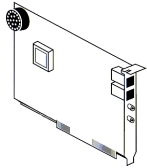

modem



phone cord



Connections[™] CD



microphone

Plus:



screwdriver (not included)

A Word about COM Ports and IRQs

Most computer accessories — mouse, sound card, enhanced graphics card, scanner, etc. — require a special connection through which they can communicate with the computer. For some devices, this connection is called a communications (or COM) port. Most computers have 1 or 2 COM ports, though they can have up to 4. Although internal modems do not connect to COM ports directly, they do require a COM port setting, which is determined by the setting on the modem's COM jumper pins.

INTERNAL MODEM INSTALLATION WITH WINDOWS 3.X

Each COM port uses an interrupt request (IRQ). An accessory uses an IRQ to get the attention of your computer's central processing unit (CPU) so that the accessory can perform a task. The computer stops what it's doing, depending on the priority of the request, to help the accessory perform its task. When two accessories share an IRQ, it's like two people asking different questions in unison to a third person. Just as the person being asked the two questions cannot understand either request, a computer can lock up or otherwise fail to communicate properly with your modem when there is an IRQ conflict.

KEY POINT: Accessories cannot share COM ports and should not share IRQs. When accessories try to share settings, they will either not work properly or not work at all.

3Com has set your modem to a default Plug and Play setting which is ideal for Windows 95 users. In this configuration, the shunts used to set your modem's COM port and IRQ settings are hanging from single jumper pins and will not affect your modem's settings. As a Windows 3.x user, you need to run the ComTest program (on the *Connections*[™] CD) to determine what settings your modem should use.

INTERNAL MODEM INSTALLATION WITH WINDOWS 3.X



NOTE: Some communications software programs require a particular setting for your modem (the RapidComm™ software, which shipped with your modem, does not). If you wish to use a program other than RapidComm, now is a good time to read that software's manual to determine what setting is required.

How to Use ComTest to Determine Your Modem's Settings

1. Insert the *Connections* CD into your CD-ROM drive.
2. In Windows' Program Manager, click **File** and then click **Run**. Type **d:\comtest.exe** and press **ENTER**. This starts ComTest, the program that determines which COM ports and IRQs are available for use by your modem.

3. The screen in the next column appears when ComTest starts.

- If there is a modem in your computer which you are replacing with your new U.S. Robotics modem, go to “Testing an Installed Modem” on [page 9](#) to determine which COM and IRQ settings the older modem is using.
- If a modem is not currently installed in your computer, click **Recommend settings for a new modem**. Then click **Next**.

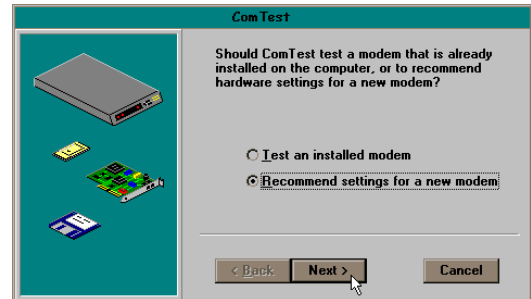

INTERNAL MODEM INSTALLATION WITH WINDOWS 3.X

4. Click **Internal Modem**. Then click **Next**.

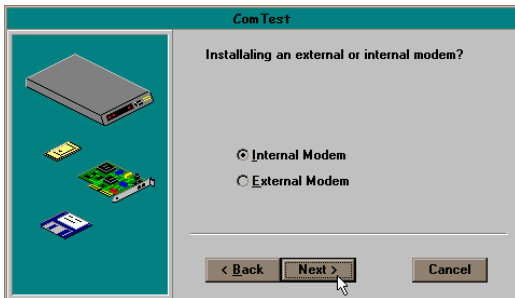

5. If you have a free setting, you will see a screen like this.

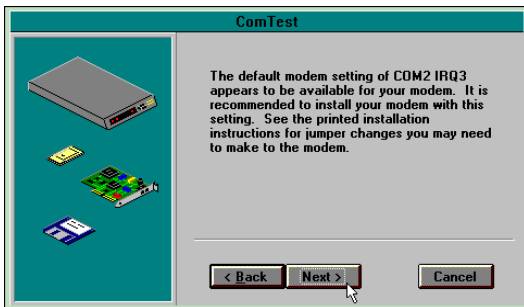

(COM2/IRQ3 is free in this example.)

Write down the displayed settings here:

COM Port _____ IRQ _____

You will need to know these settings later. Click **Next**.

If you do not have a free setting, you will see a screen like the following. Click **Finish** to exit ComTest. Go to “What to Do with ComTest’s Recommendation” on [page 10](#).

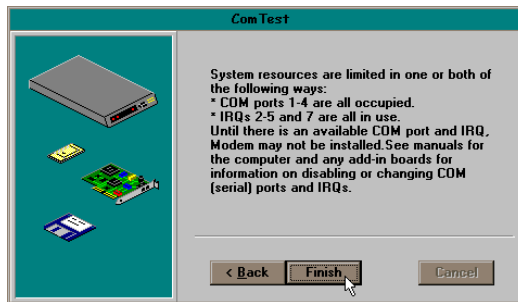

INTERNAL MODEM INSTALLATION WITH WINDOWS 3.X

6. When you see this screen, click **Finish** to exit ComTest.



If ComTest recommended COM 1/IRQ 4 or COM 2/IRQ 3, turn to “How to Change the Modem’s Settings” on [page 12](#). Otherwise, go to “What to Do with ComTest’s Recommendation” on [page 10](#).

Testing an Installed Modem

If there is a modem already installed in your computer, you can determine its COM and IRQ settings by selecting the **Test an installed modem** option. Follow the instructions on screen until you see the screen that tells you “Testing is complete.” This screen will also tell you which COM and IRQ settings your present modem is using. These are the settings you want to use for your new U.S. Robotics modem. Write down the displayed settings here:

COM Port _____ IRQ _____

Turn off and unplug your computer and remove your present modem using its documentation as a guide. Go to “How to Change the Modem’s Settings” on [page 12](#).

What to Do with ComTest's Recommendation



NOTE: If your communications software requires a modem setting that ComTest does not recommend, there is a good chance that the setting is being used by another device in your system. To free that setting in your system, consult your computer's manual. Go to "How to Change the Modem's Settings" on [page 12](#).

If ComTest recommended COM3/IRQ4 or COM4/IRQ3

Do not use either of these settings. While the COM port part of the setting is acceptable (ComTest only recommends COM ports that are not being used), the IRQ part of the setting

is not acceptable. When ComTest recommends either COM3/IRQ4 or COM4/IRQ3, the IRQ in the setting is being used by another accessory. You could use the suggested IRQ for the modem, but you run the risk that the modem and/or the other accessory sharing the IRQ might not work properly.

If you do not have a sound card, use COM3/IRQ5. Write "COM3" and "IRQ5" where it will be convenient during the software installation. You will have to change the settings on your modem. Go to "How to Change the Modem's Settings" on [page 12](#).

If you do have a sound card, use COM2/IRQ3. To use this setting, you have to first disable your computer's second serial port (COM2). This is a pronged socket on the back of your computer.

- Go to your computer manufacturer's manual.

INTERNAL MODEM INSTALLATION WITH WINDOWS 3.X

- Find out how to disable the COM port.
- Find out which of the sockets on the back of your computer COM 2.
- If you have something plugged into that port, find out if you can plug it in somewhere else. Any accessory plugged into that port will not work after the port has been disabled.
- Then return to this point in this manual to continue.

After disabling COM2, you can use the COM2/IRQ3 setting.

Write “COM2” and “IRQ3” where it will be convenient during the software installation and go to “How to Change the Modem’s Settings” on [page 12](#).

If ComTest reports that “You do not have any available COM ports and/or IRQs”

We recommend you disable COM1 or COM2. When you disable one of these COM ports, you can use it and its default IRQ for your modem. Go to your computer manufacturer’s manual.

- Find out which socket is COM1 and which is COM2.
- If nothing is plugged into either port, you may choose either of the ports to disable. Your computer manufacturer’s manual will tell you how to disable the COM port.
- If one port does not have anything plugged into it, note if the port is COM1 or COM2. This is the port you’ll want to disable for your modem.
- If both ports are being used, you may be able to attach one of the plugged-in

INTERNAL MODEM INSTALLATION WITH WINDOWS 3.X

accessories elsewhere so that you can disable its COM port. The accessory will not work once its port is disabled.

If you've disabled COM1, you can now use the COM1/IRQ4 setting. Write this setting down where it will be convenient during the software installation.

If you've disabled COM2, you can now use the COM2/IRQ3 setting. Write the setting down where it will be convenient during the software installation. Go to "How to Change the Modem's Settings" (on this page).

How to Change the Modem's Settings

1. Always touch an unpainted metal part of your computer (the back is usually unpainted) to discharge static electricity before handling the modem. Static can

damage your modem. Then take the modem out of its plastic bag.

2. Find the COM and IRQ jumper shunts (small black plastic pieces) on your modem's jumper pins (see the following diagram).

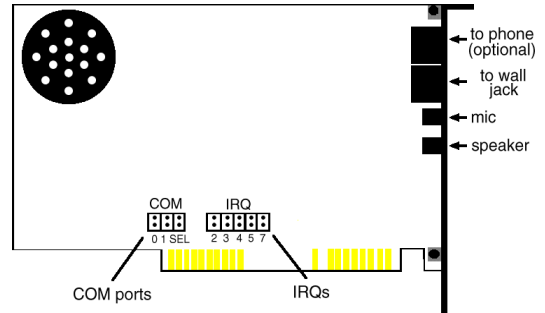

3. To change the COM port and IRQ settings, you need to reposition the jumper shunts on the COM port and IRQ pins. To do this, lift the jumper shunts off the pins.

INTERNAL MODEM INSTALLATION WITH WINDOWS 3.X



TIP: Grasp the jumper shunts with a tweezers or needle-nosed pliers. DO NOT grasp too firmly, as you may crush the jumper shunts. If a jumper shunt seems stuck, gently rock it back and forth as you lift. Do not touch any other part of the modem or your computer with the tweezers/pliers. A jumper shunt needs to be sitting on both jumper pins in order to effectively set the modem to the desired setting.

4. Move the jumper shunt to the new setting.
 - The COM port setting can involve one to three shunts. The four possible COM port settings are as follows:

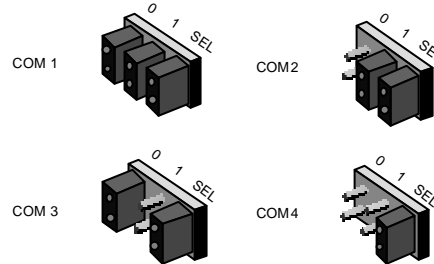

- Unlike most COM port settings, the IRQ setting involves only one jumper shunt. Simply move the jumper shunt to the pins labeled with the IRQ you need.

How to Insert the Modem into the Computer



NOTE: Before installing your modem, write its serial number in the space provided here:

**SERIAL
NUMBER:** _____

You will find the serial number underneath the bar code on the white sticker on the modem and on the outside of the box the modem came in. If you ever need to call our customer support department, a customer support representative will ask you for the serial number. This will help him or her identify your modem.

1. Turn off your computer and unplug it from the electrical outlet.
2. Unplug any peripheral devices (printer, monitor, keyboard, mouse, etc.) from the computer.



TIP: Before you unplug anything, label the cords or make a sketch of how things are connected. This can be helpful when you plug things back in later.



CAUTION: To avoid the risk of electric shock, make sure your computer and all peripheral devices are turned off and unplugged.

INTERNAL MODEM INSTALLATION WITH WINDOWS 3.X

3. Remove the screws from your computer's cover and then remove the cover, as shown in the following diagrams. Your computer may differ in appearance from these diagrams, but the basic principle for removing the cover should be the same. Contact your computer manufacturer or review their manual if you need further instructions.

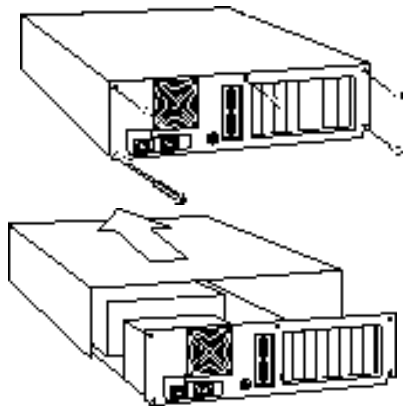

4. Find an empty ISA expansion slot at least as long as the gold edge of your modem. (ISA slots are usually black plastic grooves lined with silver metal.) Unscrew and remove the expansion slot cover (the long narrow piece of metal that keeps dust from entering through the opening perpendicular to the slot). Be careful not to drop the screw into the computer. You will need it later to screw the modem into place.

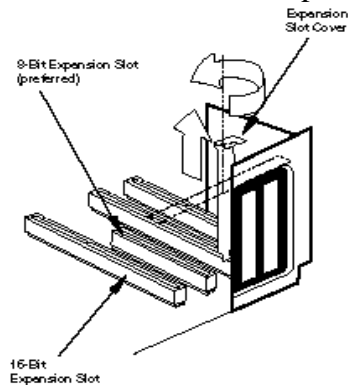

INTERNAL MODEM INSTALLATION WITH WINDOWS 3.X

5. Holding the modem at each corner, with the gold edge facing the slot, push the modem down as gently as possible until it snaps into the expansion slot. (The drawings show horizontally aligned expansion slots. Some computers have vertically aligned slots. The instructions apply to both styles.)

You need to apply a little pressure to seat the modem properly. Sometimes a gentle back-and-forth motion helps to fit the modem all the way into the slot. If you feel resistance, the modem may not be properly lined up with the slot. Do not force it into the slot. Remove the modem and try again.

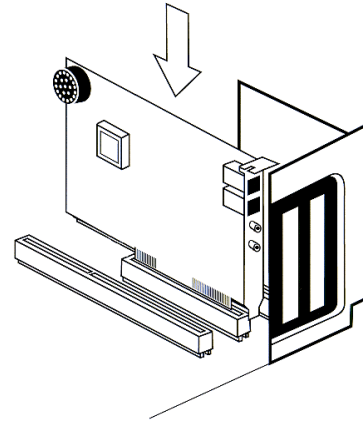

6. Once the modem is in the slot, fasten it firmly into place using the screw that you removed in step 4.
7. Replace the computer's cover and fasten it with the screws you removed in step 3.
8. If you currently have a phone plugged into the wall jack you plan to use for the modem, disconnect the phone's cord from the jack.

INTERNAL MODEM INSTALLATION WITH WINDOWS 3.X



WARNING : The phone jack you use must be for an ANALOG phone line (the type found in most homes). Many office buildings have digital phone lines. Be sure you know which type of line you have. The modem will be damaged if you use a digital phone line.

9. Plug one end of the phone cord that came with the modem into the TELCO jack at the rear of the modem. Plug the other end of the cord into the wall jack.
10. If you wish to use a phone through the line the modem uses (when the modem is not in use), plug your phone's cord into the modem's PHONE jack.

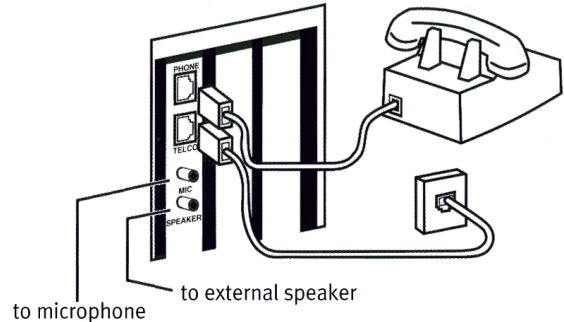

NOTE: You cannot use the modem and a phone at the same time if they share the same telephone line.

11. Plug the microphone into the MIC jack on the modem.
12. To use the modem's full-duplex speakerphone capabilities, plug a set of powered external speakers (not included) into the SPEAKER jack on the modem.

INTERNAL MODEM INSTALLATION WITH WINDOWS 3.X

13. Plug the power cords, cables, and peripherals back into the computer and turn the computer on.

14. Start Windows.

15. If you have your modem set to COM1/IRQ4 or COM2/IRQ3, go to “Software Installation” on [page 47](#). If you have your modem configured to any other setting, open Program Manager and double-click the **Main** icon.

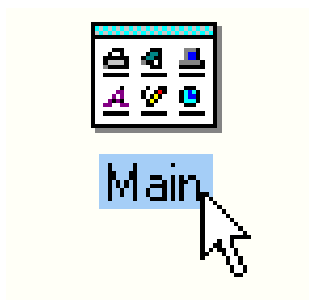

16. Double-click the **Control Panel** icon.

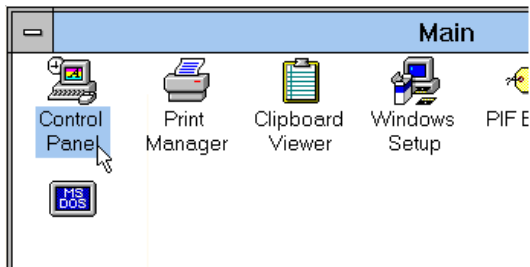

17. Double-click the **Ports** icon.

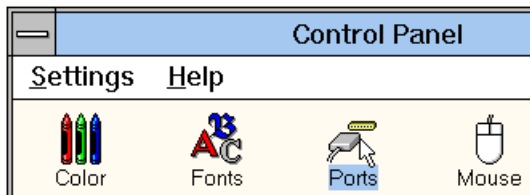

INTERNAL MODEM INSTALLATION WITH WINDOWS 3.X

18. If it's not already selected, click the COM port for your modem. Then click **Settings**.

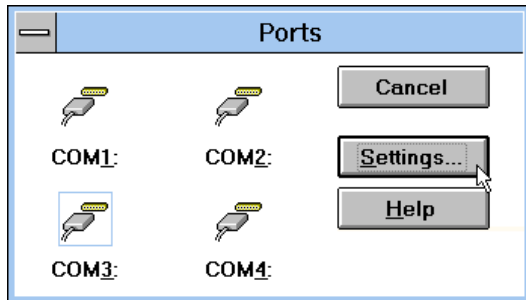

19. Click **Advanced**.

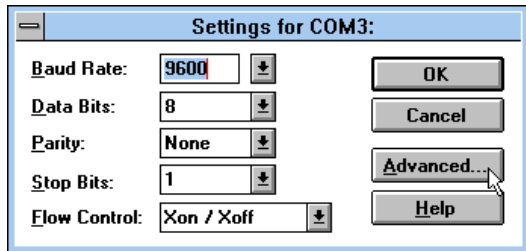

20. In the **Interrupt Request Line (IRQ)** box, select the IRQ that ComTest recommended.

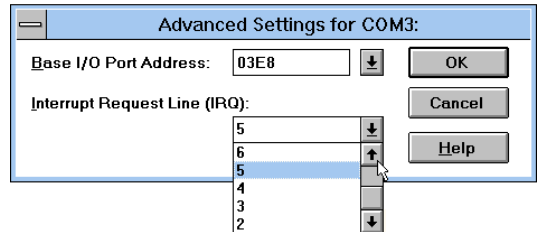

21. Click **OK**.

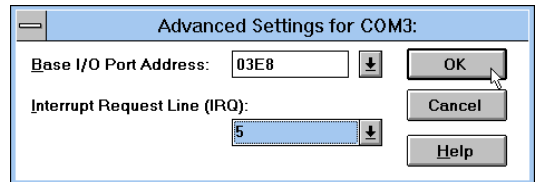

22. You will see a screen prompting you to restart Windows. Click **Restart Now**.

INTERNAL MODEM INSTALLATION WITH WINDOWS 3.X

When Windows restarts, you are ready to install the *Connections* program group and

register your modem online. Turn to “Software Installation” ([page 47](#)) for more information.

INTERNAL MODEM INSTALLATION WITH WINDOWS[®] 95

You will need these items from your U.S. Robotics[®] modem box:

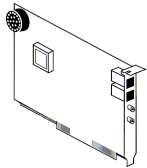

modem



phone cord



Connections[™] CD



microphone

Plus:



screwdriver (not included)



NOTE: Complete the instructions in the section “Before You Begin (Windows 95 Users)” on [page 3](#) before continuing with the following instructions.

Your new U.S. Robotics modem is a “Plug and Play” device. This means Windows 95 should be able to detect your modem automatically after you plug it into your computer. The next section covers preparing your new modem for Plug and Play installation.

How to Prepare for Plug and Play Installation

1. Touch an unpainted metal part of your computer (the back is usually unpainted) to discharge static electricity. Static can damage your modem.
2. Take the modem out of its plastic bag.
3. Find the jumper shunts (small black plastic pieces) on the COM port and IRQ jumper pins on your modem. They should be in roughly the area indicated in the following illustration.

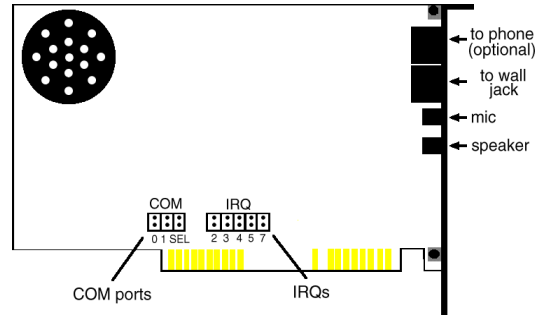

When doing a “Plug and Play” installation, the jumper shunts should be placed so that they are hanging from single jumper pins rather than on pairs of pins. Move your jumper shunts so they are hanging as in the following diagram.

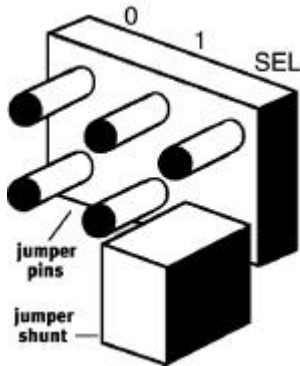

How to Insert the Modem into the Computer



NOTE: Before installing your modem, write its serial number here:

SERIAL NUMBER _____

You'll find the serial number underneath the bar code on the white sticker on the modem and on the outside of the box the modem came in. If you call our customer support department, a customer support representative will ask you for the serial number. This will help him or her identify your modem.



NOTE: If you need to move the jumper shunts, grasp them with a tweezers or a needle-nosed pliers. **DO NOT** grasp too firmly, however, or you may crush the jumper shunts. If a jumper shunt seems stuck, try gently rocking it back and forth as you lift.

INTERNAL MODEM INSTALLATION WITH WINDOWS 95

1. Turn off your computer and unplug it from the electrical outlet.
2. Unplug any peripheral devices (printer, monitor, keyboard, mouse, etc.) from the computer.



TIP : Before you unplug any cords, label them or make a sketch of how they are connected. This can be helpful when you plug them back in later.



CAUTION : To avoid risk of electric shock, make sure your computer and all peripheral devices are turned off and unplugged from electrical outlets.

3. Remove the screws from your computer's cover and then remove the cover, as shown

in the following diagrams. Your computer may differ in appearance from these diagrams, but the basic principle for removing the cover should be the same. Refer to your computer manufacturer's manual if you need further instructions.

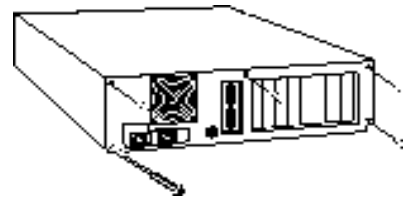

INTERNAL MODEM INSTALLATION WITH WINDOWS 95

4. Find an empty ISA expansion slot that's at least as long as the gold edge of your modem. (ISA slots are usually black plastic grooves lined with silver metal.) Unscrew and remove the expansion slot cover (the long narrow piece of metal that keeps dust from entering through the opening perpendicular to the slot). Be careful not to drop the screw into the computer. You will need it later to screw the modem into place.

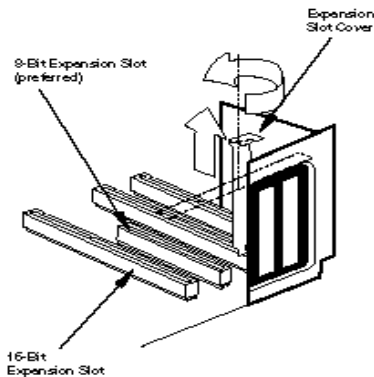

5. Holding the modem at each corner, with the gold edge facing the slot, push the modem down as gently as possible until it snaps into the expansion slot. (The following diagram shows horizontally aligned expansion slots. Some computers have vertically aligned slots. The instructions apply to both styles.)

You need to apply a little pressure to seat the modem properly. Sometimes a gentle back-and-forth motion helps fit the modem all the way into the slot. If you feel resistance, the modem may not be properly lined up with the slot. Do not force it into the slot. Remove the modem and try again.

INTERNAL MODEM INSTALLATION WITH WINDOWS 95

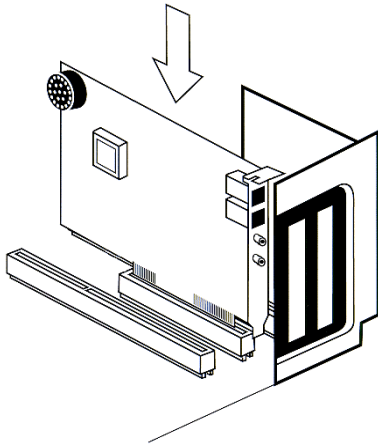

6. Once the modem is in the slot, fasten it firmly into place using the screw that you removed in step 4.
7. Replace the computer's cover and fasten it with the screws you removed in step 3.
8. Locate the wall jack you plan to use for the modem. If you have a phone plugged into

this jack, disconnect the telephone cord from the jack.



WARNING : The phone jack you use must be for an **ANALOG** phone line (the type found in most homes). Many office buildings have **digital** phone lines. Be sure you know which type of line you have. The modem will be damaged if you use a **digital** phone line.

9. Plug one end of the phone cord included with the modem into the TELCO jack at the rear of the modem. Plug the other end of the cable into the wall jack.
10. If you wish to use a phone on the line the modem is using when the modem is not in use, plug your phone's cord into the modem's PHONE jack.



NOTE: You cannot use the modem and a phone at the same time if they share the same telephone line.

11. Plug the microphone into the MIC jack on the modem.
12. To use the modem's full-duplex speakerphone capabilities, plug a set of powered external speakers (not included) into the SPEAKER jack on the modem.

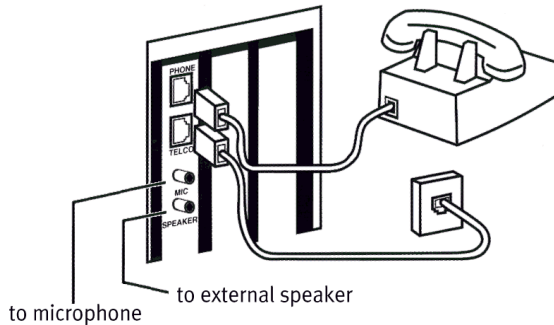

13. Plug the power cords, cables, and peripherals back into the computer and turn on the computer.

Installing the Modem Drivers



NOTE: If you wrote "950b" on [page 4](#) of this User's Guide, go to "Installing Modem Drivers with Windows 95 Version 950b" on [page 31](#). Otherwise, follow these instructions.

Installing Modem Drivers with Windows 95 Versions 950 and 950a

1. When Windows 95 restarts, it should detect the modem. If it does, you will see the following screen.

INTERNAL MODEM INSTALLATION WITH WINDOWS 95



Click **Driver from disk provided by hardware manufacturer**. Then click **OK**.



NOTE: If this screen does not appear, go to the section titled "If Plug and Play Does Not Detect Your Modem" on [page 83](#).

2. When you see this screen, insert the *Connections* CD into your CD-ROM drive and type **D:** to replace the **A:**. (If your CD-ROM drive has a different letter name, type that letter instead of **D**.)

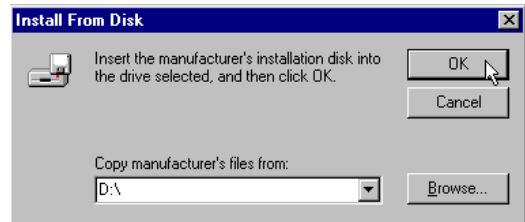

Click **OK**. Windows will load the modem's drivers.

INTERNAL MODEM INSTALLATION WITH WINDOWS 95

3. Once Windows finishes loading the information from the CD-ROM, you should verify that the modem installation was a success. When your desktop returns, click the Windows **Start** button and point to **Settings**. Then click **Control Panel**.

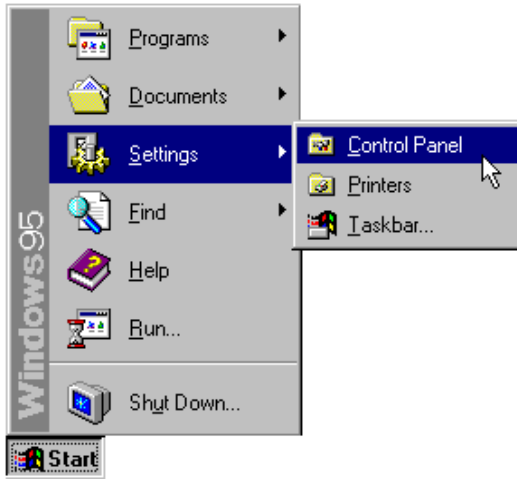

4. Double-click the **Modems** icon (circled in the screen image below).

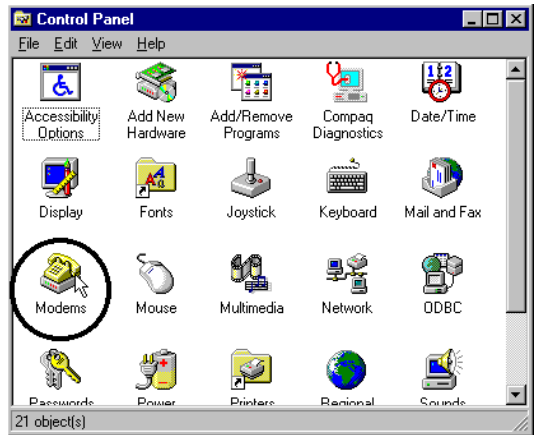

5. In the “Modems Properties” screen, you should see a description of your modem.

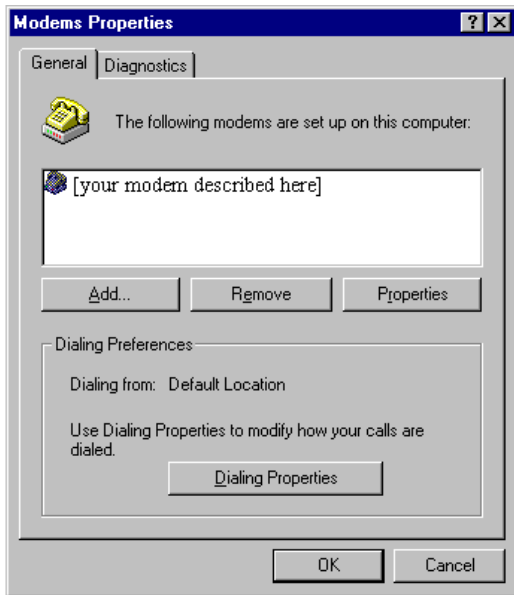

This means the installation was a success. Click **OK**.

 **NOTE:** If you do not see your modem listed in the preceding screen, the Plug and Play installation was unsuccessful. Please refer to the “If Plug and Play Does Not Detect Your Modem” section on [page 83](#).

6. Next, click the **Diagnostics** tab at the top of the “Modems Properties” screen. Write down the COM setting for your modem below. (Your screen may show a different setting than that shown in the following screen.) You will need to know this setting when you install fax/data communications software. Click **OK**.

COM Port _____

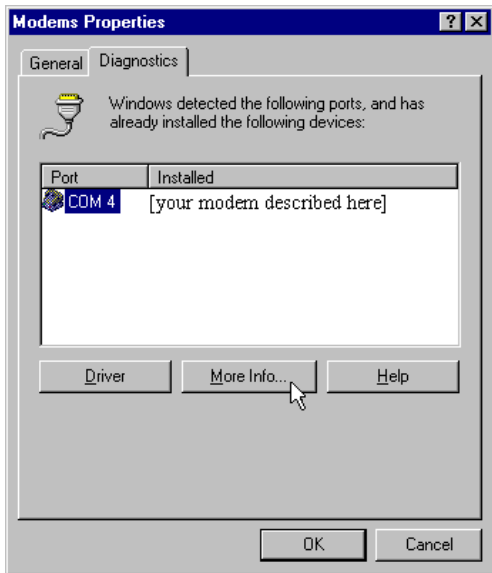

You are now ready to install the *Connections* program group and register your modem online. Turn to “Software Installation” (page 47) for more information.

Installing Modem Drivers with Windows 95 Version 950b

1. When Windows restarts, it should detect the modem (see screen below). Insert the *Connections* CD and click **Next**.

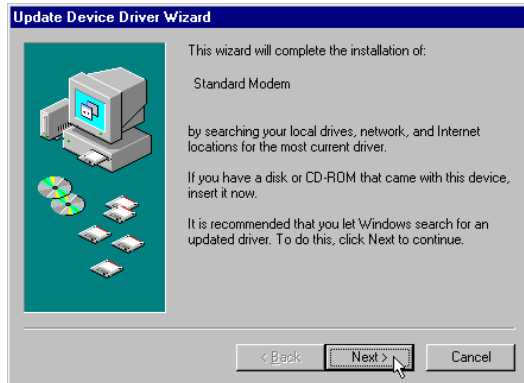



NOTE: If this screen does not appear, go to “If Plug and Play Does Not Detect Your Modem” on [page 83](#).

2. When you see the following screen, click **Finish**.



3. Now you should verify that the modem installation was a success. When your desktop returns, click the Windows **Start** button and point to **Settings**. Then click **Control Panel**.

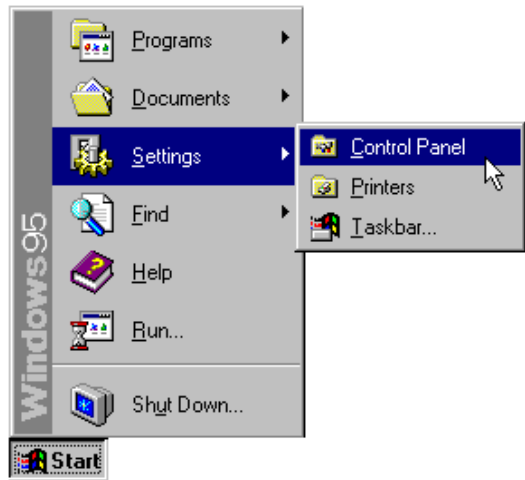

INTERNAL MODEM INSTALLATION WITH WINDOWS 95

4. Double-click the **Modems** icon (circled in the screen image below).

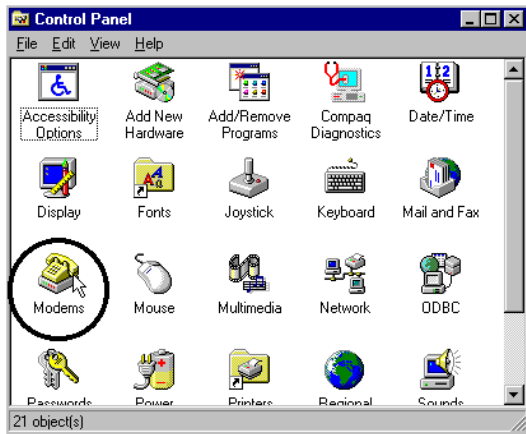

5. In the “Modems Properties” screen, you should see a description of your modem.

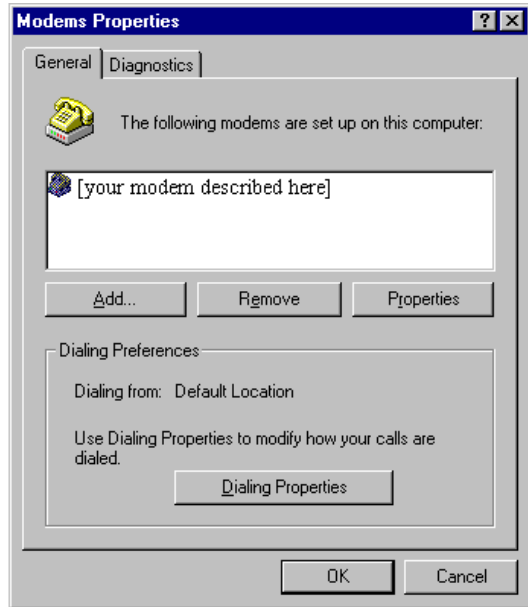

This means the installation was a success. Click **OK**.



NOTE: If you do not see your modem listed in the preceding screen, the Plug and Play installation was unsuccessful. Please refer to the “If Plug and Play Does Not Detect Your Modem” section on [page 83](#).

6. Next, click the **Diagnostics** tab at the top of the “Modems Properties” screen. Write down the COM setting for your modem below. (Your screen may show a different setting than that shown in the following screen.) You will need to know this setting when you install fax/data communications software. Click **OK**.

COM Port _____

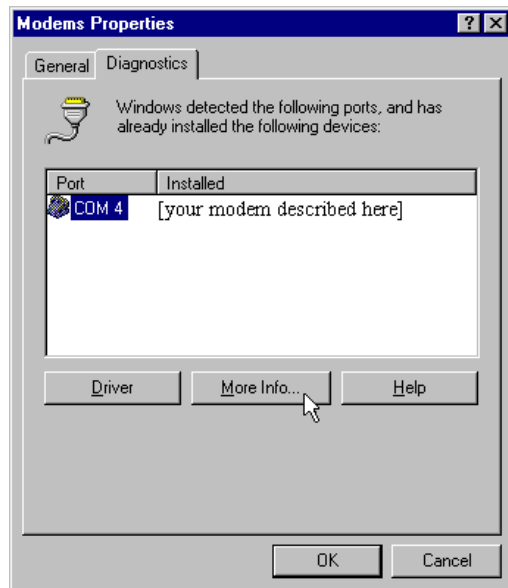

You are now ready to install the *Connections* program group and register your modem online. Turn to “Software Installation” ([page 47](#)) for more information.

EXTERNAL MODEM INSTALLATION WITH WINDOWS 95

You'll need these items from your U.S. Robotics® box:



modem



phone cord



Connections[®] CD



power adapter

Plus:

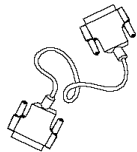

RS-232 serial modem cable (NOT a “null-modem” cable). (The cable is not included. See next column for more details.)



NOTE: Complete the instructions in the section “Before You Begin (Windows 95 Users)” on [page 3](#) before continuing with the following instructions.

Determining Which Serial Cable to Buy

Before you can begin installation, you need to purchase an RS-232 serial modem cable (NOT a “null-modem” cable). This section will help you to determine which serial modem cable to purchase.



NOTE: Your computer's rear panel may not be identical to the following diagrams. However, you should look for connectors that match the enlarged portions of the diagrams. If you cannot locate the proper connector, refer to your computer's manual.

If your PC's serial connector looks like this...

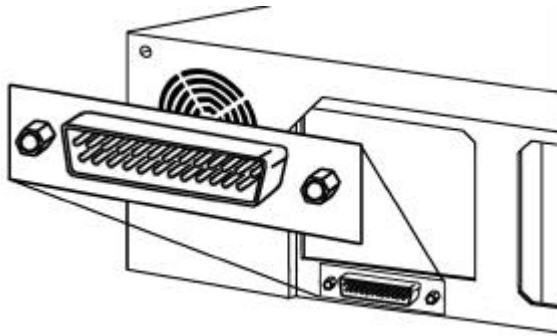

you need a shielded serial modem cable with a 25-pin female to 25-pin male connector.

If your PC's serial connector looks like this...

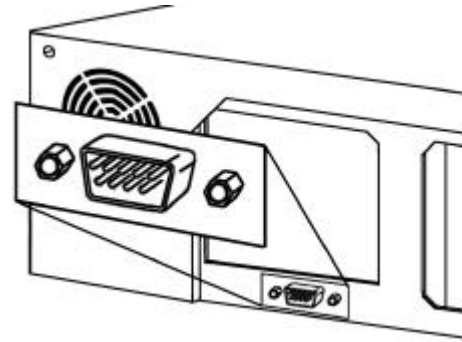

you need a shielded serial modem cable with a 9-pin female to 25-pin male connector.

Connecting the Modem to the Computer

1. Turn off your computer and any attached peripherals.
2. Connect the serial cable to the modem and to the computer. When looking for the serial port on the back of your computer, look for labels marked COM, MODEM, RS-232, or SERIAL.
DO NOT select AUX, GAME, LPT, or PARALLEL.

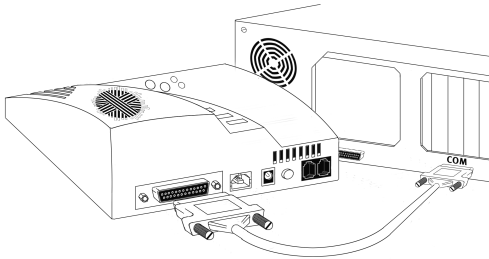

3. Plug one end of the phone cord into the TELCO jack and the other end into a phone wall jack.

 **CAUTION :** The phone jack you use must be for an **ANALOG** phone line (the type found in most homes). Many office buildings have digital phone lines. Be sure you know which type of line you have. The modem will be damaged if you use a digital phone line.

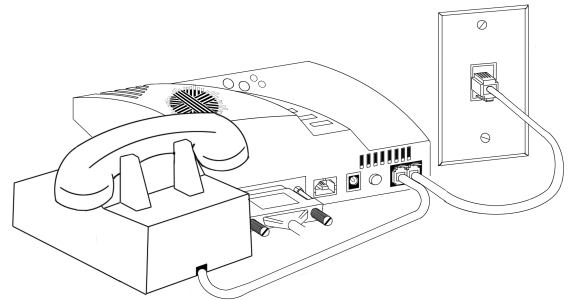

EXTERNAL MODEM INSTALLATION WITH WINDOWS 95

If you wish to use your modem and phone through the same phone wall jack, plug your phone's cord into the modem's PHONE jack.



NOTE: You cannot use the modem and phone at the same time if they share the same telephone line.

4. Plug the power adapter that came with the modem into a standard, 110-volt wall outlet and insert its plug into the power jack on the modem.



NOTE: If you use a different power adapter or plug the adapter into a higher-voltage outlet, you may damage the modem.

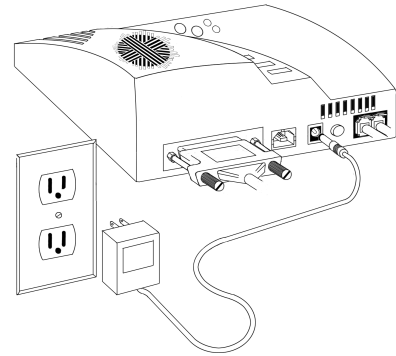

5. Turn on your modem. (The power switch is next to the modem's phone cord jacks.)

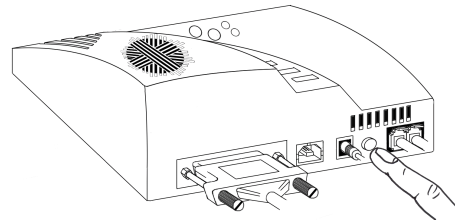

6. Turn on your computer and peripherals.

Installing the Modem Drivers



NOTE: If you wrote “950b” on [page 4](#) of this User’s Guide, go to “Installing Modem Drivers with Windows 95 Version 950b” on [page 43](#). If you wrote “950” or “950a,” follow the instructions that begin below.

Installing Modem Drivers with Windows 95 Versions 950 and 950a

1. When Windows 95 restarts, it should detect the modem. If it does, you will see the following screen.

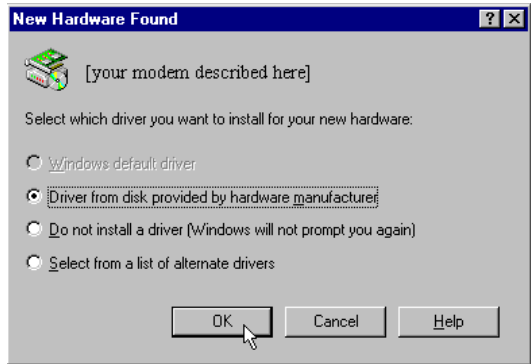

Click **Driver from disk provided by hardware manufacturer**. Then click **OK**.



NOTE: If this screen does not appear, go to the section titled “If Plug and Play Does Not Detect Your Modem” on [page 83](#).

EXTERNAL MODEM INSTALLATION WITH WINDOWS 95

2. When you see this screen, insert the *Connections* CD into your CD-ROM drive and type **D:** to replace the **A:**. (If your CD-ROM drive has a different letter name, type that letter instead of **D**.)

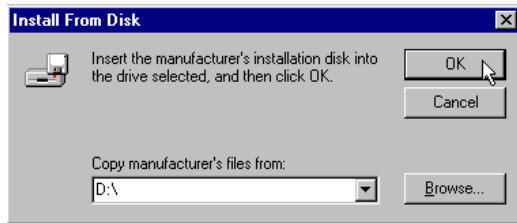

Click **OK**. Windows will load the modem's drivers.

3. Once Windows finishes loading the information from the CD-ROM, you should verify that the modem installation was a success. When your desktop returns, click the Windows **Start** button and point to **Settings**. Then click **Control Panel**.

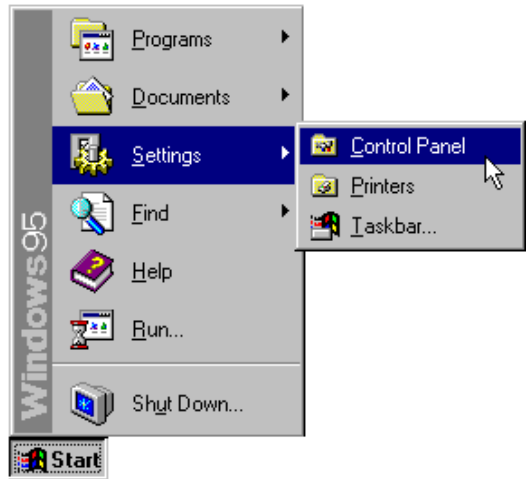

EXTERNAL MODEM INSTALLATION WITH WINDOWS 95

4. Double-click the **Modems** icon (circled in the screen image below).

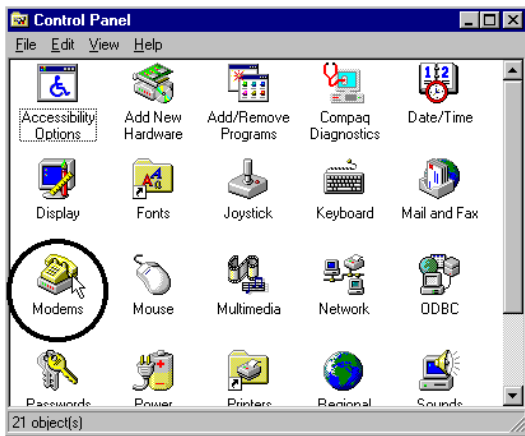

5. In the “Modems Properties” screen, you should see your modem listed.

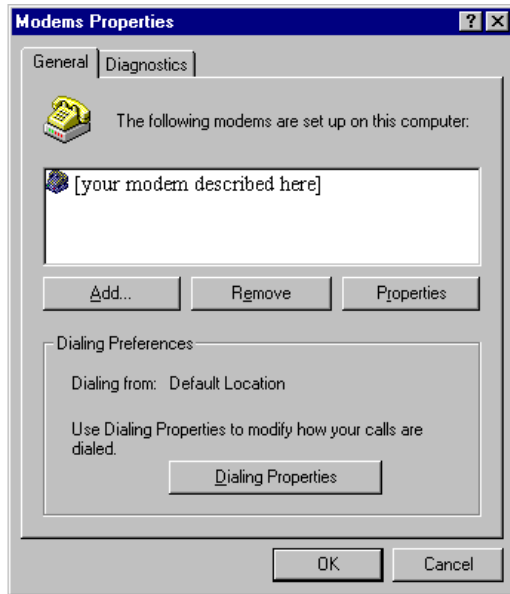

This means the installation was a success.

EXTERNAL MODEM INSTALLATION WITH WINDOWS 95

- Next, click the **Diagnostics** tab at the top of the “Modems Properties” screen. Write down the COM setting for your modem below. (Your screen may show a different setting than that shown in the following screen.) You will need to know this setting when you install fax/data communications software. Click **OK**.

COM Port _____

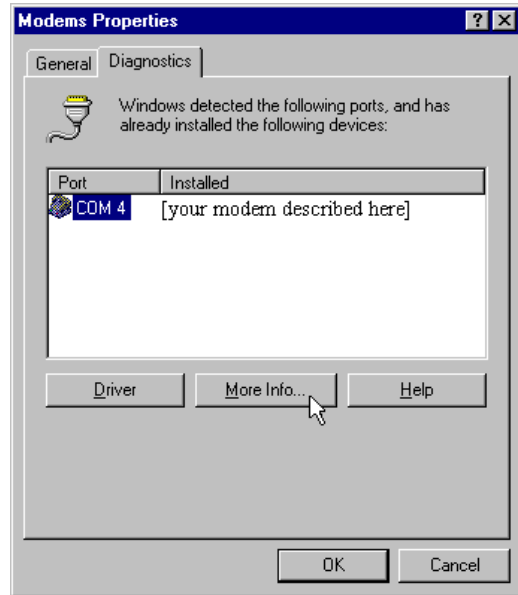

You are now ready to install the *Connections* program group and register your modem online. Turn to “Software Installation” ([page 47](#)) for more information.

Installing Modem Drivers with Windows 95 Version 950b

1. When Windows restarts, it should detect the modem. Insert the *Connections* CD and click **Next**.

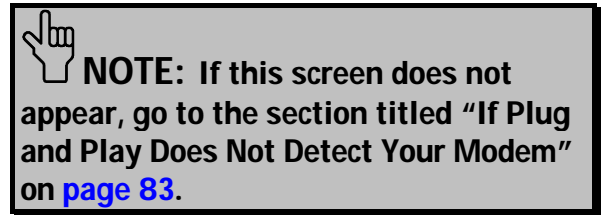

2. When you see the following screen, click **Finish**.

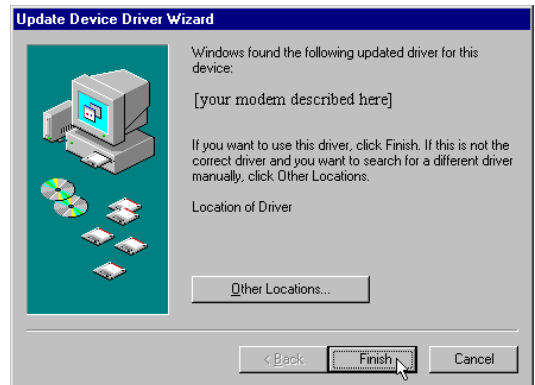

EXTERNAL MODEM INSTALLATION WITH WINDOWS 95

3. Now you should verify that the modem installation was a success. When your desktop returns, click the Windows **Start** button and point to **Settings**. Then click **Control Panel**.

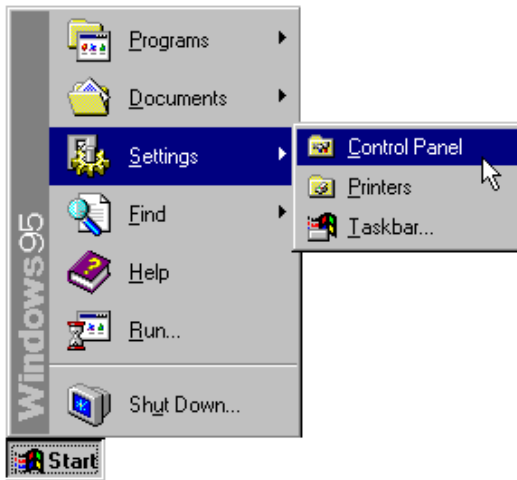

4. Double-click the **Modems** icon (circled in the screen image below).

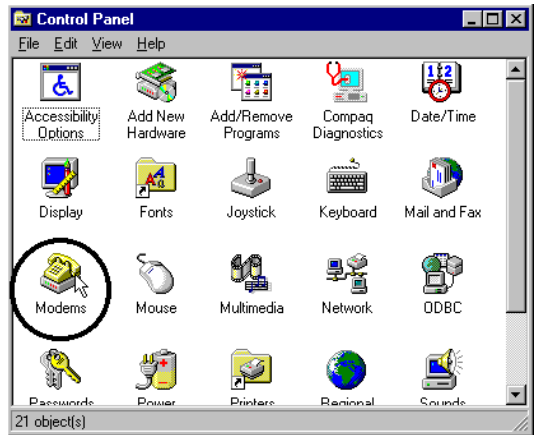

5. In the “Modems Properties” screen, you should see your modem listed.

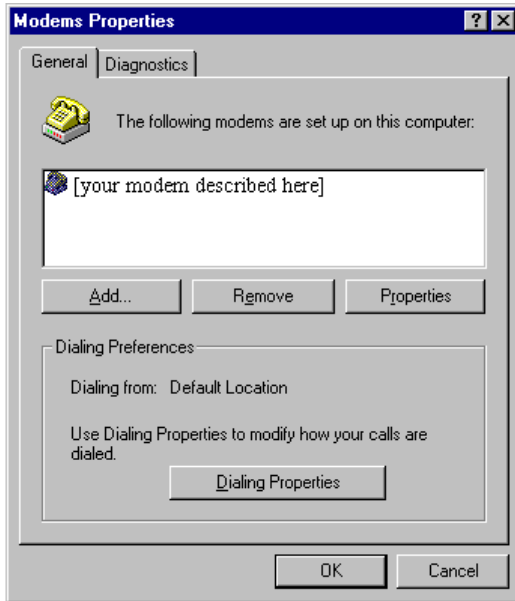

This means the installation was a success.



NOTE: If you do not see your modem listed in the preceding screen, the Plug and Play installation was unsuccessful. Please refer to the “If Plug and Play Does Not Detect Your Modem” section on [page 83](#).

6. Next, click the **Diagnostics** tab at the top of the “Modems Properties” screen. Write down the COM setting for your modem below. (Your screen may show a different setting than that shown in the following screen.) You will need to know this setting when you install your communications software. Click **OK**.

COM Port _____

EXTERNAL MODEM INSTALLATION WITH WINDOWS 95

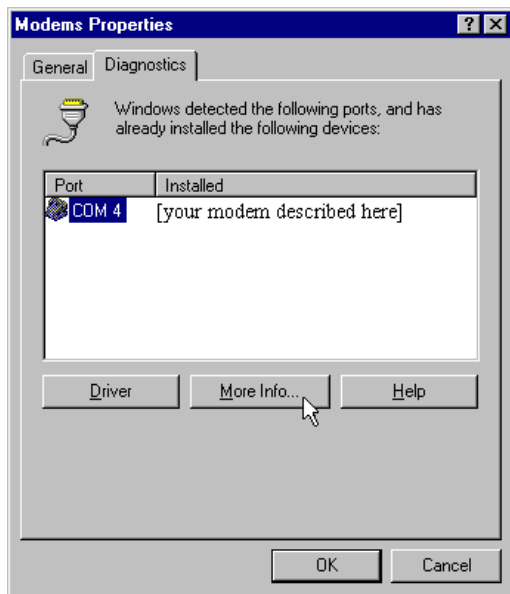

You are now ready to install the *Connections* program group and register your modem online. Turn to “Software Installation” ([page 47](#)) for more information.

SOFTWARE INSTALLATION

This section explains running the U.S. Robotics Setup Wizard on the *Connections*[™] CD.

The Wizard will guide you through installing the Connections program group and testing your modem by registering online.

Follow this section's instructions to start the Wizard and then follow the Wizard's on-screen instructions.



NOTE: The following instructions apply to Windows 3.x and Windows 95 users. However, only Windows 95 screens are shown.

Running the Setup Wizard

1. From the Windows 95 desktop, click the **Start** button and then click **Run**.

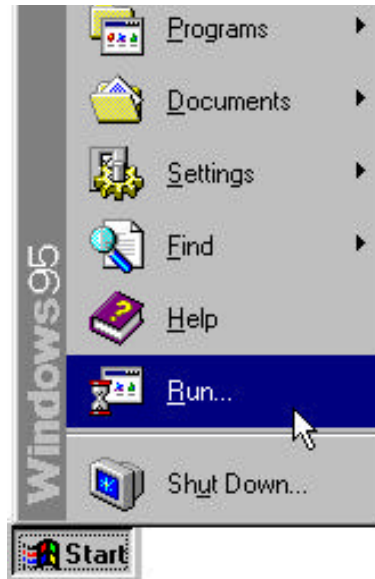

SOFTWARE INSTALLATION

2. In the text box, type **D:\setup.exe**.
(If your CD-ROM drive has a letter name other than **D**, type that letter in place of **D**.)
Then click **OK**.

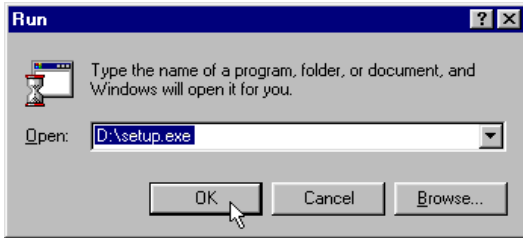

3. Follow the on-screen instructions. After running the Setup Wizard, you will be given the option to explore the *Connections* CD.

Using *Connections* Software

Once installation is complete, you can use the *Connections* CD at any time by following these steps:

1. Insert the *Connections* CD into your CD-ROM drive.
2. Click **Start**, point to **Programs**, point to **U.S. Robotics Connections**, and then click **Connections**.

Installing the RapidComm™ Voice Fax/Data/Voice Software



NOTE: If you have an older version of RapidComm Voice installed on your system, uninstall it before continuing. To start the uninstall:
Windows 3.x users: Click on the Uninstall icon in the RapidComm Voice program group. Windows 95 users: Double-click on the Add/Remove Programs icon in the Control Panel.

SOFTWARE INSTALLATION

The *Connections* CD contains the RapidComm Voice fax/data/voice communications program. You can use this software to transfer faxes and data files to remote modems and manage your voice mail.

Once you have installed the Connections program group, you can install RapidComm Voice. (The Setup Wizard does not install RapidComm Voice.)

Follow these instructions to install RapidComm Voice:

1. Start the *Connections* CD (follow the instructions in the section “Using Connections” on [page 48](#)).
2. On the main *Connections* menu, click the **Business & Productivity** button.
3. Click the **RapidComm Voice** button.

4. Follow the on-screen instructions to finish the installation.

The CD also contains an electronic user’s manual for RapidComm Voice.

Congratulations—you are now ready to start using your U.S. Robotics modem!

INSTALLING OTHER FAX/DATA SOFTWARE

You can use fax/data/voice software other than RapidComm Voice (the fax/data/voice software on the *Connections* CD). Your modem was designed for and tested using a wide range of communications software packages. This section will guide you through some of the details you may need to know when installing other communications software packages.

Type of Modem

Most communications software programs will ask you to select the type of modem you are using. Select a *U.S. Robotics Sportster high speed modem*. If that selection is not listed, pick *Courier Dual Standard, V.32bis, or V.34*.

KEY POINT: Refer to your software manual for the program's installation instructions. The software's installation program will ask you questions about the modem you are using.

Initialization String

For hardware flow control, a fixed serial port rate and full result codes, type **AT&F1** and press **ENTER**. If you must use software flow control, type **AT&F2** and press **ENTER**.

 **NOTE:** If you use the Modem Station program to configure your modem, you must use **ATZ** for the initialization string.

Flow Control

- For hardware flow control (highly recommended), select **RTS/CTS**.
- For software flow control, select **XON/XOFF**.

 **NOTE: You may need to disable the type of flow control (hardware or software) that you are not using.**

UART (External Modems)

If you are running Windows 3.x or you have upgraded your system from Windows 3.x to Windows 95, you can run MSD to determine your UART setting. In DOS, type **MSD** at the Windows directory prompt and then press **ENTER**. Follow the on-screen instructions to access the COM port settings panel. In this panel you should find the UART chip used.

Match the UART type listed in MSD with the serial rate listed in the chart below. Select this serial rate (sometimes called the “port rate”) in any communications software you use.

<u>If this is your UART...</u>	<u>Select this serial rate</u>
16550*	115.2 or 57.6 kbps
16450	38.4 kbps
8250	19.2 kbps
*All U.S. Robotics internal modems have a 16550 UART.	

 **NOTE: DO NOT select a 28,800, 14,400, or 12,000 bps serial port rate, if offered. Your modem will NOT work correctly with any of these settings. Fix or lock the serial port (baud) rate (if it's referred to as autobaud, select OFF).**

USING MODEM STATION

What Does Modem Station Do?

- ◆ Modem Station provides a simple to use interface that makes communicating with your modem easy.
- ◆ Modem Station allows you to point and click your way through configuration.
- ◆ Modem Station can automatically detect your modem and provide you with all the technical information you need, whenever you need it!

Why Modem Station?

- ◆ Modem commands can be confusing and difficult to memorize.
- ◆ Communications software often requires technical information about your modem.

- ◆ You may want to “tweak” your modem for optimum performance.

Installing Modem Station

If you did not install Modem Station when you first installed the *Connections* CD, please follow these instructions.

1. Insert the *Connections* CD into your CD-ROM drive.
2. Double-click the **My Computer** icon on your desktop.
3. Double-click the **CD-ROM** icon.
4. Double-click the **usrtools** folder.
5. Double-click the **umssetup** icon.

USING MODEM STATION

6. You will be asked whether you wish to install Modem Station. Click **Yes**.
7. Wait a few moments for the Installation Wizard to load.
8. After reading the information on the “Welcome” screen, click **Next**.



9. When you see this screen, click **Next** to accept the default directory or click **Browse** to change directories.

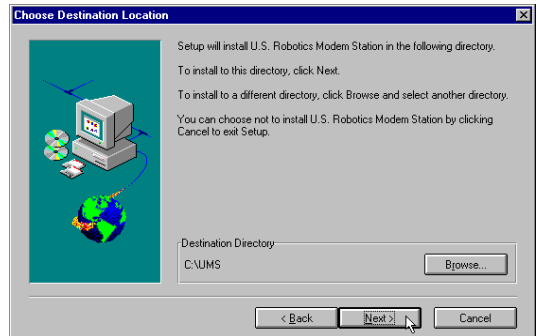

USING MODEM STATION

10. Click **Next** on the following screen to accept the default program folder. You can place Modem Station in an existing folder by selecting one from the list.

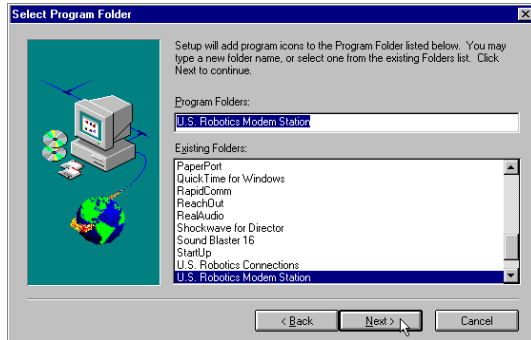

11. When you see the following screen, click **Finish** to complete the installation.

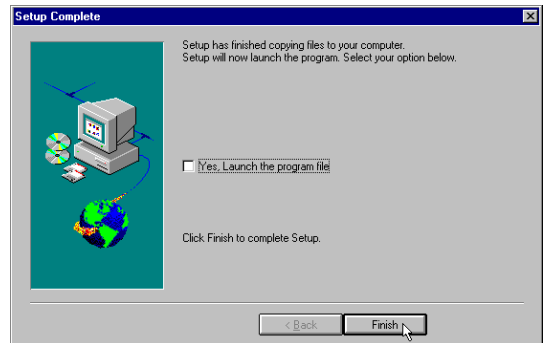

If this is the first time you've installed Modem Station, you may be asked to restart your computer.

USING MODEM STATION

Starting Modem Station

1. If you did not start Modem Station from the Setup program, please start it now.
2. Click Windows **Start** button and then point to **Programs**. Click **U.S. Robotics Modem Station** (or the folder you selected during installation).
3. Click the **Modem Station** icon. This brings up the main menu.

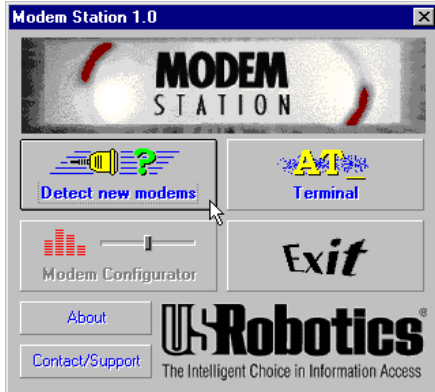

The main menu gives you direct access to the following options:

DETECT NEW MODEMS

This option detects U.S. Robotics modems installed on your system and shows what COM port they are using. Click this option if you are running Modem Station for the first time, if you are changing modems, or if you simply need to know what port your modem is using.

TERMINAL

Terminal allows you to send commands directly to your modem and displays the responses. You can use Terminal to dial up BBSs. In addition, you can configure your modem using Terminal. However, it is much easier to use the Modem Configurator.

MODEM CONFIGURATOR

Modem Configurator provides an easy-to-use interface for entering hard-to-remember commands. Use Modem Configurator for troubleshooting, initial configuration, and tuning your modem for optimum performance. Using the options available in Modem Configurator, you can control nearly every aspect of your modem's performance. We will discuss Modem Configurator's options in more detail in later sections.

ABOUT

The About option provides copyright and version information.

CONTACT/SUPPORT

This option details how to get in touch with 3Com.



TIP: For your convenience, we provide many on-line support avenues. For specific questions, our fax-on-demand service is a good place to start. You can download FAQs, software, and help files from our Web sites and BBS, or receive individualized support via support@usr.com. Type 0000 (4 zeroes) in the subject line of your e-mail.

USING MODEM STATION

Using Detect New Modems

1. Click **Detect New Modems** to bring up the following screen.

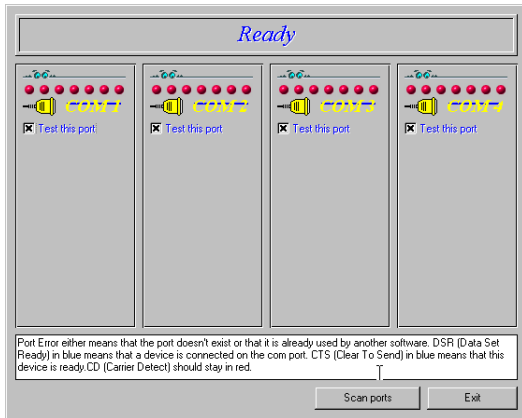

The screen consists of four columns, one for each possible COM port on a PC. You can scan a specific port(s) by selecting the checkbox for that port.

2. Click **Scan** to have Modem Station check for installed modems. This may take a few moments.
3. When the scan finishes, you will see the following display. Your display may differ depending on the type and number of modems installed.

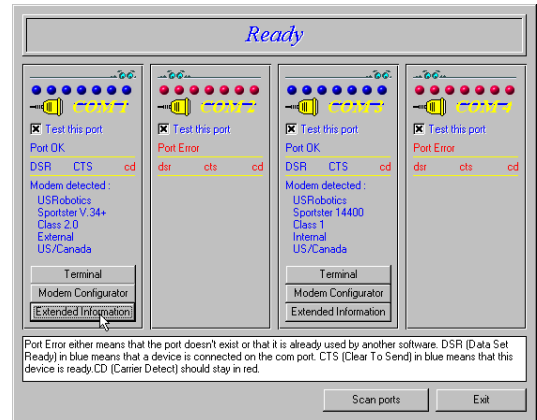

If your modem is installed and configured correctly, Modem Station will find the

USING MODEM STATION

modem and display make and model information under the assigned port. All currently active ports should display “Port OK” under the heading. If a port displays a “Port Error”, it usually means that the port is disabled in system setup.



NOTE: Different systems and BIOSes use different methods of disabling COM ports. As a result, we cannot provide support for disabling/enabling COM ports. Please refer to your system’s documentation or contact the manufacturer of your system for further information.

If you look at the information for the port your modem is using, you will see three buttons. These allow you to access Terminal and

Modem Configurator without going back to the main menu. Extended Information provides detailed information about your modem, previous connections, firmware dates, etc. This next section details using the Terminal option.

Using Terminal

You can access Terminal from either the **Main** menu or the *Detect New Modems* screen. Clicking **Terminal** brings up the *Terminal* window.

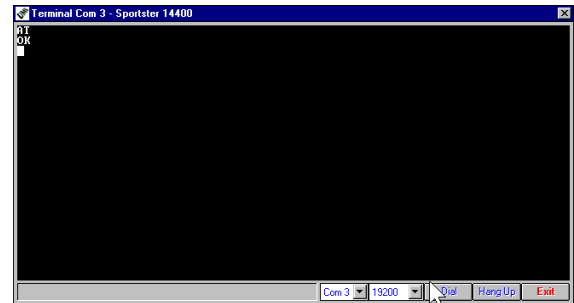

In addition to allowing direct entry of modem commands, the *Terminal* window also allows

USING MODEM STATION

you to dial into Bulletin Boards, listing services, and other online services.

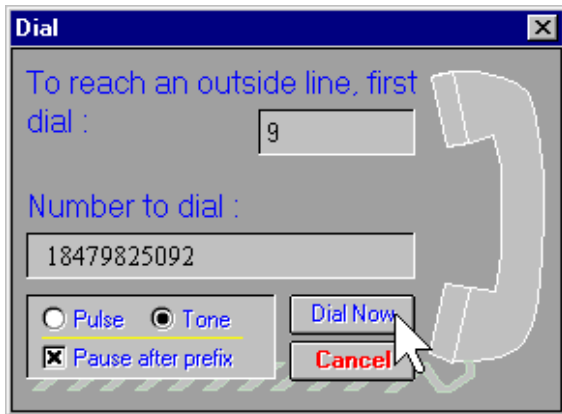

NOTE: Modem Station's Terminal window is provided primarily for troubleshooting convenience. If you frequently use BBSs, you will probably want to use a separate, full-featured Terminal program such as that provided in our RapidComm software.

On the lower part of the Terminal screen, you will see the COM port your modem is currently using. To select another modem, simply click on the arrow and select that modem's assigned port.

To the right of the port settings are the port speed settings. Port speed is the speed at which your computer sends data to the

USING MODEM STATION

modem. We will discuss port speed settings in detail later in this section.

Terminal includes a basic auto dialer.

To have Terminal dial a number for you, click **Dial** to bring up the “Dial” screen.

You need to tell the Dialer a few things about your phone system, such as whether it uses tone or pulse dialing, what digit, if any, you need to dial to get an outside line, and whether the dialer should wait between dialing that digit and the rest of the number. Once you provide this information, simply enter the phone number as if you were dialing a telephone. Click **Dial Now** to dial the number.

You can end a call by clicking **Hang Up** at the bottom of the screen.

When you are finished using Terminal, click **Exit** to return to the screen you accessed it from.

Using Modem Configurator

You can access Modem Configurator from either the **Main** menu or the *Detect New Modems* screen.

Click **Modem Configurator** to bring up this menu.

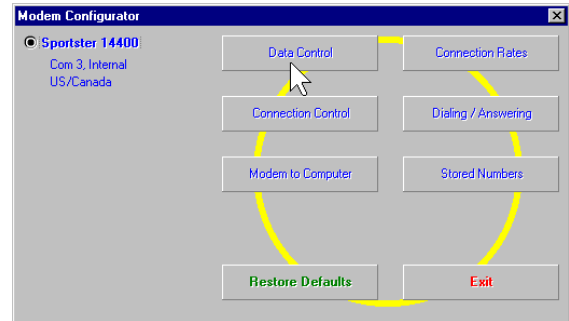

USING MODEM STATION

The **Modem Configurator** menu gives you access to the following options:

Data Control

This is the “Data Control” screen.

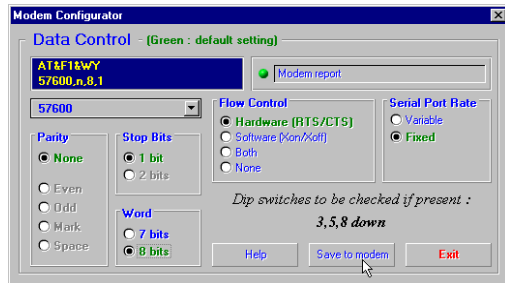

The “Data Control” screen allows you to assign the following basic communications settings:

- ◆ PORT SPEED
- ◆ PARITY
- ◆ STOP BITS
- ◆ WORD LENGTH

- ◆ FLOW CONTROL
- ◆ SERIAL PORT RATE

For information on using these settings, please refer to the “Glossary” at the back of this manual.

Click **Help** for quick definitions of the terminology used in this screen.

In the upper left-hand corner of the screen, you will see the data control commands currently in use.

Once you have entered the Data Control settings, click **Save to Modem**. This stores the settings so that you do not have to re-enter them.

This screen also displays the default DIP switch settings.

USING MODEM STATION



TECHNICAL STUFF: DIP

switches are tiny switches that control a few basic functions on some external modems. On modems without DIP switches, these functions are handled by modem commands.

Click **Exit** to return to the **Modem Configurator** menu.

CONNECTION CONTROL

This is where you adjust your modem's connection and transmission settings.

Click **Connection Control** to bring up this screen.

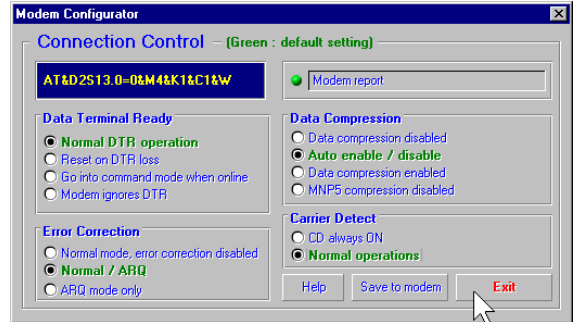

In the upper left hand corner of this screen, you will find the current Connection Control settings.

Use the “Connection Control” screen to configure the following settings:

- ◆ DATA TERMINAL READY (DTR)
- ◆ ERROR CORRECTION
- ◆ DATA COMPRESSION
- ◆ CARRIER DETECT

USING MODEM STATION

For detailed information about these settings, refer to the “Glossary” or the “Technical Quick Reference” sections of this manual.



TIP: On external modems, receiving a Data Terminal Ready signal from the PC causes the TR light to light up.

Click **Help** for quick definitions of terminology used in this screen.

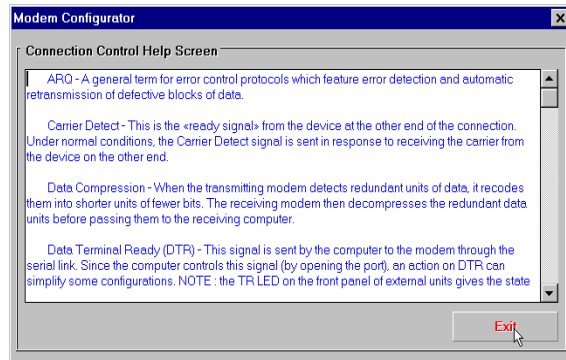

Once you have configured your Connection Control settings, click **Save to Modem** to save your settings.

Using Modem to Computer

These settings control how your modem and computer communicate with each other. They control what you see on your terminal screen and how results are displayed.

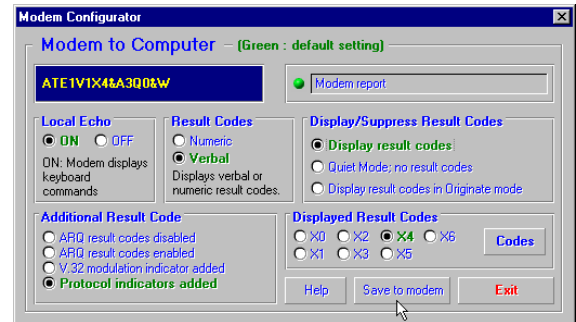

USING MODEM STATION

If you look in the upper left hand corner of the display, you will see the commands currently in use.

The “Modem to Computer” screen allows you to configure the following settings:

- ◆ LOCAL ECHO
- ◆ RESULT CODES
- ◆ RESULT CODE PREFERENCES



TIP: If you type ATDT and see ‘AATDDTT’ on your screen, it is possible that both your software and modem have Local Echo set to ‘ON’. Turn Local Echo ‘OFF’ on EITHER the modem or the software to solve this problem.

For details on using the commands in this screen, refer to the “Glossary” or “Technical Quick Reference” sections of this manual.

Click **Help** to see quick definitions of terminology used in this screen.

This screen also includes a chart of the ways result codes can be displayed. Click **Codes** to view a chart of the display options.

Once you configure your settings, click **Save to Modem** to save your choices.

USING MODEM STATION

CONNECTION RATES

The “Connection Rates” screen allows you to configure modem speeds and protocols.

WARNING! Use caution when changing connection settings. Improper settings may cause your modem to function incorrectly, disconnect, or fail to connect at all.

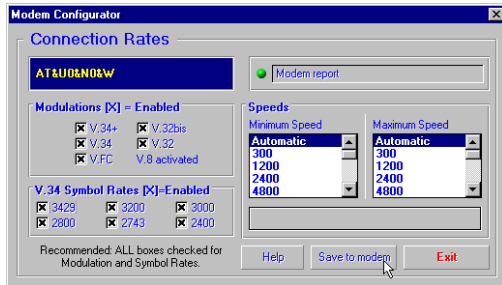

In the upper left hand corner of the screen you will see the current connection commands.

This screen allows you to configure the following settings:

- ◆ MODULATIONS
- ◆ V.34 SYMBOL RATES
- ◆ SPEEDS

Again, once you have selected your settings, click **Save to Modem** to save them.

When you are finished, click **Exit** to return to the **Modem Configurator** menu.

Please refer to the main body of the manual and the “Glossary” for detailed information about the terminology and settings used in this screen.

Click **Help** for quick definitions of terminology used in this screen.

USING MODEM STATION

DIALING/ANSWERING

The next screen allows you to adjust how your modem initiates and receives calls.

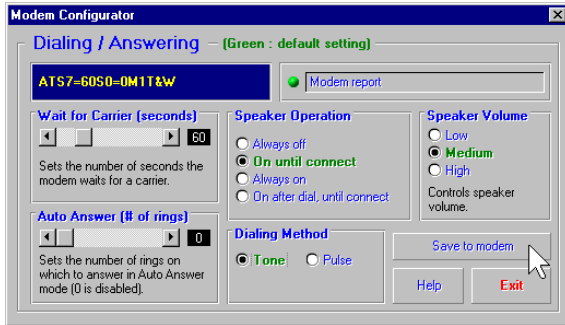

Using this screen, you can configure the following dial settings:

- ◆ WAIT FOR CARRIER
- ◆ AUTO-ANSWER # OF RINGS
- ◆ SPEAKER OPERATION
- ◆ DIALING METHOD
- ◆ SPEAKER VOLUME

STORED NUMBERS

The “Stored Numbers” screen displays the phone numbers currently stored in your modem’s memory.

Use this screen to edit or add numbers stored in the modem’s memory.

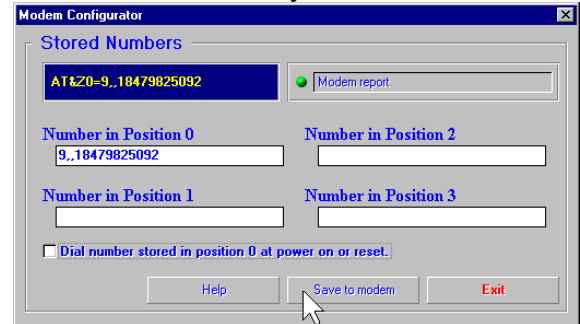

To store a number in your modem’s memory, simply click in one of the entry boxes. Type in the phone number exactly as you would dial it. Position Zero has a special feature. You can set your modem to automatically dial this

USING MODEM STATION

number when your computer is turned on or when it is reset. This is very useful if you are using your modem with a “dumb terminal” or know that you need to connect to a specific bulletin board or listing service.

You can change stored numbers by highlighting them and then typing the new numbers in their place. Once you store your numbers, you can dial them by entering a single command from Terminal Mode:

(for example: **ATDS0**, **ATDS1**, or **ATDS2**).

Your U.S. Robotics modem comes with one phone number already stored in Position 0. If you haven't changed the default, typing **ATDS0** will automatically dial the 3Com BBS.

Once you enter the numbers you wish to store, click **Save to Modem** to store them. Click **Exit** to return to the **Main** menu.

The last option, Restore Defaults, resets your modem to factory specifications. This option is available from many of the screens within Modem Station.



TIP: Restore Defaults will set your modem back to factory specifications. It is a good place to start when troubleshooting.

Using the Extended Information Screens

The “Extended Information” screens provide important and useful information about your modem.

We devote a separate section to the Extended Information screens so that we can explain

USING MODEM STATION

what you'll see (and why it is important to you) as fully as possible.

There are a series of commands used to obtain detailed information from U.S. Robotics modems. Extended Information provides a convenient way to get that important information without memorizing the commands.

From the "Detect New Modems" screen, click **Extended Information**. The "Extended Information" screen provides access to the following information about your modem:

- ◆ ROM CHECKSUM
- ◆ PRODUCT
- ◆ ACTIVE PROFILE
- ◆ STORED PROFILE
- ◆ CONFIGURATION PROFILE
- ◆ LINK DIAGNOSTICS
- ◆ VxD CONFIGURATION

◆ DIAL/SECURITY

Winmodem users will have access to VxD information via these screens. Courier users will have access to Dial/Security information.

Click **ROM Checksum** to bring up the following screen.

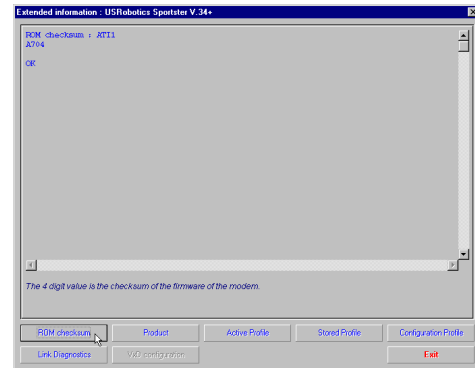

Technicians use the ROM Checksum to verify information stored in the modem's Read Only Memory. For information about the specific

USING MODEM STATION

modem you are using, click **Product** to bring up the next screen.

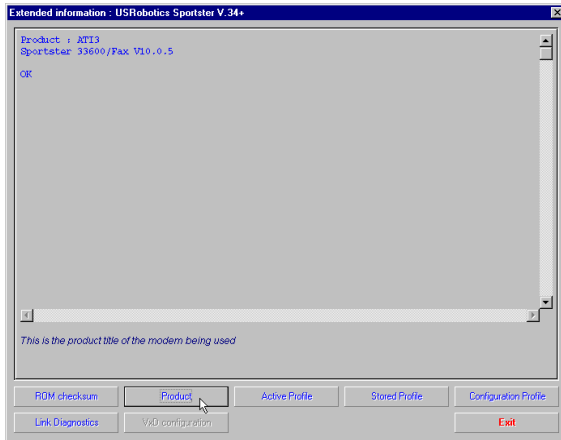

The “Product” screen displays the make and model of your modem.

Your modem is able to store two configurations or “profiles.” Only one can be active at any time.

To see information about the profile in use, click **Active Profile** to bring up the next screen.

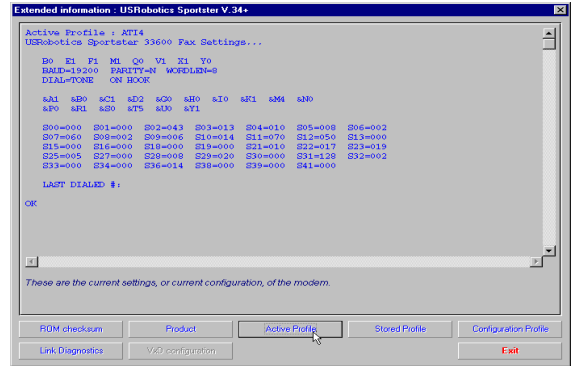

This screen contains information about your modem’s current configuration. Starting from the top, you will see the make and model of your modem. Directly below that, you will see basic commands currently in use followed by the current connection settings.

USING MODEM STATION

The two lines below the connection settings are the advanced commands currently in use.

Below them is a display of the contents of the ‘S-Registers’ for your modem. These registers are special programmable areas of your modem’s memory. They are used to store commands that are too complex to be handled by the standard (or ‘AT’) commands. Just below that you will see the last number dialed.

The next option displays the “Stored Profile” screen. This screen shows the configuration stored in your modem’s NVRAM (special programmable memory). Note that any stored phone numbers are displayed on this screen as well.

The next two screens contain information that our technical support representatives may need if you request support.

Click **Configuration** to bring up the first of these screens.

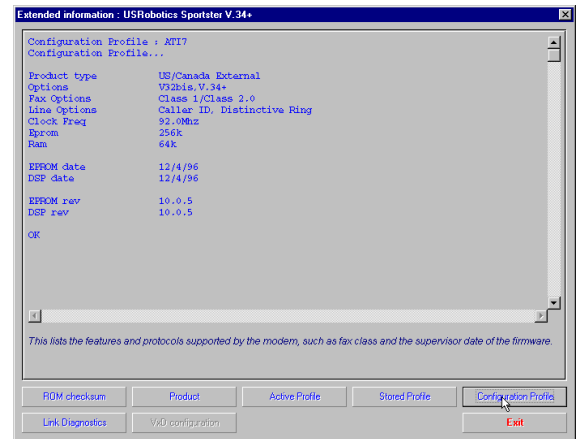

The “Configuration” screen displays the following information about your modem.

- *Product Type* displays the information relating to the make and model of your modem.

USING MODEM STATION

- *Options* displays the protocols available to your modem.
- *Fax Options* displays your fax compatibility.
- *Clock Frequency* displays the speed of the tiny “clock” that controls the timing of operations within the modem.
- *EPROM* displays how much information can be stored in the EPROM (or Supervisor) chip.
- *RAM* displays how much memory your modem has for processing commands and internal functions.
- *Supervisor Date* (or EPROM Date) displays the version date of the ‘firmware’ stored in the Supervisor chip. (The Supervisor chip contains the special software used to control your modem’s functions.) If a support representative asks you for your Supervisor or EPROM date, look here.
- *DSP Date* is the date of the ‘firmware’ that controls the DSP in your modem.
- *Supervisor and DSP rev* (or revisions) are the equivalent of software version numbers.
- *DAA Country* displays the countries your modem is designed for. This is important because phone systems and telecommunications laws vary from country to country.

Click **Link Diagnostics** to bring up the “Link Diagnostics” screen.

USING MODEM STATION

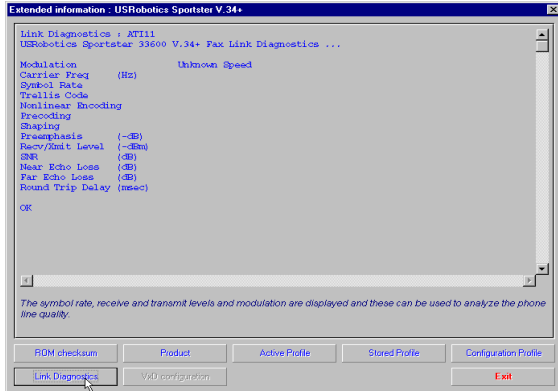

The “Link Diagnostics” screen displays statistics about your last connection. This screen is most often used as an aid in diagnosing connection failures, but it also can provide information about connection speeds and phone line conditions.

- *Modulation* displays the speed and type of connection.
- *Carrier Frequency* displays the electrical frequency of the carrier signal.

- *Symbol Rate* displays the speed of the transmission.
- *Trellis Code, Nonlinear Encoding, Shaping, and Precoding* all refer to methods of handling high speed data transmission.
- The items followed by *(dB)*, *(-dB)*, *(-dBm)*, and *(msec)* refer to variations in the modulation tones that actually carry the information.

The rest of the screen contains information about CRC errors, Block Errors (Blers), resent data, and other data. This information is very important if you experience problems transmitting or receiving data or if you suspect problems with your phone service.

If you are having connection problems, go directly to this screen to get this information. If you save anything to the modem between the

USING MODEM STATION

last connection and this screen, the modem will not save these settings.

Only our U.S. Robotics Winmodems use VxDs, or Virtual Device Drivers. The Winmodem uses special software (called a 'driver') to manage many of the functions handled by hardware in our other modems. If you are using a Winmodem, the Extended Information menu will offer you the option of

clicking on *VxD* to view information on the Winmodem driver. Please refer to your Winmodem manual for detailed information on the Winmodem drivers.

Courier users will see a display of current Dialback/Security settings. Refer to your Courier documentation for instructions on configuring these special features.

U.S. ROBOTICS MODEM UPDATE WIZARD

The *Connections*[®] CD-ROM includes the U.S. Robotics Modem Update Wizard. This software is designed to quickly update your modem to the latest code.



NOTE: You can also obtain this software from our BBS (847-982-5092) or from our World Wide Web page (<http://www.3Com.com/56k>).



NOTE: Complete the instructions in the "Software Installation" chapter (starting on [page 47](#)) before installing the Modem Update Wizard.



NOTE: The following instructions apply to Windows 3.x and Windows 95 users. However, only Windows 95 screens are shown.

Installing the Wizard

1. Insert the *Connections* CD into your CD-ROM drive.
2. Click **Start** and point to **Programs**.
3. Point to **U.S. Robotics Connections**.
4. Click **Connections**.

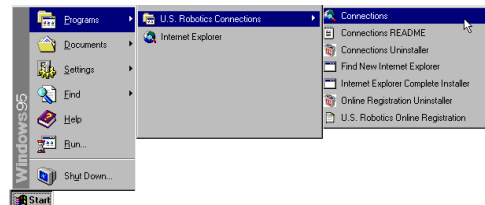

U.S. ROBOTICS MODEM UPDATE WIZARD

5. From the main **Connections** menu, click the **Customer Support** button.
6. Click the **Modem Update Wizard** button.
7. Follow the on-screen instructions to complete the installation.
8. When you see the screen below, the setup is complete. Click **OK**.

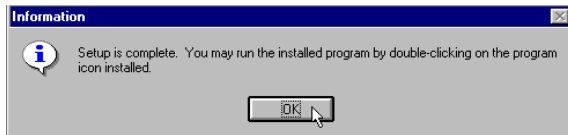

NOTE: For more detailed instructions, see our World Wide Web page (<http://www.3Com.com/56k>).

Updating Your Modem

1. Click **Start**. Point to **Programs**. Then point to **U.S. Robotics Modem Update Wizard**. Finally, point to the **Modem Update Wizard** selection.
2. Follow the on-screen instructions to complete the update process.

TROUBLESHOOTING AND ONLINE HELP RESOURCES

PROBLEM	DIAGNOSIS	POSSIBLE SOLUTION
The computer or software will not recognize the modem.	If you are using an external modem, the modem might not be turned on.	The power switch is located on the back of the modem by the phone jacks.
	You may not be entering modem commands in the proper manner while in terminal mode.	When in terminal mode, type in all upper case (AT) or all lower case (at).
	You may have a COM port/IRQ conflict.	WINDOWS 95 USERS: Uninstall the modem from your computer. In Device Manager, determine what COM port and IRQ settings are free on your system. Set the jumper shunts on your modem's jumper pins to these free settings, using the diagrams on page 13 as a guide. If no IRQ setting is available, you may need to move a device off of an IRQ in order to free it for use by your modem. Make sure you have the correct COM port and IRQ settings in your software and/or in the Windows Device Manager.
	If you are using an external modem, the COM port may not be enabled.	Refer to your computer's manual for information concerning enabling COM ports. This process usually involves altering the BIOS settings, motherboard jumpers, and/or the operating system's settings.

TROUBLESHOOTING AND ONLINE HELP RESOURCES

PROBLEM	DIAGNOSIS	POSSIBLE SOLUTION
The modem displays double characters on your monitor.	Both the modem's and software's local character echoes are turned on.	Disable Local Echo in your software OR on your modem (not both). Turn local echo off on the modem by typing ATE0 and pressing ENTER in your software's terminal mode. To turn the local echo off in the software, refer to its documentation.
The modem won't go off hook to dial or doesn't answer the phone.	You may have plugged your modem's phone cord into a digital line. You might have a bad phone cord connection to your modem. You may have devices between the modem and the phone jack. You may have a poor line connection. If you have voice mail, you may have messages waiting.	Plugging your modem's phone cord into a digital phone line can damage the modem. Call your phone company if you are unsure whether or not your phone line is digital. The phone cord should be plugged into the TELCO jack on the modem and an analog wall phone jack. The phone cord should not exceed 12 feet in length. Use the phone cord included with your modem if possible. Have your phone company make sure that the phone jack is wired properly (tip and ring are on the inside pair of wires). There should be no line splitters, fax machines, or other devices between the modem and the wall jack. Place the call again. Calls are routed differently each time. To verify a valid phone connection, enter the RapidComm Voice software's Terminal mode, type ATX3DT18479825092 (the 3Com BBS), and press ENTER . This string bypasses the dial tone, allowing a connection if the modem is working properly. Answer your voice mail to restore your normal dial tone. Your dial tone may be altered when messages are waiting.

TROUBLESHOOTING AND ONLINE HELP RESOURCES

PROBLEM	DIAGNOSIS	POSSIBLE SOLUTION
The modem won't go off hook to dial or doesn't answer the phone.	Your software may not have auto answer enabled.	Enable the auto answer feature. In the RapidComm Voice software's Terminal mode, type ATSO=1 and press ENTER. NOTE: You need to enable auto answer before every session unless you alter your software's initialization string to permanently enable auto answer.
Both modems exchange carrier signals but fail to establish a link.	You may have a poor line connection.	Try placing the call again. The phone company routes calls differently each time. To verify a valid phone connection, enter the RapidComm Voice software's Terminal mode and type ATX3DT18479825092 and press ENTER (the phone number is the 3Com BBS). This string bypasses the dial tone, allowing a connection if the modem is functioning properly.
Your 56K modem cannot achieve a 56K Internet connection.	Your Internet Service Provider (ISP) may not be ITU 56K/x2 technology capable.	Check http://www.3com.com/56k for a list of ISPs that observe the ITU 56K standard and/or offer x2™ technology. (FCC rules restrict power output of the service providers' modems, limiting download speeds to 53 Kbps.)
	The phone lines in your area not be compatible with 56K technology.	Call your phone company to determine if this might be the problem. You can also run U.S. Robotics' Line Test utility to determine if your phone line is 56K compatible. Visit our Line Test Web page at http://www.3com.com/56k .
	There may be devices between your modem and the phone jack.	Remove all devices between the modem and the phone jack. Make sure the phone cord you are using is no longer than 12 feet. Use the phone cord included with your modem.

TROUBLESHOOTING AND ONLINE HELP RESOURCES

PROBLEM	DIAGNOSIS	POSSIBLE SOLUTION
Your modem won't connect at 2400 bps with a 2400 bps modem.	The modem you're trying to connect with could be an older model that doesn't support error control.	You can disable error control on your modem by typing AT&M0 in terminal mode and pressing ENTER. Now try placing the call to the remote modem again. When finished, reset your modem to enable the error control features. In terminal mode, type ATZ and press ENTER. Note: ATZ4 or AT&F1 are often the best reset strings, as they restore hardware flow control defaults.
Your screen keeps displaying random garbage characters.	<p>You could have a conflict with the remote modem's settings for word length, parity, and stop bits.</p> <p>Your software and modem might not be set to the same flow control settings.</p> <p>The best flow control settings might not be enabled on your modem.</p>	<p>Set your modem's word length, parity, and stop bits the same as the remote modem or BBS you are calling. Typical settings are: data bits=8, stop bits=1, parity=none, flow control=hardware (RTS/CTS)</p> <p>Make sure the software and modem have the same flow control settings (hardware [RTS/CTS] and software [xon/xoff]).</p> <p>In terminal mode, type AT&F1 and press ENTER to load the optimal settings.</p>

TROUBLESHOOTING AND ONLINE HELP RESOURCES

PROBLEM	DIAGNOSIS	POSSIBLE SOLUTION
Your communications software is reporting many cyclic redundancy check (CRC) errors and low characters per second (CPS).	<p>You may have a bad phone line.</p> <p>Optimum flow control settings may not be enabled on your modem.</p> <p>The serial port rate in your communications software may be set too high for your modem's UART or your area's phone lines.</p> <p>The remote site you are dialing into may have trouble with the file transfer protocol.</p> <p>There may be a Terminate and Stay Resident (TSR) program (such as a screen saver or virus scanner) running in the background, disrupting data communications.</p>	<p>Try placing the call again. The phone company routes calls differently each time.</p> <p>In terminal mode, type AT&F1 and press ENTER to load the optimum hardware flow control settings.</p> <p>Lower the serial port rate in your communications software to 57,600 bps, 38,400 bps, or 19,200 bps. Some software programs (including AOL) allow port settings of 14,400, 28,800, and 33,600. These settings are invalid and should not be used. NOTE: The port rate for an 56K modem cannot be set lower than 57,600 if you want to achieve a high-speed connection.</p> <p>Try using a different file transfer protocol. Do not use Xmodem if other protocols are available. Zmodem is the preferred protocol.</p> <p>Disable any Terminate and Stay Resident (TSR) programs running in the background. If you have software running as a TSR, check the software's manual for information about disabling its ability to operate as a TSR.</p>

TROUBLESHOOTING AND ONLINE HELP RESOURCES

PROBLEM	DIAGNOSIS	POSSIBLE SOLUTION
<p>Your communications software is reporting many cyclic redundancy check errors (<i>cont.</i>).</p> <p>Errors are constantly occurring in your V.17 fax transmissions.</p>	<p>You may be trying to download a file to a compressed area of your hard disk.</p> <p>Your modem may not have the correct initialization string for fax transmissions.</p> <p>There may be a Terminate and Stay Resident (TSR) program running on your system.</p> <p>Your baud rate may be set too high.</p> <p>You may be trying to fax a compressed file</p> <p>The RapidComm Voice software's port settings may be incorrect.</p> <p>If you are using an external modem, it may not be turned on</p>	<p>Download to an uncompressed area on your hard drive.</p> <p>In your communications software, change the modem initialization string to AT&H3&I2&R2S7=90.</p> <p>Disable any TSR programs (such as screen savers or virus scanners) running in the background. If you have software running as a TSR, see its manual for information about disabling its ability to operate as a TSR.</p> <p>Lower baud rate to 9600, 7200, or 4800.</p> <p>Open the file in the application in which it was created. Select RapidComm as the printer and then print the file.</p> <p>Make sure the RapidComm Voice software's port settings match your modem's.</p> <p>The power switch is located on the back of the modem by the phone jacks.</p>
<p>The RapidComm Voice software fails to initialize the modem.</p>		

RapidComm™ Voice Software Troubleshooting Tips

PROBLEM: *The lights in the RapidComm Voice software's modem light monitor do not correspond to the actual lights on an external modem.*

DIAGNOSIS: Under certain circumstances, the modem light monitor does not correctly report the activity of the modem. We are aware of this problem and are working to rectify the situation in upcoming versions of the software.

PROBLEM: *The station ID works intermittently.*

DIAGNOSIS: Under certain circumstances (including receiving a fax), the station ID may not work properly.

PROBLEM: *RapidComm Voice software does not work properly at 115.2 kbps.*

DIAGNOSIS: The presence of disk compression software on your system hampers the RapidComm Voice software's ability to work properly at 115.2 kbps. Removal of the disk compression software from your system will allow RapidComm Voice software to operate properly at 115.2 kbps.

If Plug and Play Does Not Detect Your Modem

1. Click Windows 95 **Start** and click **Shut Down**. When asked if you wish to shut down your computer, click **Yes**. When Windows 95 indicates that it is safe to turn off your computer, turn it off and wait 15 seconds. Then turn the computer back on. Windows 95 may detect your modem upon this restart even if it did not detect the modem during the initial installation. If you see screens indicating that new hardware has been detected by Windows 95, turn to “Installing the Modem Drivers” ([page 27](#) for internal modems, [page 39](#) for external modems). If not, continue with the next step.

2. Click Windows 95 **Start**, point to **Settings**, and click **Control Panel**. Double-click the **System** icon and then click the **Device Manager** tab on the “System Properties” screen. Look for “Other Devices” or “Unknown Devices” in the list that appears. If you do not see either of these options in the list, continue with the next section to learn about our support options. If you do see one of these options, double-click the option. If the description that appears matches the modem you are trying to install, click the **Remove** button. Click **OK** when Windows asks if you wish to remove the device. Next, restart the computer as described in step 1 on this page. If the computer does not detect the modem after this second restart, please continue reading to learn about our support options.

Online Help Resources

Connecting to the 3Com BBS

To connect to the 3Com Bulletin Board System, follow these steps:

1. Start your fax/data communications software.
The software settings for the BBS are:

ANSI terminal emulation
Data Bits: 8
Parity: None
Stop Bits: 1

2. Put the software in Terminal mode.
3. Type **ATDS0** (the last character is a zero) and press **ENTER**.

 **NOTE: ATDS0 (the last character is a zero) automatically dials 1-847-982-5092, the 3Com BBS.**

If this is your first time connecting to our BBS, you will be asked to enter your name, create a password of your choice, and to fill out a questionnaire. The introductory screen will look like the one shown below.

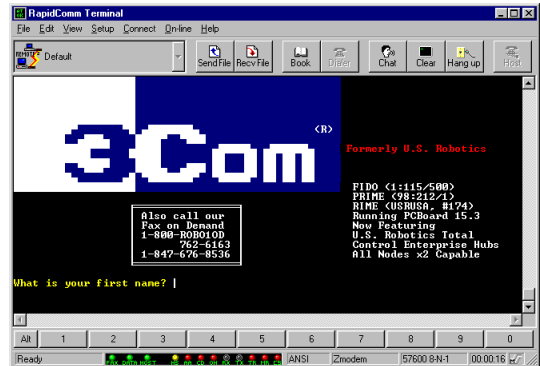

TROUBLESHOOTING AND ONLINE HELP RESOURCES

The BBS gives you access to customer and technical support documents and the BBS library which contains hundreds of helpful files and tips to help simplify using your modem.

When you are ready to leave the BBS, type **G** (for “good-bye”) from the main menu.

3Com offers a number of other online technical support options for our U.S. Robotics modems. Choose any one of the following options if you need help with or want to learn more about your new modem.

Internet FTP

Provides free library containing the same files as the BBS site. FTP to **ftp.usr.com**.

Internet on Demand

Provides automatic technical support through a library containing product information, quick

reference cards, and installation help. To obtain an index of available documents, send a blank e-mail to **support@usr.com**. To have a document e-mailed to you, send the document's number as the subject.

World Wide Web

A U.S. Robotics Home Page containing the same information as the Internet on Demand listing. Log on to:

www.usr.com/home/online

CompuServe

Access the same information as the Internet FTP site. The 3Com forum address is **GO THREECOM**. Address private messages to **76711,707**.

America Online

Go to the **Keyword** field and type **3COM** to connect to various 3Com resources, such as file libraries, message boards, online customer support, and product announcements.

Technical Support Hotline

Technical questions about 3Com modems can also be answered by technical support representatives. The hotline is a toll call. In order to save both time and expense, you should do the following before calling:

1. Click the Windows 95 **Start** button.
2. Point to **Programs** and then click **RapidComm Voice**. (If you have not installed RapidComm Voice, see the section title “Software Installation” on [page 47](#).)
3. Enter RapidComm Voice’s terminal mode by clicking the **Terminal** button.

4. Type **ATI7** and press **ENTER**.
5. The information that appears will be useful to the technical support representative who attempts to troubleshoot your problem when you call. Select **Print** from the **File** menu or leave the information on screen.

Hotline (847) 982-5151
(Hours: 8:00 am - 6:00 pm CST)

Priority No-Hold Service

3Com also staffs its own 900 fee-based number for immediate assistance. These lines are staffed from 8 a.m. - 6 p.m. CST Monday through Friday.

No-Hold line 900-555-USR1

There is a \$1.50 per minute charge which will appear on your local phone bill. You must be 18 or older or have parental permission. (Service available in United States only.)

Are You Still Having Problems?

- Review this manual.
- Call or visit your modem dealer. They may be able to assist you.
- If your dealer can't help you, contact 3Com Customer Support. When you call, specify your modem serial number (found on the modem and on the outside of the box), the software being used, and, if possible, have the contents of your ATI7 screen available.

If You Need to Return the Modem to Us

Contact 3Com Customer Support. If the support representative determines that you need to return

the modem, you will receive an SRO (Service Repair Order) number. You must have an SRO number before returning the modem to us. Ship the unit, postage paid, in a strong box made of corrugated cardboard with plenty of packing material. **DO NOT** send the modem back in the original box. Send **ONLY** the modem (**NOT** the power supply, manuals, CD-ROM, etc.). Include your SRO number, name, and address on the shipping label as well as inside the package. If possible, send the package via a courier capable of tracking the progress of the shipment. Ship to the following address:

**3Com
Attn: RMA
SRO#
6201 W. Oakton, East Dock
Morton Grove, IL 60053**

GLOSSARY

Cross references are printed in **boldface**. Cross references to items also found in the “Technical Quick Reference” chapter are printed in *italics*.

analog loopback

A modem self-test in which data from the keyboard or an internal test pattern is sent to the modem's transmitter, turned into analog form, looped back to the receiver, and converted back into digital form.

analog signals

A variety of signals and wavelengths that can be transmitted over communications lines such as the sound of a voice over the phone line.

answer mode

The mode used by your modem when answering an incoming call from an originating modem. The transmit/receive frequencies are the reverse of the originating modem, which is in **originate mode**.

application

A computer program designed to perform a specific task or set of tasks. Examples include word processing and spreadsheet applications.

ARQ

Automatic Repeat reQuest. A function that allows your modem to detect flawed data and request that it be retransmitted. See **MNP** and **V.42**.

GLOSSARY

ASCII

American Standard Code for Information Interchange. A code used to represent letters, numbers, and special **characters** such as \$, !, and /.

asynchronous transmission

Data transmission in which the length of time between transmitted **characters** may vary. Because characters may not be transmitted at set intervals, **start/stop** bits are used to mark the beginning and end of each character.**auto answer**

Sets the modem to pick up the phone line when it detects a certain number of rings. See S-register S0 in the “Technical Quick Reference.”

auto dial

A process where your modem dials a call for you. The dialing process is initiated by sending an *ATDT* (dial tone) or *ATDP* (dial pulse) command followed by the telephone number. Auto dial is used to dial voice numbers. See command *Dn*.

baud rate

A term used to measure the speed of an analog transmission from one point to another. Although not technically accurate, baud rate is commonly used to mean **bit rate**.

binary digit

A 0 or 1, reflecting the use of the binary numbering system. Used because the computer recognizes either of two states, OFF or ON. Shortened form of binary digit is bit.

GLOSSARY

bit rate

Also referred to as transmission rate. The number of **binary digits**, or bits, transmitted per second (**bps**). Communications channels using analog modems are established at set bit rates, commonly 2400, 4800, 9600, 14,400, 28,800 and higher.

bits per second (bps)

The bits (**binary digits**) per second rate. Thousands of bits per second are expressed as kilobits per second (kbps).

buffer

A temporary memory area used as storage during input and output operations. An example is the modem's command buffer.

byte

A group of **binary digits** stored and operated upon as a unit. Most often the term refers to 8-bit units or **characters**. One kilobyte (KB) is equal to 1,024 bytes or characters; 640 KB is equal to 655,360 bytes or characters.

carrier

The basic signal altered or modulated by the modem in order to carry information.

character

A representation, coded in **binary digits**, of a letter, number, or other symbol.

GLOSSARY

characters per second (CPS)

A data transfer rate generally estimated from the **bit rate** and the **character** length. For example, at 2400 bps, 8-bit characters with **start/stop bits** (for a total of ten bits per character) will be transmitted at a rate of approximately 240 characters per second (cps). Some **protocols**, such as error-control protocols, employ advanced techniques such as longer transmission **frames** and **data compression** to increase cps.

class 1 and 2.0

International standards used by fax **application** programs and faxmodems for sending and receiving faxes.

cyclic redundancy checking (CRC)

An error-detection technique consisting of a test performed on each block or **frame** of data by both sending and receiving modems. The sending modem inserts the results of its tests in each data block in the form of a CRC code. The receiving modem compares its results with the received CRC code and responds with either a positive or negative acknowledgment.

data communications

The transmission or sharing of data between computers via an electronic medium.

GLOSSARY

data compression table

A table containing values assigned for each **character** during a call under **MNP5** data compression. **Default** values in the table are continually altered and built during each call: The longer the table, the more efficient **throughput** gained.

data mode

Mode used by a modem when sending and receiving data files.

DCE

Data Communications (or Circuit-Terminating) Equipment, such as dial-up modems that establish and control the data link via the telephone network.

default

Any setting assumed, at startup or reset, by the computer's software and attached devices. The computer or software will use these settings until changed by the user or other software.

detect phase

In the **ITU-T V.42** error-control **protocol**, the first stage in establishing if both modems are attempting to connect have **V.42** capability.

dictionary

The term used for compression codes built by the **V.42 bis** data compression algorithm.

GLOSSARY

digital loopback

A test that checks the modem's RS-232 interface and the cable that connects the **terminal** or computer and the modem. The modem receives data (in the form of **digital signals**) from the computer or terminal, and immediately returns the data to the screen for verification.

digital signals

Discrete, uniform signals. In this manual, the term refers to the **binary digits** 0 and 1.

DTE

Data **Terminal** (or Terminating) Equipment. A computer that generates or is the final destination of data.

duplex

Indicates a communications channel capable of carrying signals in both directions. See **half duplex**, **full duplex**.

Electronic Industries Association (EIA)

Group which defines electronic standards in the U.S.

error control

Various techniques that check the reliability of **characters (parity)** or blocks of data. **V.42** and **MNP** error-control **protocols** use error detection (**CRC**) and retransmission of flawed **frames (ARQ)**.

facsimile

A method for transmitting the image on a page from one point to another. Commonly referred to as fax.

GLOSSARY

fax mode

The mode used by a modem to send and receive data in **facsimile** format. See definitions for **V.17**, **V.27ter**, **V.29**.

flow control

A mechanism that compensates for differences in the flow of data into and out of a modem or other device. See commands *&Hn*, *&In*, *&Rn*.

frame

A **data communications** term for a block of data with header and trailer information attached. The added information usually includes a frame number, block size data, error-check codes, and Start/End indicators.

full duplex

Signals can flow in both directions at the same time over one line. In microcomputer communications, may refer to the suppression of the online **local echo**.

half duplex

Signals can flow in both directions, but only one way at a time. In microcomputer communications, may refer to activation of the online **local echo**, which causes the modem to send a copy of the transmitted data to the screen of the sending computer.

Hz

Hertz, a frequency measurement unit used internationally to indicate cycles per second.

GLOSSARY

ITU-T

An international organization that defines standards for telegraphic and telephone equipment. For example, the Bell 212A standard for 1200-bps communication in North America is observed internationally as ITU-T **V.22**. For 2400-bps communication, most U.S. manufacturers observe V.22 bis.

LAPM

Link Access Procedure for Modems. An error-control **protocol** defined in **ITU-T** Recommendation V.42. Like the **MNP** protocols, LAPM uses **cyclic redundancy checking (CRC)** and retransmission of corrupted data (**ARQ**) to ensure data reliability.

local echo

A modem feature that enables the modem to display keyboard commands and transmitted data on the screen. See command *En*.

MNP

Microcom Networking Protocol, an error-control **protocol** developed by Microcom, Inc., and now in the public domain. There are several different MNP protocols, but the most commonly used one ensures error-free transmission through error detection (**CRC**) and retransmission of flawed **frames**.

GLOSSARY

modem

A device that transmits/receives computer data through a communications channel such as radio or telephone lines. It also changes signals received from the phone line back to **digital signals** before passing them to the receiving computer.

nonvolatile memory (NVRAM)

User-programmable random access memory whose data is retained when power is turned off. On the U.S. Robotics modem, it includes four stored phone numbers and the modem settings.

off/on hook

Modem operations that are the equivalent of manually lifting a phone receiver (taking it off-hook) and replacing it (going on-hook).

online fall back/fall forward

A feature that allows high-speed, error-control modems to monitor line quality and fall back to the next lower speed in a defined range if line quality diminishes. As line conditions improve, the modems switch up to the next higher speed.

originate mode

The mode used by your modem when initiating an outgoing call to a destination modem. The transmit/receive frequencies are the reverse of the called modem, which is in **answer mode**.

GLOSSARY

parity

A simple error-detection method that checks the validity of a transmitted **character**.

Character checking has been surpassed by more reliable and efficient forms of error checking, including **V.42** and **MNP 2-4 protocols**. Either the same type of **parity** must be used by two communicating computers, or both may omit parity.

protocol

A system of rules and procedures governing communications between two or more devices. Protocols vary, but communicating devices must follow the same protocol in order to exchange data. The format of the data, readiness to receive or send, error detection and error correction are some of the operations that may be defined in protocols.

RAM

Random Access Memory. Memory that is available for use when the modem is turned on, but that clears of all information when the power is turned off. The modem's RAM holds the current operational settings, a **flow control buffer**, and a command **buffer**.

remote digital loopback

A test that checks the phone link and a remote modem's transmitter and receiver.

remote echo

A copy of the data received by the remote system, returned to the sending system, and displayed on the screen. Remote echoing is a function of the remote system.

GLOSSARY

ROM

Read Only Memory. Permanent memory, not user-programmable.

serial transmission

The consecutive flow of data in a single channel. Compare to parallel transmissions where data flows simultaneously in multiple channels.

start/stop bits

The signaling bits attached to a **character** before and after the character is transmitted during **asynchronous transmission**.

terminal

A device whose keyboard and display are used for sending and receiving data over a communications link. Differs from a microcomputer or a mainframe in that it has little or no internal processing capabilities.

terminal mode

Software mode that allows direct communication with the modem. Also known as command mode.

throughput

The amount of actual user data transmitted per second without the overhead of **protocol** information such as **start/stop bits** or **frame** headers and trailers. Compare with **characters per second**.

GLOSSARY

V.8

The **ITU-T** standard specification that covers the initial handshaking process.

V.17 fax

An **ITU-T** standard for making **facsimile** connections at 14,400 bps, 12,000 bps, 9,600 bps, 7,200 bps.

V.21

An **ITU-T** standard for modems operating in asynchronous mode at speeds up to 300 bps, **full-duplex**, on public switched telephone networks.

V.22

An **ITU-T** standard for modem communications at 1200 bps, compatible with the Bell 212A standard observed in the U.S. and Canada.

V.22 bis

An **ITU-T** standard for modem communications at 2400 bps. The standard includes an automatic link negotiation fallback to 1200 bps and compatibility with Bell 212A/V.22 modems.

V.27 ter

An **ITU-T** standard for **facsimile** operations that specifies modulation at 4800 bps, with fallback to 2400 bps.

V.29

An **ITU-T** standard for **facsimile** operations that specifies modulation at 9600 bps, with fallback to 7200 bps.

GLOSSARY

V.32

An **ITU-T** standard for modem communications at 9600 bps and 4800 bps. V.32 modems fall back to 4800 bps when line quality is impaired.

V.32 bis

An **ITU-T** standard that extends the V.32 connection range: 4800, 7200, 9600, 12,000, and 14,400 bps. V.32 *bis* modems fall back to the next lower speed when line quality is impaired, fall back further as necessary, and also fall forward (switch back up) when line conditions improve (see **online fall back/fall forward**).

V.34

An **ITU-T** standard that currently allows data rates as high as 28,800 bps.

V.34+

An enhancement to **V.34** that enables data transfer rates as high as 33,600 bps.

V.42

An **ITU-T** standard for modem communications that defines a two-stage process of detection and negotiation for **LAPM error control**.

V.42 bis

An extension of **ITU-T** V.42 that defines a specific data compression scheme for use during V.42 connections.

GLOSSARY

Xmodem

The first of a family of **error control** software **protocols** used to transfer files between modems. These protocols are in the public domain and are available from many bulletin board services.

XON/XOFF

Standard **ASCII** control **characters** used to tell an intelligent device to stop/resume transmitting data.

Ymodem

An error-checking **protocol** that can send several files of data at a time in 1024-**byte** (1K) blocks. This protocol can use either checksums or CRC for error checking.

Ymodem G

Similar to **Ymodem**, except it includes no error checking, which makes it faster.

Zmodem

Similar to **Xmodem** and **Ymodem**, except it includes batch transfer, the ability to recover from a partially complete transfer, an autostart feature, and improved efficiency.

REGULATORY INFORMATION AND LIMITED WARRANTY

Manufacturer's Declaration of Conformity

3Com Corporation
7770 North Frontage Road
Skokie, Illinois 60077-2690
U.S.A.

declares that the product *U.S. Robotics® 56K Voice Faxmodem* conforms to the FCC's specifications:

Part 15; Subpart B Class B:

Operation is subject to the following two conditions:

- (1) this device may not cause harmful electromagnetic interference, and
- (2) this device must accept any interference

received including interference that may cause undesired operations.

Part 68:

This equipment complies with FCC Rules Part 68. Located on the bottom of the modem is the FCC Registration Number and Ringer Equivalence Number (REN). You must provide this information to the telephone company if requested.

The REN is used to determine the number of devices you may legally connect to your telephone line. In most areas, the sum of the REN of all devices connected to one line must not exceed five (5.0). You should contact your telephone company to determine the maximum REN for your calling area.

BEFORE YOU BEGIN (WINDOWS 95 USERS)

This equipment uses the following USOC jacks: RJ11C.

This equipment may not be used on coin service provided by the telephone company. Connection to party lines is subject to state tariffs.

An FCC compliant telephone cord and modular plug are provided with this equipment, which is designed to connect to the telephone network or premises wiring using a Part 68 compliant compatible jack. See installation instructions for details.

Caution to the User

The user is cautioned that any changes or modifications not expressly approved by the party responsible for compliance could void the user's authority to operate the equipment.

Industry Canada (IC)

This digital apparatus does not exceed the Class B limits for radio noise emissions from digital apparatus set out in the interference-causing equipment standard entitled *Digital Apparatus*, ICES-003 of Industry Canada.

Cet appareil numérique respecte les limites de bruits radioélectriques applicables aux appareils numériques de Classe B prescrites dans la norme sur le matériel brouilleur: *Appareils Numériques*, NMB-003 édictée par l'Industrie Canada.

UL Listing/CUL Listing

This information technology equipment is UL-Listed and CUL-Listed for use with UL-Listed personal computers that have installation instructions detailing user installation of card cage accessories.

BEFORE YOU BEGIN (WINDOWS 95 USERS)

Connecting to the Telephone Company

It is not necessary to notify the telephone company before installing the modem.

However, the telephone company may request the telephone number(s) to which the U.S. Robotics modem is connected and the regulatory information printed in this section.

Be sure that the telephone line you are connecting the modem to is a standard analog line and not a digital (PBX), party, or coin telephone line.

If the modem is malfunctioning, it may affect the telephone lines. In this case, disconnect the modem until the source of the difficulty is traced.

Fax Branding

The Telephone Consumer Protection Act of 1991 makes it unlawful for any person to use a

computer or other electronic device, including fax machines, to send any message unless such message clearly contains in a margin at the top or bottom of each transmitted page or on the first page of the transmission, the date and time it is sent, an identification of the business or other entity, or other individual sending the message, and the telephone number of the sending machine or of such business, other entity, or individual. (The telephone number provided may not be a 900 number or any other number for which charges exceed local or long-distance transmission charges.)

In order to program this information into your U.S. Robotics modem, refer to the RapidComm manual on the CD-ROM that shipped with your modem. If you're using a different communications software program, refer to its manual.

BEFORE YOU BEGIN (WINDOWS 95 USERS)

Radio and Television Interference

This equipment generates and uses radio frequency energy and if not installed and used properly, in strict accordance with the manufacturer's instructions, may cause interference to radio and television reception. The modem has been tested and found to comply with the limits for a Class B computing device in accordance with the specifications in Part 15 of the FCC rules, which are designed to provide reasonable protection against such interference in a residential installation.

However, there is no guarantee that interference will not occur in a particular installation. If this device does cause interference to radio or television reception, which you can determine by monitoring reception when the modem is installed and when it is removed from the computer, try to

correct the problem with one or more of the following measures:

- Re-orient the receiving antenna (for televisions with antenna reception only) or cable input device.
- Relocate the computer with respect to the receiver.
- Relocate the computer and/or the receiver so that they are on separate branch circuits.

If necessary, consult your dealer or an experienced radio/television technician for additional suggestions. You may find the following booklet, prepared by the Federal Communications Commission, helpful:

How to Identify and Resolve Radio-TV Interference Problems
Stock No. 004-000-0345-4
U.S. Government Printing Office

BEFORE YOU BEGIN (WINDOWS 95 USERS)

Washington, DC 20402

In accordance with Part 15 of the FCC rules, the user is cautioned that any changes or modifications to the equipment described in this manual that are not expressly approved by U.S. Robotics, Inc. could void the user's authority to operate the equipment.

For Canadian Modem Users

NOTICE: The Industry Canada (IC) label identifies certified equipment. This certification means the equipment meets certain telecommunications network protective, operational, and safety requirements as prescribed in the appropriate Terminal Equipment Technical Requirements document(s). The Department does not guarantee the equipment will operate to the user's satisfaction.

Before installing this equipment, users should ensure that it is permissible to be connected to the facilities of the local telecommunications company. The equipment must also be installed using an acceptable method of connection. In some cases, the company's inside wiring associated with a single-line, individual service may be extended by means of a certified connector assembly (telephone extension cord.) The customer should be aware that compliance with the above conditions may not prevent degradation of service in some situations. Currently, telecommunication companies do not allow users to connect their equipment to jacks except in precise situations that are spelled out in tariffing arrangements with those companies.

Repairs to certified equipment should be coordinated by a representative designated by

BEFORE YOU BEGIN (WINDOWS 95 USERS)

the supplier. Any repairs or alterations made by the user to this equipment, or equipment malfunctions, may give the telecommunications company cause to request the user to disconnect the equipment.

For your own protection, make sure that the electrical ground connections of the power utility, telephone lines, and internal metallic water pipe system, if present, are connected together. This precaution may be particularly important in rural areas.

CAUTION: Do *NOT* attempt to make such connections yourself. Instead, contact an electric inspection authority or electrician, as appropriate.

NOTICE: The Ringer Equivalence Number (REN) assigned to each terminal device provides an indication of the maximum number of terminals allowed to be connected to a

telephone interface. The termination on an interface may consist of any combination of devices subject only to the requirement that the sum of the Ringer Equivalence Numbers of all the devices does not exceed 5.

The Ringer Equivalence Number is located on the bottom of the modem's case (external modems) or on the modem's circuit board (internal modems).

BEFORE YOU BEGIN (WINDOWS 95 USERS)

WARRANTY AND REPAIR SERVICE CENTER:

Keating Technologies
25 Royal Crest Court, Suite 200
Markham, ONT L3R 9X4

AVIS: L'étiquette de Industrie Canada identifie le matériel homologué. Cette étiquette certifie que le matériel est conforme à certaines normes de protection, d'exploitation et de sécurité des réseaux de télécommunications. Le Ministère n'assure toutefois pas que le matériel fonctionnera à la satisfaction de l'utilisateur.

Avant d'installer ce matériel, l'utilisateur doit s'assurer qu'il est permis de le raccorder aux installations de l'entreprise locale de télécommunication. Le matériel doit également être installé en suivant une méthode acceptée

de raccordement. L'abonné ne doit pas oublier qu'il est possible que la conformité aux conditions énoncées ci-dessus n'empêche pas le dégradation du service dans certaines situations.

Les réparations de matériel homologué doivent être effectuées par un centre d'entretien canadien autorisé désigné par le fournisseur. La compagnie de télécommunications peut demander à l'utilisateur de débrancher un appareil à la suite de réparations ou de modifications effectuées par l'utilisateur ou à cause de mauvais fonctionnement.

Pour sa propre protection, l'utilisateur doit s'assurer que tous les fils de mise à la terre de la source d'énergie électrique, des lignes téléphoniques et des canalisations d'eau métalliques, s'il y en a, sont raccordé ensemble. Cette précaution est

BEFORE YOU BEGIN (WINDOWS 95 USERS)

particulièrement importante dans les régions rurales.

Avertissement: L'utilisateur ne doit pas tenter de faire ces raccordements lui-même; il doit avoir recours à un service d'inspection des installations électriques, ou à un électricien, selon le cas.

NOTICE: L'Indice d'Equivalence de la Sonnerie (IES) de chaque appareil donne une indication du nombre maximal de terminaux qui peut être branché à l'interface téléphonique. La termination d'une interface peut consister de n'importe quelle combinaison d'appareils sur le réseau, seulement si la somme des IES de tous les appareils n'excède pas 5.

L'Indice d'Equivalence de la Sonnerie (IES) est situé au revers du modem (modems

externes), ou sur le circuit imprimé (modems internes).

Centre de garantie et de service après-vente:

Keating Technologies
25 Royal Crest Court, Suite 200
Markham, ONT L3R 9X4

Limited Warranty

U.S. Robotics Access Corp., a subsidiary of 3Com Corporation, warrants to the original end-user purchaser that this product will be free from defects in materials and workmanship for a period of five years from the date of purchase. During the limited warranty period, and upon proof of purchase, the product will be repaired or replaced (with the same or a similar model, which may be a refurbished model) at U.S.

BEFORE YOU BEGIN (WINDOWS 95 USERS)

Robotics' option, without charge for either parts or labor. This limited warranty shall not apply if the product is modified, tampered with, misused, or subjected to abnormal working conditions (including, but not limited to, lightning and water damage).

THIS LIMITED WARRANTY DOES NOT GUARANTEE YOU UNINTERRUPTED SERVICE. REPAIR OR REPLACEMENT AS PROVIDED UNDER THIS LIMITED WARRANTY IS THE EXCLUSIVE REMEDY OF THE PURCHASER. THIS LIMITED WARRANTY IS IN LIEU OF ALL OTHER WARRANTIES, EXPRESS OR IMPLIED, INCLUDING, BUT NOT LIMITED TO, ANY IMPLIED WARRANTY OF MERCHANTABILITY OR FITNESS

FOR A PARTICULAR USE OR PURPOSE. U.S. ROBOTICS SHALL IN NO EVENT BE LIABLE FOR ANY SPECIAL, INDIRECT, INCIDENTAL, PUNITIVE, OR CONSEQUENTIAL DAMAGES OF ANY KIND OR CHARACTER, INCLUDING, WITHOUT LIMITATION, LOSS OF REVENUE OR PROFITS, FAILURE TO REALIZE SAVINGS OR OTHER BENEFITS, LOSS OF DATA OR USE, DAMAGE TO EQUIPMENT, AND CLAIMS AGAINST THE PURCHASER BY ANY THIRD PERSON, EVEN IF U.S. ROBOTICS HAS BEEN ADVISED OF THE POSSIBILITY OF SUCH DAMAGES.

This limited warranty gives you specific legal rights. You may have others, which

BEFORE YOU BEGIN (WINDOWS 95 USERS)

vary from state to state. Some states do not allow limitations on duration of an implied warranty, or the exclusion or limitation of incidental or consequential damages, so the above exclusion or limitation may not apply to you.

To obtain service under this limited warranty, contact the 3Com Customer Support Department at 847-982-5151 or by mail at:

**3Com
7770 N. Frontage Road
Attn.: Customer Support Dept.
Skokie, IL 60077-2690**

You will be given a Service Repair Order (“SRO”) number to help U.S. Robotics keep track of your limited warranty request. Once you have received your SRO number, take or send the product, postage prepaid and insured, to:

**3Com
Attn: RMA
[your SRO#]
6201 W. Oakton, East Dock
Morton Grove, IL 60053**

Pack the modem in a strong corrugated cardboard box with plenty of packing material. DO NOT send the modem back in its original box. DO NOT send anything but the modem (do not send back the power supply, CD-ROM, documentation, etc.). Send the modem via a courier capable of tracking the progress of the shipment. IMPORTANT: If you send your unit, pack it securely, and be sure that your SRO number is visible on the outside of the package.