



Sun StorEdge™ 3000 Family Rack Installation Guide for 1U Arrays

Sun Microsystems, Inc.
www.sun.com

Part No. 819-4027-11
May 2006, Revision A

Submit comments about this document at: <http://www.sun.com/hwdocs/feedback>

Copyright © 2002–2006 Dot Hill Systems Corporation and others, 2200 Faraday Avenue, Suite 100, Carlsbad, California 92008, USA.

All rights reserved.

Sun Microsystems, Inc. and Dot Hill Systems Corporation may have intellectual property rights relating to technology embodied in this product or document. In particular, and without limitation, these intellectual property rights may include one or more of the U.S. patents listed at <http://www.sun.com/patents> and one or more additional patents or pending patent applications in the U.S. and other countries.

This product or document is distributed under licenses restricting its use, copying distribution, and decompilation. No part of this product or document may be reproduced in any form by any means without prior written authorization of Sun and its licensors, if any.

Third-party software is copyrighted and licensed from Sun suppliers.

Parts of the product may be derived from Berkeley BSD systems, licensed from the University of California. UNIX is a registered trademark in the U.S. and in other countries, exclusively licensed through X/Open Company, Ltd.

Sun, Sun Microsystems, the Sun logo, Sun StorEdge, AnswerBook2, docs.sun.com, and Solaris are trademarks or registered trademarks of Sun Microsystems, Inc. in the U.S. and in other countries.

U.S. Government Rights—Commercial use. Government users are subject to the Sun Microsystems, Inc. standard license agreement and applicable provisions of the FAR and its supplements.

DOCUMENTATION IS PROVIDED “AS IS” AND ALL EXPRESS OR IMPLIED CONDITIONS, REPRESENTATIONS AND WARRANTIES, INCLUDING ANY IMPLIED WARRANTY OF MERCHANTABILITY, FITNESS FOR A PARTICULAR PURPOSE OR NON-INFRINGEMENT, ARE DISCLAIMED, EXCEPT TO THE EXTENT THAT SUCH DISCLAIMERS ARE HELD TO BE LEGALLY INVALID.

Copyright © 2002–2006 Dot Hill Systems Corporation et d'autres, 2200 Faraday Avenue, Suite 100, Carlsbad, Californie 92009, Etats-Unis.

Tous droits réservés.

Sun Microsystems, Inc. et Dot Hill Systems Corporation peuvent avoir les droits de propriété intellectuels relatants à la technologie incorporée dans le produit qui est décrit dans ce document. En particulier, et sans la limitation, ces droits de propriété intellectuels peuvent inclure un ou plus des brevets américains énumérés à <http://www.sun.com/patents> et un ou les brevets plus supplémentaires ou les applications de brevet en attente dans les Etats-Unis et dans les autres pays.

Ce produit ou document est protégé par un copyright et distribué avec des licences qui en restreignent l'utilisation, la copie, la distribution, et la décompilation. Aucune partie de ce produit ou document ne peut être reproduite sous aucune forme, par quelque moyen que ce soit, sans l'autorisation préalable et écrite de Sun et de ses bailleurs de licence, s'il y en a.

Le logiciel détenu par des tiers, et qui comprend la technologie relative aux polices de caractères, est protégé par un copyright et licencié par des fournisseurs de Sun.

Des parties de ce produit pourront être dérivées des systèmes Berkeley BSD licenciés par l'Université de Californie. UNIX est une marque déposée aux Etats-Unis et dans d'autres pays et licenciée exclusivement par X/Open Company, Ltd.

Sun, Sun Microsystems, le logo Sun, Sun StorEdge, AnswerBook2, docs.sun.com, et Solaris sont des marques de fabrique ou des marques déposées de Sun Microsystems, Inc. aux Etats-Unis et dans d'autres pays.

LA DOCUMENTATION EST FOURNIE “EN L'ÉTAT” ET TOUTES AUTRES CONDITIONS, DECLARATIONS ET GARANTIES EXPRESSES OU TACITES SONT FORMELLEMENT EXCLUES, DANS LA MESURE AUTORISEE PAR LA LOI APPLICABLE, Y COMPRIS NOTAMMENT TOUTE GARANTIE IMPLICITE RELATIVE A LA QUALITE MARCHANDE, A L'APTITUDE A UNE UTILISATION PARTICULIERE OU A L'ABSENCE DE CONTREFAÇON.



Adobe PostScript

Contents

- 1. Mounting the Array in Racks and Cabinets 1-1**
 - 1.1 Overview of Rackmount Kits 1-1
 - 1.2 One-Person Installation Requirements 1-2
 - 1.3 Reviewing the Tools 1-3
 - 1.4 Converting Your Front Bezel Locks So the Keys Cannot Be Removed 1-4

- 2. Mounting in Sun Cabinets 2-1**
 - 2.1 Overview of Assembly 2-1
 - 2.2 Rear Bracket Configuration 2-5
 - 2.3 Middle Bracket Configuration 2-12

- 3. Telco Rackmounting 3-1**
 - 3.1 Flushmount Configuration 3-2
 - 3.2 Center-of-Gravity Configuration 3-7

- 4. Powering On and Checking LEDs 4-1**

Mounting the Array in Racks and Cabinets

This document describes mounting Sun StorEdge™ 3000 Family 1U arrays in supported racks and cabinets.

Topics covered in this chapter are:

- Section 1.1, “Overview of Rackmount Kits” on page 1-1
- Section 1.2, “One-Person Installation Requirements” on page 1-2
- Section 1.3, “Reviewing the Tools” on page 1-3
- Section 1.4, “Converting Your Front Bezel Locks So the Keys Cannot Be Removed” on page 1-4

1.1 Overview of Rackmount Kits

For late-breaking news about additional supported racks and cabinets, refer to the Release Notes for the model of the array that you are installing. You can find the Release Notes at:

http://www.sun.com/products-n-solutions/hardware/docs/Network_Storage_Solutions/Workgroup/

Tip – The instructions in this guide can save you a lot of time if you read them carefully. The entire assembly procedure should take less than 30 minutes if you follow all the instructions provided in this guide.

These rack kits are available for all Sun StorEdge 3000 Family 1U (1.75 inches) arrays. The term *array* is used to refer to any of the Sun StorEdge 3000 Family products.

The following table lists the supported cabinets and racks and other required kits, the rackmount kits that apply to each one, and the location of the installation instructions in this guide.

TABLE 1-1 Supported Cabinets With Associated Rackmount Kits

Supported Cabinet or Rack	Rackmount Kit Needed	Installation Instructions
Sun StorEdge 72-inch Expansion Cabinets ¹ SG-(X)ARY030A	XTA-3000-1URK-19UZ	Section 2.2, “Rear Bracket Configuration” on page 2-5
Sun Fire Cabinets SF-(X)CAB, SFE-(X)CAB	XTA-3000-1URK-19UZ	Section 2.3, “Middle Bracket Configuration” on page 2-12
Sun Fire 6800 System F6800-1	XTA-3000-1URK-19UZ	Section 2.3, “Middle Bracket Configuration” on page 2-12
Sun Fire E6900 System E6900-BASE	XTA-3000-1URK-19UZ	Section 2.3, “Middle Bracket Configuration” on page 2-12
Sun Rack 900 Cabinet ² SR9-(X)KM038A-IP	XTA-3000-1URK-19UZ	Section 2.2, “Rear Bracket Configuration” on page 2-5
Standard EIA Cabinets	XTA-3000-1URK-19UZ	Section 2.2, “Rear Bracket Configuration” on page 2-5
Telco flushmount racks	XTA-3000-1URK-19FZ	Section 3.1, “Flushmount Configuration” on page 3-2
Telco center-of-gravity racks	XTA-3000-1URK-19CZ	Section 3.2, “Center-of-Gravity Configuration” on page 3-7

1 The Sun StorEdge 72-inch expansion cabinet requires the X9818A door kit for the Sun StorEdge 3000 Family 1U arrays.

2 The Sun Rack 900 cabinet also requires the X6825A door kit and the X6835A EMI kit with these arrays.

1.2 One-Person Installation Requirements

Two people should install each array; however, one person can install the array:

- In a Sun cabinet if the rail kit contains rear brackets with flanges that provide support
- In a Telco rack if the person has an appropriate equipment lift that can ensure safety and ease of installation

For a one-person installation, you should remove the power supplies and disk drives to reduce weight and to be safe. If possible, position the array on top of another device or shelf in the rack to hold the unit as you attach all the brackets.



Caution – If you have only one person to perform the installation for a Sun cabinet and do not have rear brackets with flanges or special equipment lift, you must remove the power supplies and hard disk drives from the array before installing the array in a rack.

To reduce the weight of the array during the rackmounting procedure, refer to the *Sun StorEdge 3000 Family Installation, Operation, and Service Manual* and follow instructions on removing drives and power supplies for the Sun StorEdge 3120 SCSI array. A fully populated array weighs over 32 pounds (14.51 kilograms); an array without drives and power supplies weighs about 25 pounds (11.34 kilograms).

1.3 Reviewing the Tools

The following tools are used to complete this procedure:

- Medium Phillips screwdriver
- Allen wrench (provided; used with 6-mm. screws and #12-24 x 3/8-inch sockethead screws)



Caution – Do not use any power tools with any procedures. Power tools can strip or damage connections.

1.4 Converting Your Front Bezel Locks So the Keys Cannot Be Removed

The bezel on your array has two locks whose keys can be removed when the locks are in either the locked or open position. It is possible to reconfigure the locks so that the keys cannot be removed.

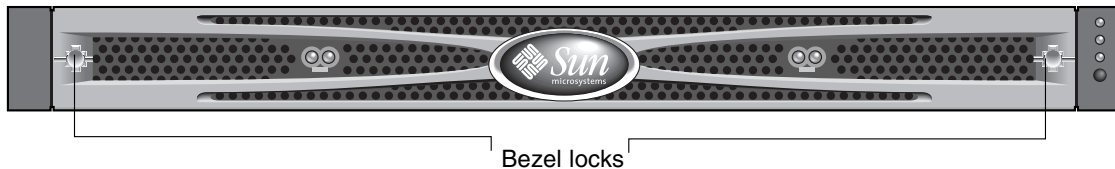

FIGURE 1-1 Front Bezel and Front Bezel Locks of an Array

To change the locks so the keys cannot be removed, follow these steps:

1. Remove the bezel by gently pivoting the swing arms out of their ear sockets, and make sure the key is in the locked position, with the pawl extending horizontally past the edge of the bezel (see the first panel of [FIGURE 1-2](#)).
2. Hold the key in place and use a 12 mm or 3/8-inch nut driver to remove the locking nut that holds the pawl in place as shown in the first panel of [FIGURE 1-2](#).



Caution – Be sure to hold the key in place. Otherwise there is a risk of breaking the small tab on the lock that serves as a stop.

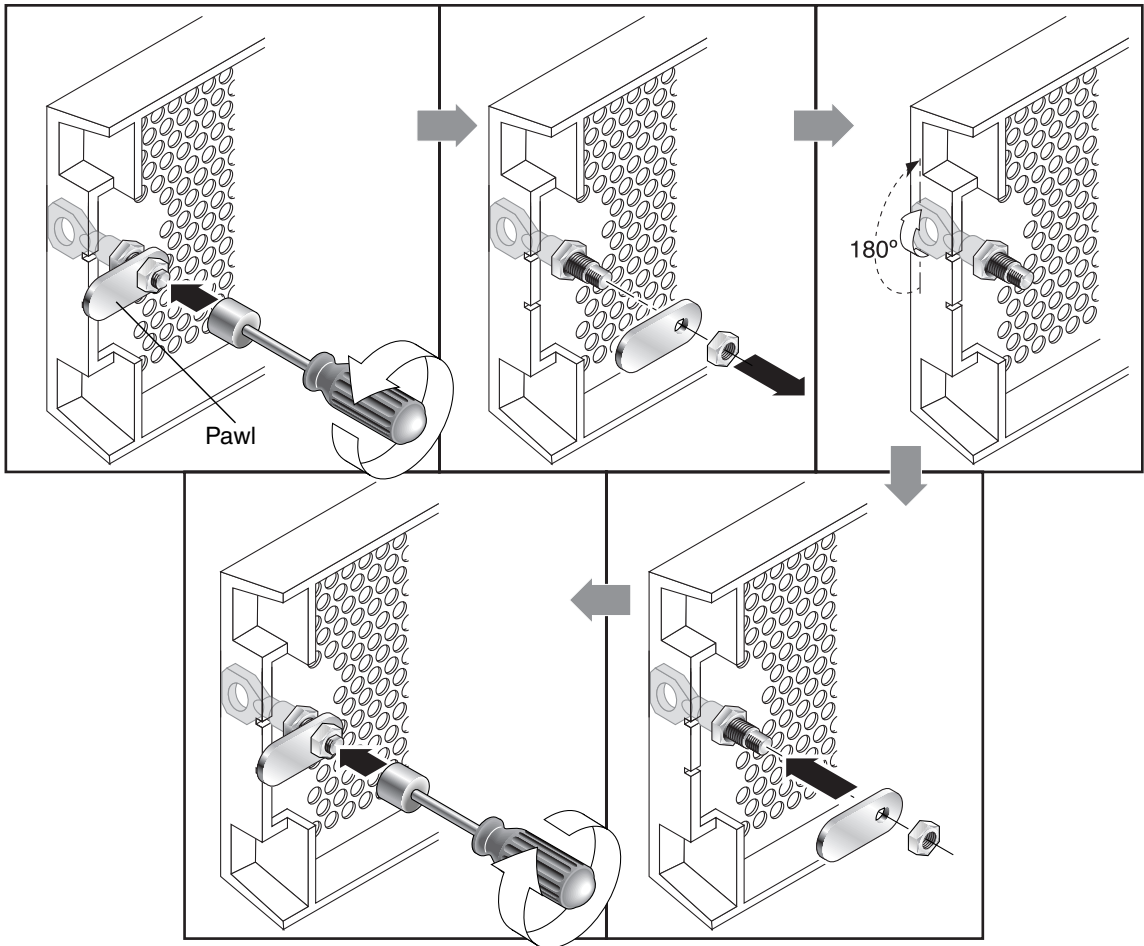

FIGURE 1-2 Sequence of Steps to Change Front Bezel Locks So Keys Cannot Be Removed

3. Lift the pawl off the threaded part of the lock body, as shown in the second panel of [FIGURE 1-2](#).
4. Set the pawl aside, face up, so that you can remember its orientation when you replace it.
5. Use the key to turn the lock 180 degrees, as shown in the third panel of [FIGURE 1-2](#).
6. Replace the pawl in the same orientation as before, as shown in the fourth panel of [FIGURE 1-2](#).
7. Hold the key in place and use the nut driver to refasten the locking nut that holds the pawl in place, as shown in the fifth panel of [FIGURE 1-2](#). Be careful not to cross-thread the nut.



Caution – Be sure to hold the key in place. Otherwise there is a risk of breaking the small tab on the lock that serves as a stop.

8. Replace the bezel.

Note – To convert your bezel locks back so that the keys can be removed, repeat the preceding steps.

Mounting in Sun Cabinets

This chapter explains how to mount Sun StorEdge 3000 Family 1U array by using universal, adjustable mounting brackets for depth ranges between 24 to 36 inches (60.96 to 91.44 cm).

The topics covered are:

- [Section 2.1, “Overview of Assembly” on page 2-1](#)
- [Section 2.2, “Rear Bracket Configuration” on page 2-5](#)
- [Section 2.3, “Middle Bracket Configuration” on page 2-12](#)

2.1 Overview of Assembly

Two configurations exist for Sun cabinets:

- You can mount a cabinet using rear and side brackets for depth ranges between 24 to 36 inches (60.96 to 91.44 cm). [FIGURE 2-1](#) displays a completed installation of a Sun StorEdge 3000 Family 1U array in a standard EIA cabinet using rear and side brackets.
- You can mount a cabinet using middle and side brackets at 24.5 inches (62.22 cm). [FIGURE 2-2](#) displays a completed installation of a Sun StorEdge 3000 Family 1U array in a Sun Fire cabinet using middle and side brackets.

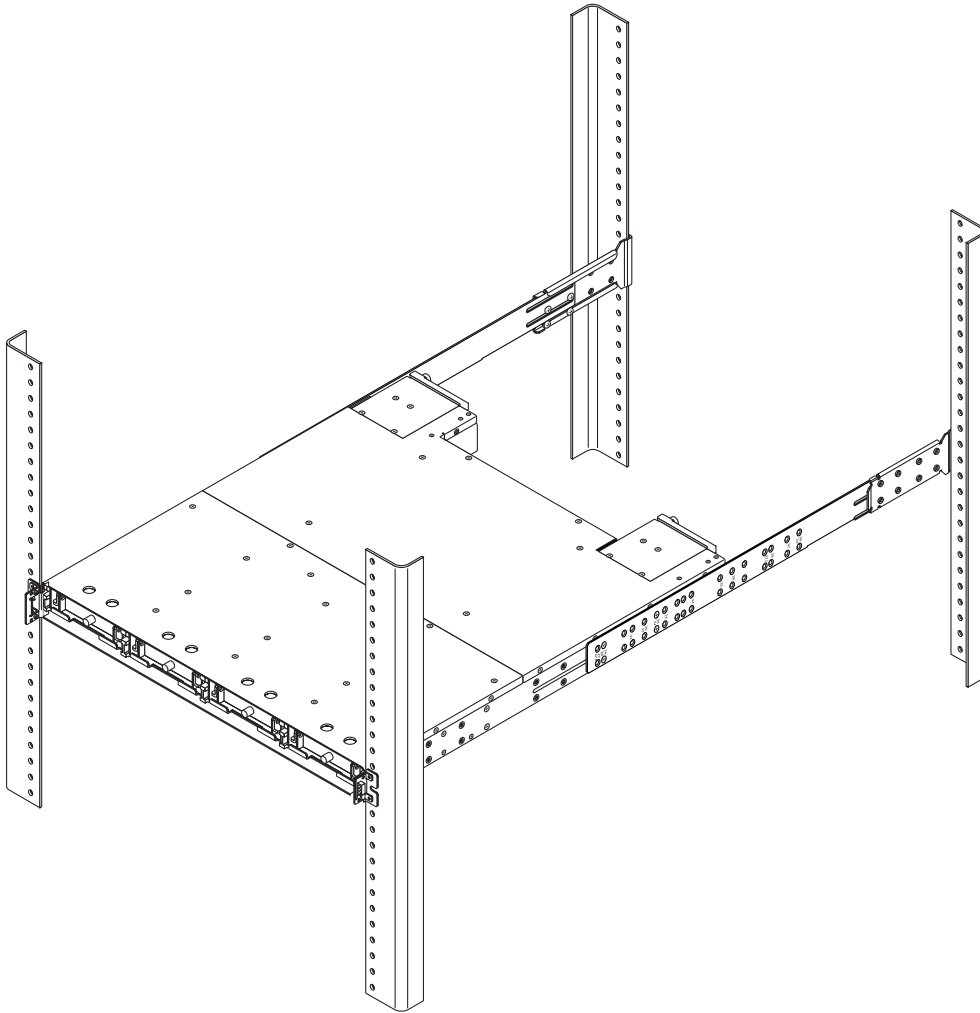

FIGURE 2-1 Rackmounted Cabinet Array Using Rear Brackets With Chassis Ears and Bezels Removed, After Installation

Refer to [FIGURE 2-4](#) during installation.

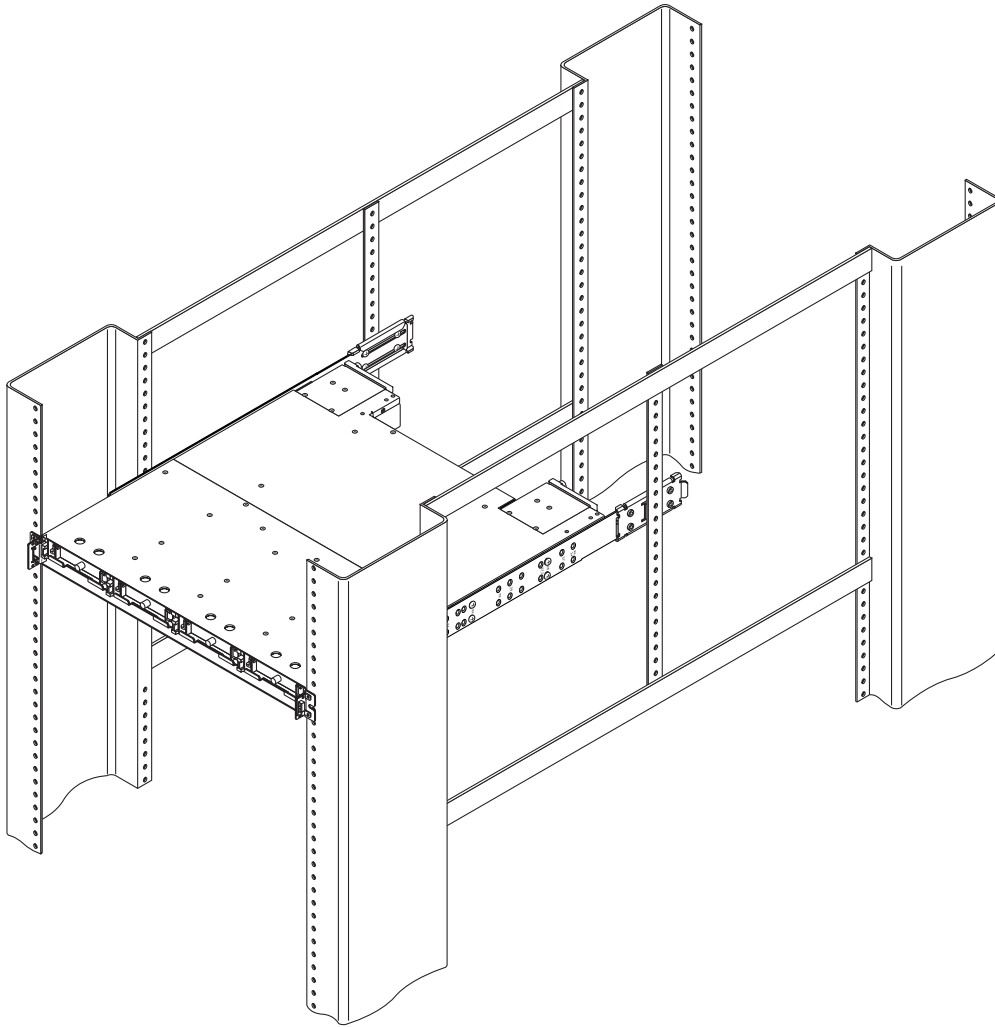

FIGURE 2-2 Rackmounted Cabinet Array Using Middle Brackets With Chassis Ears and Bezels Removed, After Installation

Refer to [FIGURE 2-9](#) during installation.

Note – It is possible for customer-supplied racks to have several sizes of threaded holes. Rackmount kits have several sizes of panhead screws and sockethead screws in order to fit these various racks. Sockethead screws are supplied for the front mounting ears when the diameter of the screw is too large for panhead screws to fit.

Note – When you finish the installation, you will have unused screws left in your rackmount kit. This does not indicate a problem with your installation. Several types of screws are included for different rack configurations, and extra screws are provided in case any are misplaced.

Before mounting the Sun StorEdge 3000 Family 1U array into a 19-inch wide cabinet, check that you have all the rackmount kit components (TABLE 2-1) listed for the rack installation kit you are installing.

TABLE 2-1 XTA-3000-1URK-19UZ Universal Rack Kit, 1U, 19-inch Wide, 24–36 Inches Deep (594-2315-01)

Major Components			Fasteners		
Qty.	Part Number	Description	Qty.	Part Number	Description
1	71-00000763	bracket, left side, short	16	01-00000142	screws, #8-32 x 3/16-in. flathead, maximum torque: 18-in-pounds
1	71-00000764	bracket, right side, short	10	01-00000186	screws, #8-32 x 1/4-in. panhead, maximum torque: 18-in-pounds
2	79-00000100	front brackets, support	12	01-00000192	screws, #10-32 x 3/8-in. panhead, maximum torque: 24-in-pounds
2	71-00000867	rear brackets	3	01-00000151	screws, 6-mm socket cap, maximum torque: 24-in-pounds
2	71-00000750	middle bracket	10	01-00000152	screws, 6-mm panhead, maximum torque: 24-in-pounds
			12	01-00000150	screws, 5-mm panhead, maximum torque: 20-in-pounds
			8	02-00000018	#10 flat washers
1	09-00000064	Allen 5mm wrench for 6mm socket cap screws			

Note: The U-shaped front flanges support the side brackets and eliminate the need for a second person to support the array while assembling and tightening screws.

2.2 Rear Bracket Configuration

Review [Section 1.2, “One-Person Installation Requirements”](#) on page 1-2 and [Section 1.3, “Reviewing the Tools”](#) on page 1-3 before rackmounting the array.

Refer to the parts list in [TABLE 2-1](#) and the illustration in [FIGURE 2-1](#) during installation. The table lists the major components and fasteners required to install an array into the cabinet.

Note – It is possible for customer-supplied racks to have several sizes of threaded holes. Rackmount kits have several sizes of panhead screws and sockethead screws in order to fit these various racks. Sockethead screws are supplied for the front mounting ears when the diameter of the screw is too large for panhead screws to fit.



Caution – Do not use any power tools with any procedures. Power tools can strip or damage connections.

1. Determine the position at which the array will be installed.

Install the first array at the *bottom* of the rack, and install each subsequent chassis above the previous one.

Note – Keep all hardware items in plastic bags until you are ready to use them. This will enable you to correctly identify the screws and avoid confusion.

- 2. Before rackmounting, be sure to check your site location and confirm that you have cables with adequate lengths to connect to servers and to power outlets.**
- 3. (Optional). Before you mount the unit, screw the front support brackets (79-00000100) into position on the rack face. The front support brackets enable one person to easily position and support the front of the unit in the rack.**

a. Attach each front bracket to the rack face (See [FIGURE 2-3](#)):

To connect the front brackets (79-00000100), use a minimum of two screws per front bracket.

Use the appropriate screws for the rack:

- #10-32 x 3/8-inch (01-00000192) panhead screws
- or
- 5-mm (01-00000150) panhead screws
- or
- 6-mm (01-00000152) panhead screws

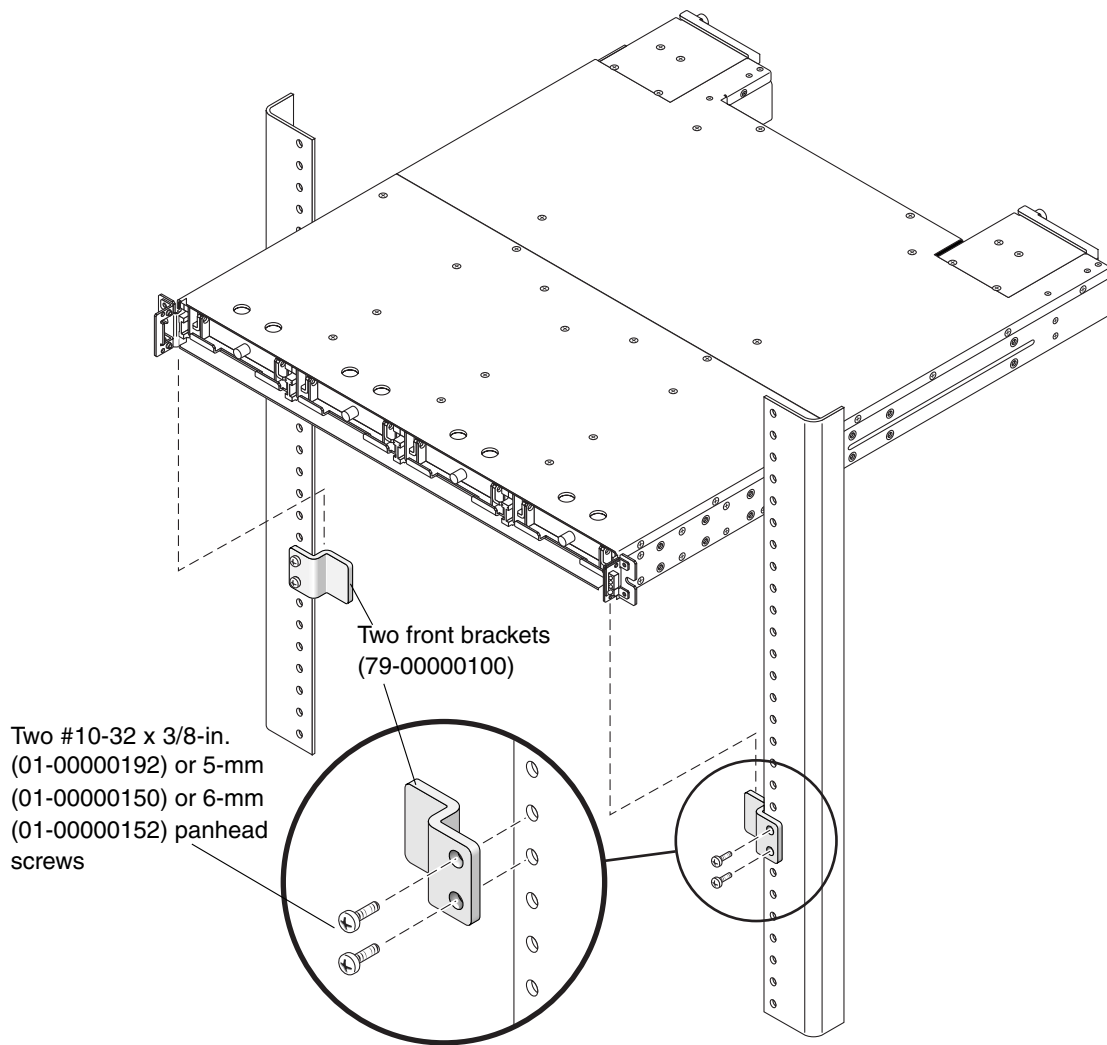

FIGURE 2-3 Front Bracket Position on the Rack Face

4. Remove the bezel (the front faceplate) and the two plastic ear caps from the front of the chassis.



Caution – The plastic ear covers are snap-on parts that require some care when you remove them. Remove the right plastic ear caps carefully to avoid breaking the push button reset switch that is directly behind the ear cap.

To remove a plastic ear cap (both caps are removed the same way):

- a. Grasp both sides of the cap.
- b. With minimal force, pull the cap straight out from the array until it disengages.

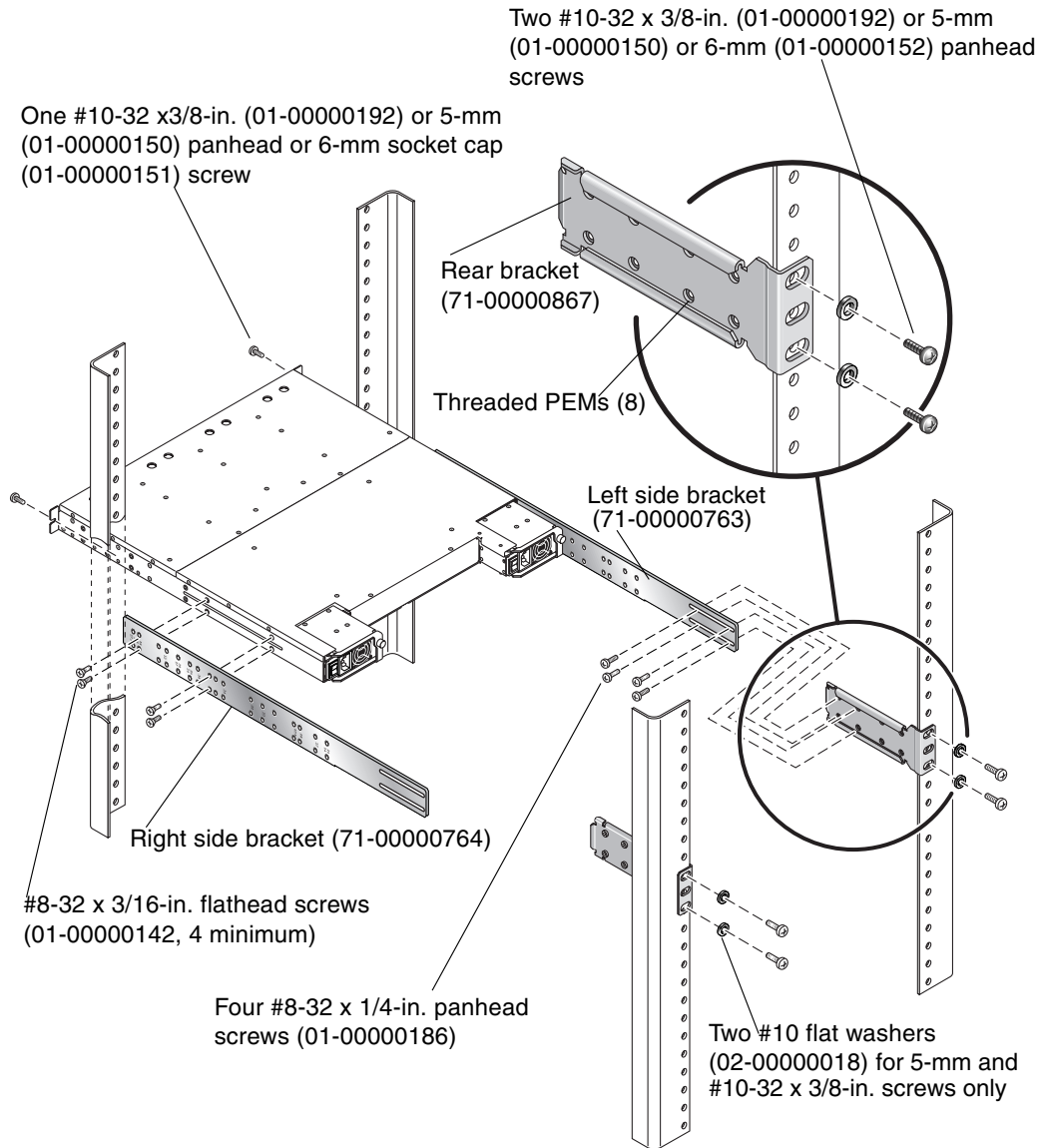

FIGURE 2-4 Cabinet Rackmount with Rear Brackets

Note – Alternate screws can be used with the appropriate racks: 5-mm panhead screws (front and back), or 6-mm sockethead screws (front) and 6-mm panhead screws (back).

Note – Keep all hardware items in plastic bags until you are ready to use them. This will enable you to correctly identify the screws and avoid confusion.

5. Attach the side brackets to the left and right sides of the chassis.

Attach up to eight #8-32 x 3/16-inch flathead machine screws (01-00000142) on each side to allow some adjustment to the placement. Make sure you use at least four screws on each side (six screws per side is recommended).

Left bracket (71-00000763), inside view (see other side of bracket for alignment marks)



Right bracket (71-00000764), outside view with alignment marks

FIGURE 2-5 Side Brackets

Note – The right and left side brackets may look identical, but they are slightly different. Each side bracket is clearly stamped with numbers. Position the side brackets with the number side of the bracket facing out and the holes closest to the edge of the bracket mounted to the bottom of the chassis. See [TABLE 2-1](#) for the rack kit contents and part numbers.

a. Use the alignment marks (depth in inches) stamped into the side brackets to position the brackets and screws.

There are markings for several depths: 24, 24.5, 26, 27, 28, 30, 32, 34, and 36 inches.

Determine the depth you require and align the last (rearmost) alignment mark for each depth on the side bracket to the last mounting holes on the chassis.

Make sure the alignment mark corresponding to the depth you want lines up with the top and bottom threaded holes on the side of the chassis closest to the rear.

- b. Insert the first two screws on each side through the side bracket slots above and below the appropriate alignment mark (24, 24.5, 26, 27, 28, 30, 32, 34, or 36) and into the last pair of rear threaded holes in the chassis.

In the illustration below, the 34-inch alignment mark is positioned above and below the last pair of rear threaded holes. This positions the array for a 34-inch deep rack.

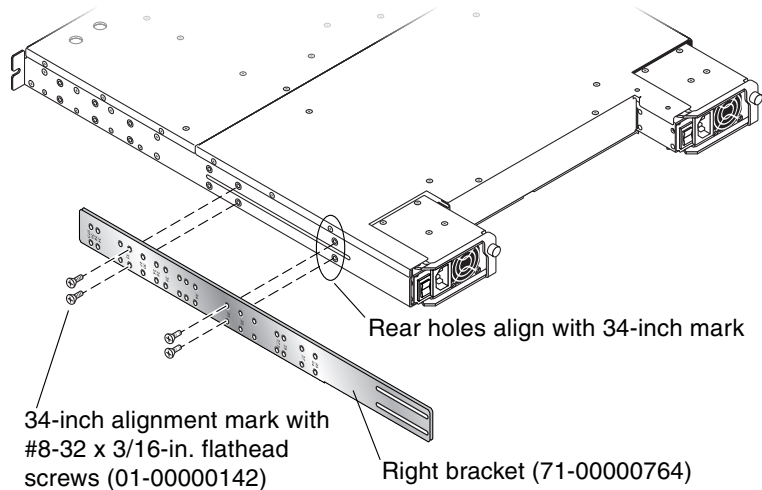

FIGURE 2-6 Aligning a Side Bracket with the Rear Threaded Holes on the Side of the Array

- c. Insert up to six other screws through the side bracket slots into the other threaded holes in the chassis. Use a minimum of four screws for each side bracket.
6. Attach the rear brackets to the rear vertical posts using a total of four screws and four washers (two screws to attach each bracket to a post). (See [FIGURE 2-4](#).)

Attach each rear bracket with two of the appropriate screws for the posts:

- #10-32 x 3/8-inch panhead screws (01-00000192) with #10 washers (02-00000018)
or
- 5-mm panhead screws (01-00000150) with #10 washers (02-00000018)
or
- 6-mm panhead screws (01-00000152)

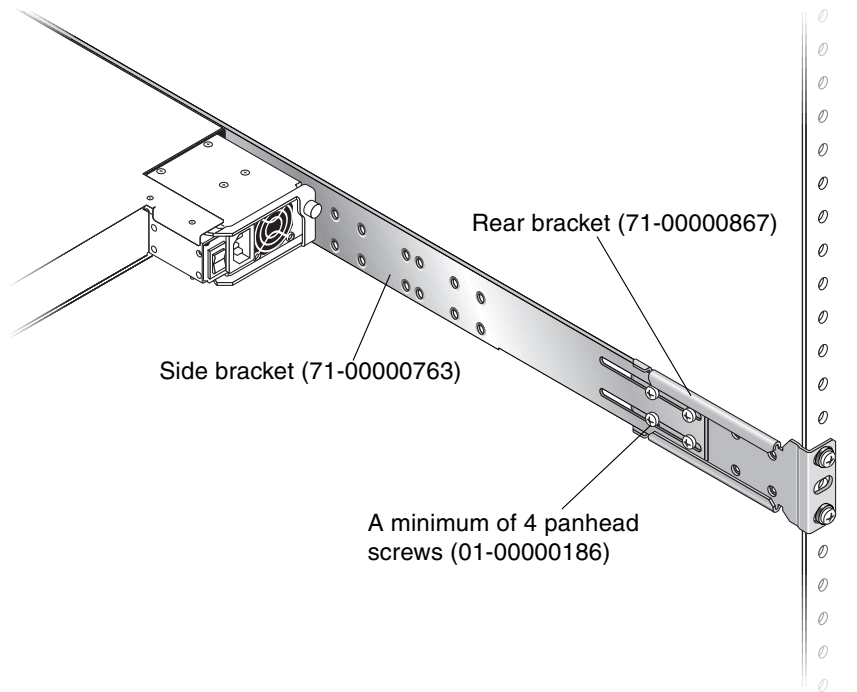

FIGURE 2-7 Example of Rear and Side Brackets Assembled

Note – Not all racks allow mountings in the location shown in the preceding figure.

7. **Lift the chassis and slide the side brackets into the rear brackets, which are attached to the rear posts. (See [FIGURE 2-7](#))**

Adjust the depth of these brackets so that the rear slotted cutouts on the *side brackets* align with the four PEM nuts in the *rear brackets*.

- a. **Insert a minimum of four each and up to a total of eight #8-32 x 1/4-inch panhead screws (01-00000186) through the side bracket slots and through the rear bracket holes.**
8. **Attach and secure the array's front mounting ears with two appropriate screws (one screw into each ear, as shown in [FIGURE 2-4](#)):**
 - #10-32 x 3/8-inch panhead screws (01-00000192)
or
 - 5-mm panhead screws (01-00000150)
or
 - 6-mm socket cap screws (01-00000151)

Note – You will have unused screws left in your rackmount kit. This does not indicate a problem with your installation. Several types of screws are included for different rack configurations, and extra screws are provided in case any are misplaced.

9. Remount all drives and power/fan modules into the array.
10. If you mounted the unit using the optional front support brackets, remove them from the rack face using a standard screwdriver.
11. Reattach the two plastic ear caps and the bezel onto the front of the chassis.
Each plastic cap is replaced the same way, but be sure the cap with the LED labels on the right ear.
 - a. Align the inside round notches of the cap with the round cylindrical posts (ball studs) on the ear.
 - b. Push the top and bottom of the ear cap onto the ear, pressing in toward the center of the array.
 - c. Continue pushing the top and bottom of the ear cap onto the ear until the ear cap snaps in flush.

Do not use force when placing a cap on an ear.



Caution – Be careful to avoid “wedging” the reset button below the LEDs on the right ear when you replace the plastic cap over it.

- d. Insert the bezel swing arms into the chassis ear holes.
 - e. Lift the bezel into position and press it onto the front of the chassis until it is flush with the front.
 - f. Use the key to lock both bezel locks.
12. Connect power cables to the chassis, power on, and check for proper operation of the LEDs.

For details on powering on and checking LEDs, see [Chapter 4](#).

Refer to the *Sun StorEdge 3000 Family Installation, Operation, and Service Manual* for your array to see more information about cable connections and LED functionality.

2.3 Middle Bracket Configuration

Be sure to review [Section 1.2, “One-Person Installation Requirements”](#) on page 1-2 and [Section 1.3, “Reviewing the Tools”](#) on page 1-3 before rackmounting the array.

Refer to the parts list in [TABLE 2-1](#) and the illustration in [FIGURE 2-2](#) during installation. The table lists the major components and fasteners required to install an array into the cabinet.

Note – It is possible for customer-supplied racks to have several sizes of threaded holes. Rackmount kits have several sizes of panhead screws and sockethead screws in order to fit these various racks. Sockethead screws are supplied for the front mounting ears when the diameter of the screw is too large for panhead screws to fit.



Caution – Do not use any power tools with any procedures. Power tools can strip or damage connections.

1. Determine the position at which the array will be installed.

Install the first array at the *bottom* of the rack, and install each subsequent chassis above the previous one.

Note – Keep all hardware items in plastic bags until you are ready to use them. This will enable you to correctly identify the screws and avoid confusion.

2. Before rackmounting, be sure to check your site location and confirm that you have cables with adequate lengths to connect to servers and to power outlets.

3. (Optional). Before you mount the unit, screw the front support brackets (79-00000100) into position on the rack face. The front support brackets enable one person to easily position and support the front of the unit in the rack.

a. Attach each front bracket to the rack face (See [FIGURE 2-8](#)):

To connect the front brackets (79-00000100), use a minimum of two screws per front bracket.

Use the appropriate screws for the rack:

- #10-32 x 3/8-inch (01-00000192) panhead screws
or
- 5-mm (01-00000150) panhead screws
or
- 6-mm (01-00000152) panhead screws

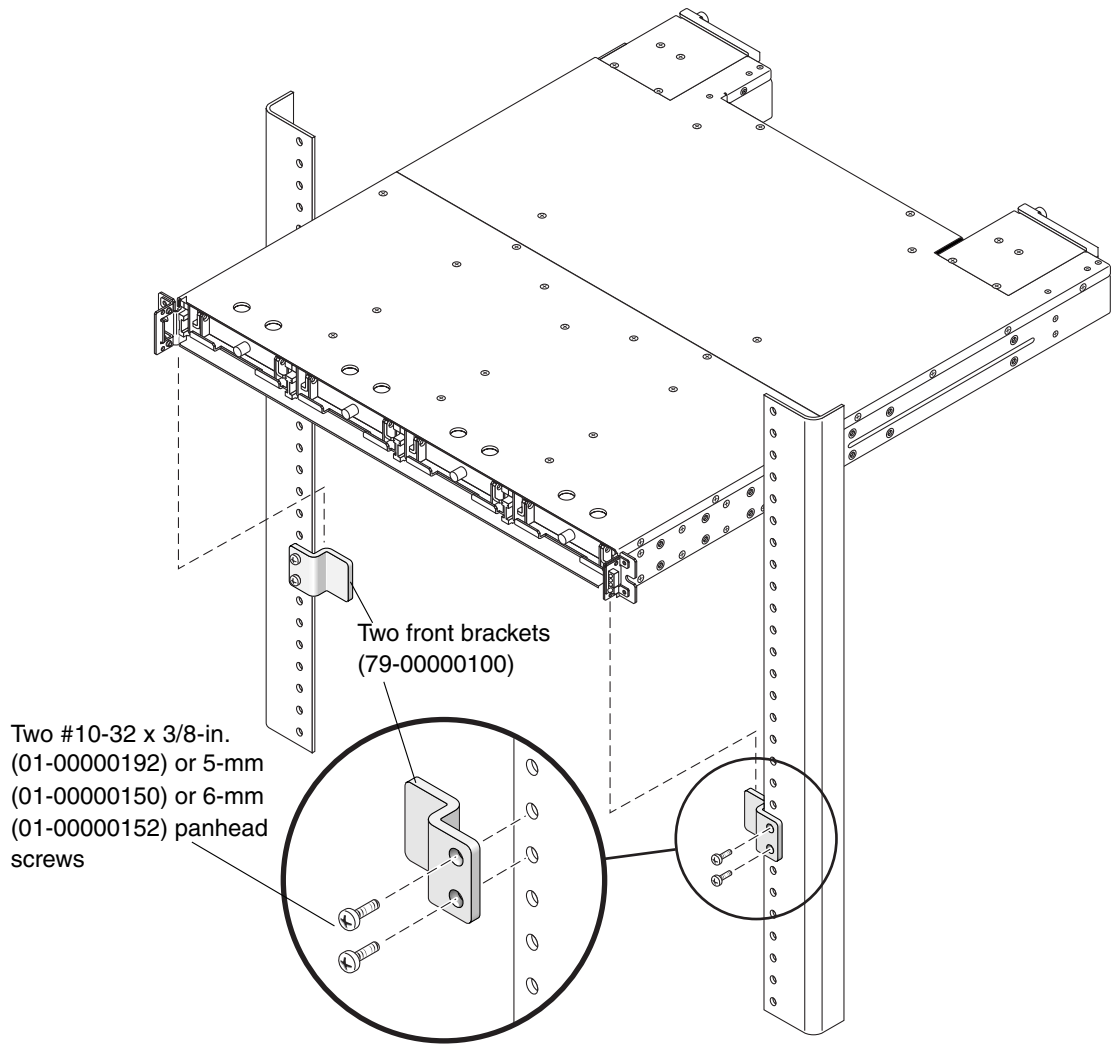

FIGURE 2-8 Front Bracket Position on the Rack Face

4. Remove the bezel (the front faceplate) and the two plastic ear caps from the front of the chassis.



Caution – The plastic ear covers are snap-on parts that require some care when you remove them. Remove the right plastic ear caps carefully to avoid breaking the push button reset switch that is directly behind the ear cap.

To remove a plastic ear cap (both caps are removed the same way):

- a. Grasp both sides of the cap.
- b. With minimal force, pull the cap straight out from the array until it disengages.

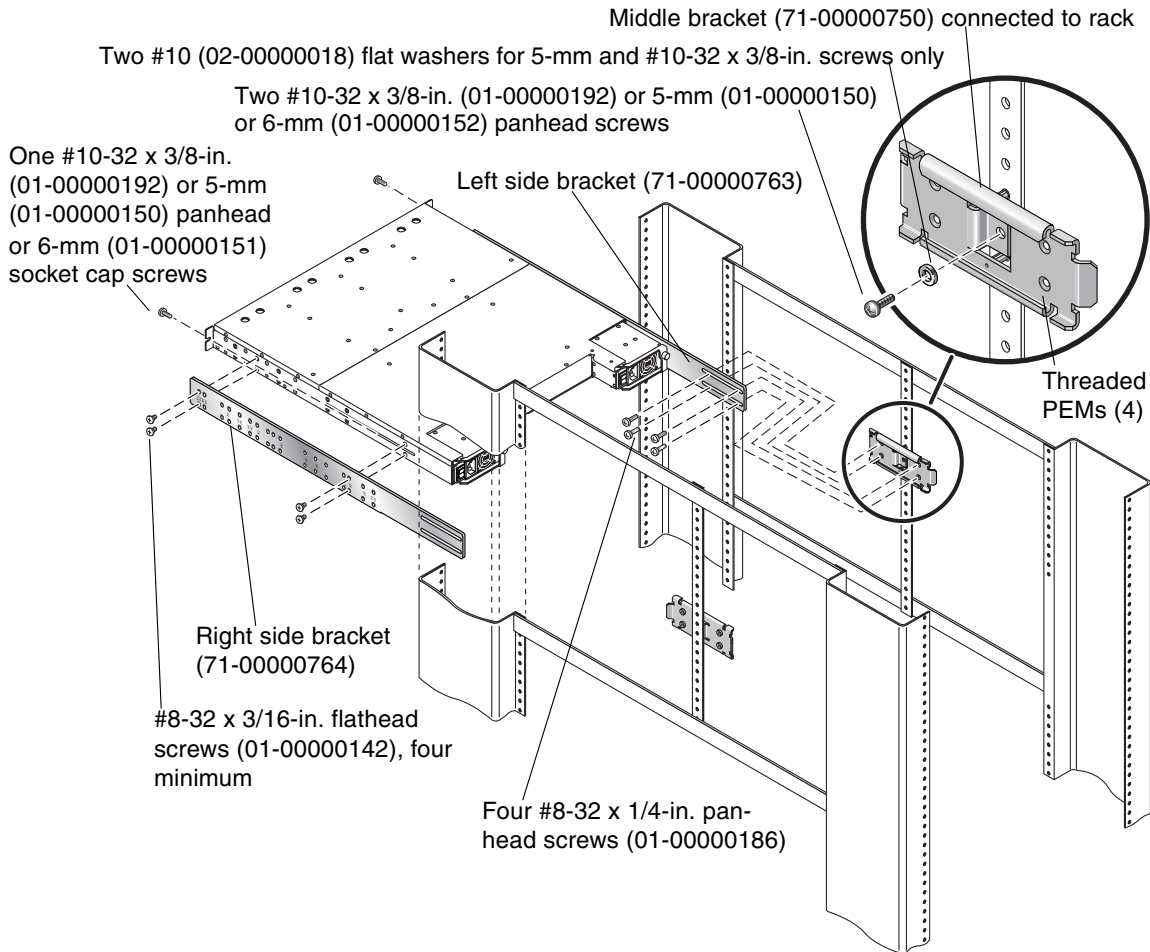

FIGURE 2-9 Cabinet Rackmount with Middle Brackets

Note – Alternate screws can be used with the appropriate racks: 5-mm panhead screws (front and back), or 6-mm socket cap screws (front) and 6-mm panhead screws (back).

5. Attach the side brackets to the left and right sides of the chassis.

Attach up to eight #8-32 x 3/16-inch flathead machine screws (01-00000142) on each side to allow some adjustment to the placement. Make sure you use at least four screws.

Left bracket (71-00000763), inside view (see other side of bracket for alignment marks)



Right bracket (71-00000764), outside view with alignment marks

FIGURE 2-10 Side Brackets

Note – The right and left side brackets may look identical, but they are slightly different. Each side bracket is clearly stamped with numbers. Position the side brackets with the number side of the bracket facing out and the holes closest to the edge of the bracket mounted to the bottom of the chassis. See [TABLE 2-1](#) for the rack kit contents and part numbers.

a. Use the alignment marks (depth in inches) stamped into the side brackets to position the brackets and screws.

There are markings for several depths: 24, 24.5, 26, 27, 28, 30, 32, 34, and 36 inches.

Determine the depth you require, and align the last alignment mark on the side bracket with the last mounting holes on the chassis.

Make sure the alignment mark corresponding to the depth you want lines up with the top and bottom threaded holes on the side of the chassis closest to the rear.

b. Insert the first two screws on each side through the side bracket slots above and below the appropriate alignment mark (24, 24.5, 26, 27, 28, 30, 32, 34, or 36) and into the last pair of rear threaded holes in the chassis.

In [FIGURE 2-11](#) the alignment mark is positioned above and below the last pair of rear threaded holes. This positions the array for a 24.5-inch deep center rail for mounting the middle bracket.

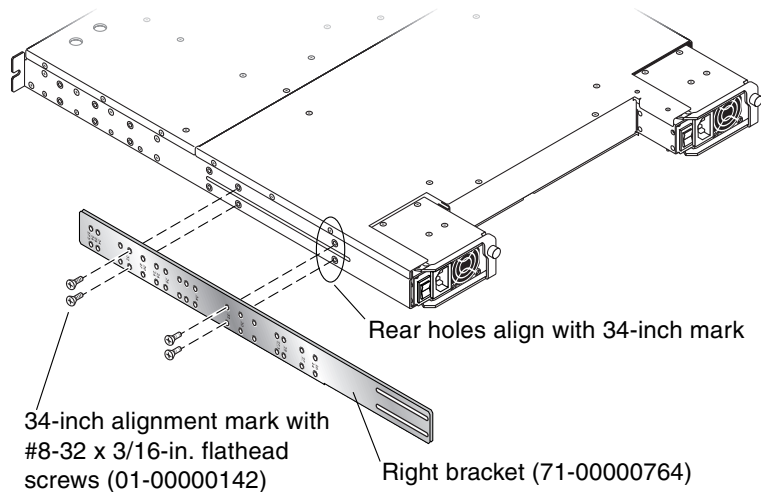

FIGURE 2-11 Aligning a Side Bracket With the Rear Threaded Holes on the Side of the Array

- c. Insert up to six other screws through the side bracket slots into the other threaded holes in the chassis.
6. Attach the middle brackets to the rack center posts using one screw per post. (See [FIGURE 2-9](#)).
 - a. Use one of the following screws:
 - #10-32 x 3/8-inch panhead screws (01-00000192) with one #10 flat washer (02-00000018)
or
 - 5-mm panhead screws (01-00000150) with one #10 flat washer (02-00000018)
or
 - 6-mm panhead screws (01-00000152) (no washer required)

Note – You will have unused screws left in your rackmount kit. This does not indicate a problem with your installation. Several types of screws are included for different rack configurations, and extra screws are provided in case any are misplaced.

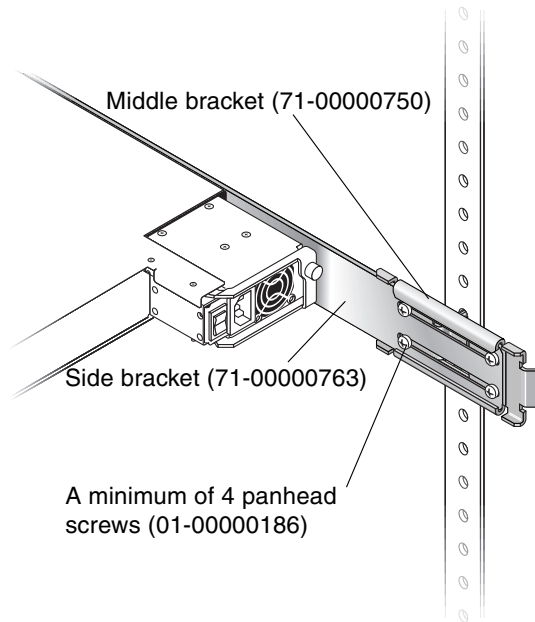

FIGURE 2-12 Middle and Side Brackets Assembled

7. **Lift the chassis and slide the side brackets into the middle brackets, which are attached to the center posts.**

Adjust the depth of these brackets so that the slotted cutouts on the *side brackets* align with the four PEM nuts in the *middle brackets*.

8. **Attach each side bracket to a middle bracket** (see [FIGURE 2-12](#)):

To connect the middle brackets and side brackets of a 24-inch to 36-inch deep rack, use a minimum of four screws each and up to a total of four #8-32 x 1/4-inch panhead screws (01-00000186).

9. **Attach and secure the array's front mounting ears with two appropriate screws (one screw into each ear):**

- Two #10-32 x 3/8-inch panhead screws (01-00000192)
or
- Two 5-mm panhead screws (01-00000150)
or
- Two 6-mm socket cap screws (01-00000151)

Note – You will have unused screws left in your rackmount kit. This does not indicate a problem with your installation. Several types of screws are included for different rack configurations, and extra screws are provided in case any are misplaced.

10. Remount all drives and power/fan modules into the array.
11. If you mounted the unit using the optional front support brackets, remove them from the rack face using a standard screwdriver.
12. Reattach the two plastic ear caps and the bezel onto the front of the chassis.

Each plastic cap is replaced the same way, but be sure the cap with the LED labels on the right ear.

 - a. Align the inside round notches of the cap with the round cylindrical posts (ball studs) on the ear.
 - b. Push the top and bottom of the ear cap onto the ear, pressing in toward the center of the array.
 - c. Continue pushing the top and bottom of the ear cap onto the ear until the ear cap snaps in flush.

Do not use force when placing a cap on an ear.



Caution – Be careful to avoid “wedging” the reset button below the LEDs on the right ear when you replace the plastic cap over it.

- d. Insert the bezel swing arms into the chassis ear holes.
 - e. Lift the bezel into position and press it onto the front of the chassis until it is flush with the front.
 - f. Use the key to lock both bezel locks.
13. Connect power cables to the chassis, power on, and check for proper operation of the LEDs.

For details on powering on and checking LEDs, see [Chapter 4](#).

Telco Rackmounting

This section provides the procedures for mounting a Sun StorEdge 3000 Family 1U array using Telco hardware.

The topics covered are:

- [Section 3.1, “Flushmount Configuration” on page 3-2](#)
- [Section 3.2, “Center-of-Gravity Configuration” on page 3-7](#)

The following tools are used to complete these procedures:

- Medium Phillips screwdriver
- Allen wrench (provided; used with 6mm screws and #12-24 x 3/8-inch socket head screws)



Caution – Do not use any power tools with any procedures. Power tools can strip or damage connections.

3.1 Flushmount Configuration

Before mounting the array into a 19-inch cabinet, check the following parts list and then refer to [FIGURE 3-1](#) during installation.

The following table lists the major components and fasteners required to assemble the Telco 19-inch wide flushmount racks.

Note – It is possible for customer-supplied racks to have several sizes of threaded holes. Rackmount kits have several sizes of panhead screws and sockethead screws in order to fit these various racks. Sockethead screws are supplied for the front mounting ears when the diameter of the screw is too large for panhead screws to fit.

Note – When you finish the installation, you will have unused screws left in your rackmount kit. This does not indicate a problem with your installation. Several types of screws are included for different rack configurations, and extra screws are provided in case any are misplaced.

TABLE 3-1 XTA-3000-1URK-19FZ 1U, Telco Flushmount Kit (594-2313-01)

Major Component			Fasteners		
Qty.	Part Number	Description	Qty.	Part Number	Description
1	71-00000708	bracket, rear left, Telco	12	01-00000186	screws, #8-32 x 1/4 in. panhead, maximum torque: 18-in-pounds
1	71-00000709	bracket, rear right, Telco	8	01-00000192	screws, #10-32 x 3/8 in. panhead, maximum torque: 24-in-pounds
			3	01-00000151	screws, 6-mm socket cap, maximum torque: 24-in-pounds
			4	01-00000193	screws, #12-24 x 3/8 in. socket cap, maximum torque: 30-in-pounds
			4	01-00000190	screws, #12-24 x 3/8 in. panhead, maximum torque: 24-in-pounds
			6	01-00000152	screws, 6-mm panhead, maximum torque: 24-in-pounds
			8	01-00000150	screws, 5-mm panhead, maximum torque: 20-in-pounds
			8	01-00000191	screws, #10-24 x 3/8 in. panhead, maximum torque: 24-in-pounds
			12	02-00000019	washers, #8, flat
			6	02-00000018	washers, #10, flat
1	09-00000064	Allen wrench 5mm, for 6mm socket cap screws			
1	09-00000063	Allen wrench 5/32, for #12-24 socket cap screws.			

Perform the following installation steps for a Telco flushmount rack configuration (see [FIGURE 3-1](#)).

1. Determine the position at which the array will be installed.

Install the first array at the *bottom* of the rack, and install each subsequent chassis above the one below it.

2. Before rackmounting, be sure to check your site location and confirm that you have cables with adequate lengths to connect to servers and to power outlets.

3. Remove bezel (front faceplate) and two plastic ear caps from the front of the chassis.



Caution – The plastic ear covers are snap-on parts that require some care when removing them. Remove the right plastic ear caps carefully to avoid breaking the push button reset switch that is directly behind the ear cap.

To remove a plastic ear cap (both caps are removed the same way):

- a. **Grasp both sides of the cap.**
- b. **With minimal force, pull the cap straight out from the array until it disengages.**

Note – Keep all hardware items in plastic bags until you are ready to use them. This will enable you to correctly identify the screws and avoid confusion.

4. While supporting the chassis, attach the unit to the Telco rack, using two mounting screws through the chassis ears.

Use the appropriate type of screws:

- #10-32 x 3/8-inch panhead screws (01-00000192)
or
- #10-24 x 3/8-inch panhead screws (01-00000191)
or
- 5-mm panhead screws (01-00000150)
or
- #12-24 x 3/8-inch socket cap screws (01-00000193)
or
- 6-mm socket cap screws (01-00000151)

5. Attach the rear brackets to the left and right sides of the chassis. Use four #8-32 x 1/4-inch panhead machine screws (01-000000186) with #8 washers (02-00000019) per bracket.

Use the appropriate type of screws for the posts:

- #10-32 x 3/8-inch panhead screws (01-00000192) with #10 washers (02-00000018)
or
- #10-24 x 3/8-inch panhead screws (01-00000191) with #10 washers (02-00000018)
or
- 5-mm panhead screws (01-00000150) with #10 washers (02-00000018)
or
- #12-24 x 3/8-inch panhead screws (01-00000190)
or
- 6-mm panhead screws (01-00000152)

6. Reinstall all drive modules and power/fan modules into the array if they were removed.

7. Reattach the two plastic ear caps and the bezel onto the front of the chassis.

Each plastic cap is replaced the same way, but be sure the cap with the LED labels on the right ear.

- a. **Align the inside round notches of the cap with the round cylindrical posts (ball studs) on the ear.**
- b. **Push the top and bottom of the ear cap onto the ear, pressing in toward the center of the array.**
- c. **Continue pushing the top and bottom of the ear cap onto the ear until the ear cap snaps in flush.**

Do not use force when placing a cap on an ear.



Caution – Be careful to avoid “wedging” the reset button below the LEDs on the right ear when you replace the plastic cap over it.

- d. **Insert the bezel swing arms into the chassis ear holes.**
 - e. **Lift the bezel into position and press it onto the front of the chassis until it is flush with the front.**
 - f. **Use the key to lock both bezel locks.**
- 8. Connect the power cables to the chassis, power on, and check for proper operation of the LEDs.**

For details on powering on and checking LEDs, see [Chapter 4](#).

Refer to the *Sun StorEdge 3000 Family Installation, Operation, and Service Manual* to see more information about cable connections and LED functionality.

Note – Not all racks allow mountings in the location shown in the following figure.

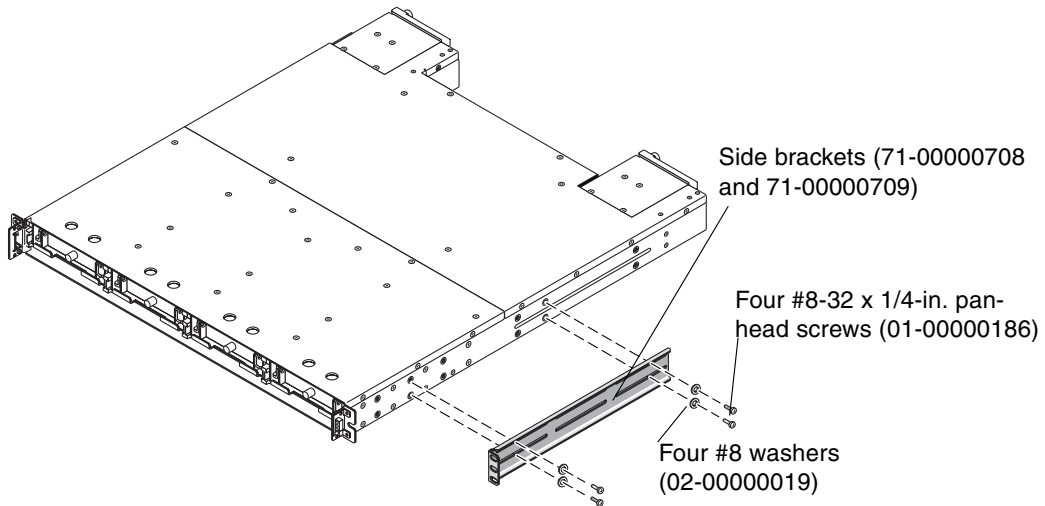
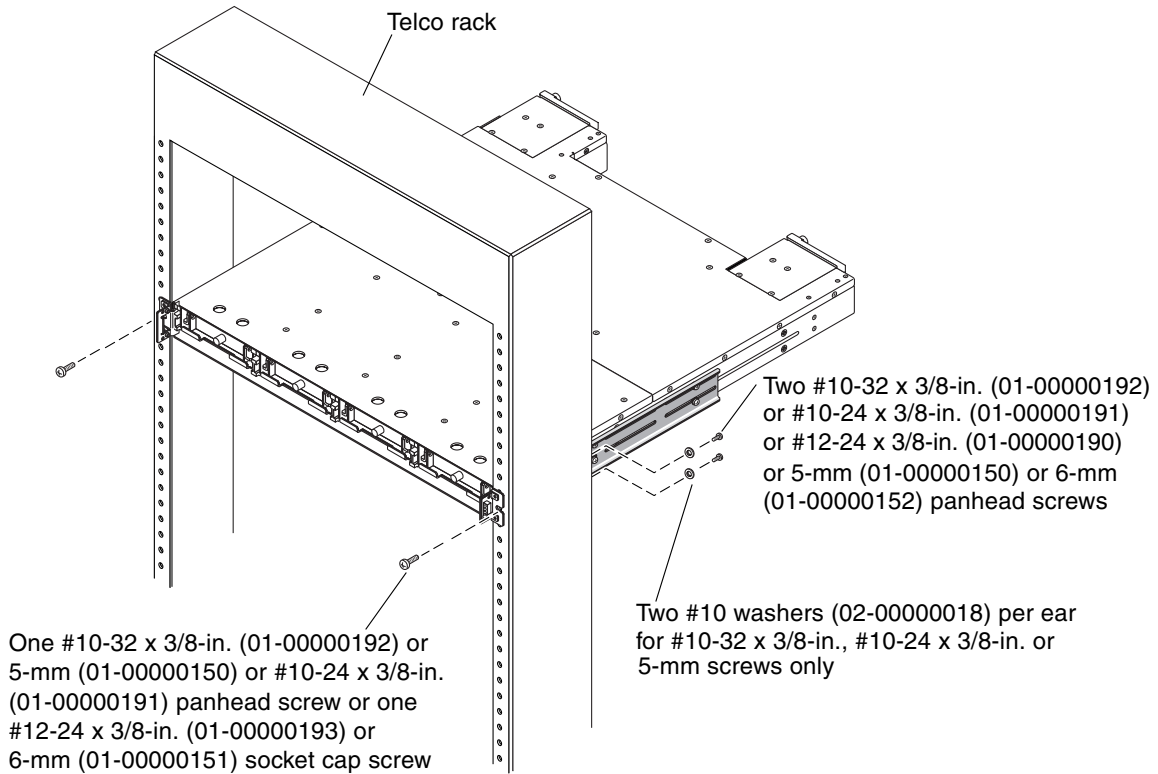

FIGURE 3-1 Flushmount Assembly Example

3.2 Center-of-Gravity Configuration

The following table lists the major components and fasteners required to assemble the Telco 19-inch wide center-of-gravity rack.

Note – It is possible for customer-supplied racks to have several sizes of threaded holes. Rackmount kits have several sizes of panhead screws and sockethead screws in order to fit these various racks. Sockethead screws are supplied for the front mounting ears when the diameter of the screw is too large for panhead screws to fit.

Note – When you finish the installation, you will have unused screws left in your rackmount kit. This does not indicate a problem with your installation. Several types of screws are included for different rack configurations, and extra screws are provided in case any are misplaced.

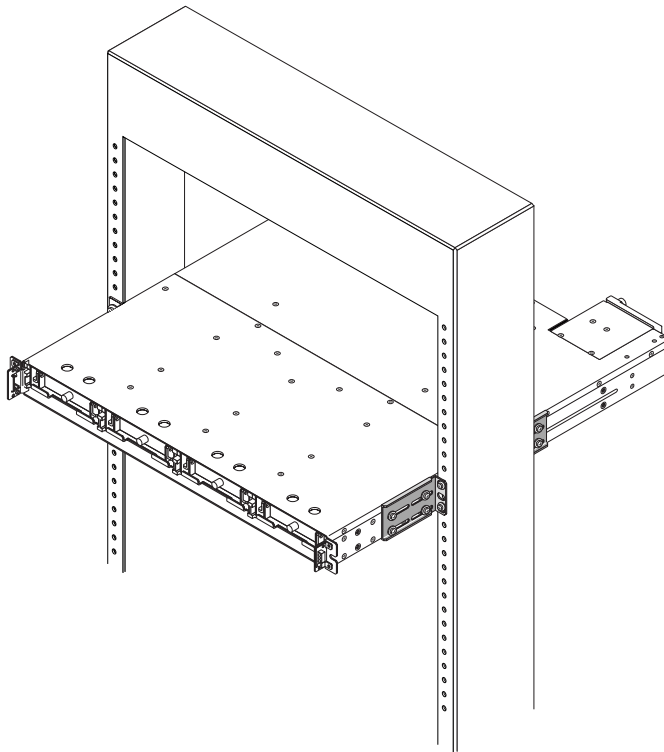

FIGURE 3-2 Rackmounted Telco Array With Chassis Ears and Bezel Removed

TABLE 3-2 XTA-3000-1URK-19CZ 1U, Telco Center-of-Gravity Rackmount Kit (594-2314-01)

Major Components			Fasteners		
Qty.	Part Number	Description	Qty.	Part Number	Description
2	71-00000710	brackets, left rack, Telco	20	01-00000186	screws, #8-32 x 1/4 in. panhead, maximum torque: 18-in-pounds
2	71-00000711	brackets, right rack, Telco	10	01-00000192	screws, #10-32 x 3/8 in. panhead, maximum torque: 24-in-pounds
			10	01-00000152	screws, 6-mm panhead, maximum torque: 24-in-pounds
			10	01-00000150	screws, 5-mm panhead, maximum torque: 20-in-pounds
			10	01-00000191	screws, #10-24 x 3/8 in. panhead, maximum torque: 24-in-pounds
			10	01-00000190	screws, #12-24 x 3/8 in. panhead, maximum torque: 30-in-pounds
			10	02-00000018	washers, #10, flat
			20	02-00000019	washers, #8

Perform the following installation steps for a Telco center-of-gravity rack configuration (see [FIGURE 3-3](#)).

1. Determine the position at which the array will be installed.

Install the first array at the *bottom* of the rack, and install each subsequent chassis above the one below it.

2. Before rackmounting, be sure to check your site location and confirm that you have cables with adequate lengths to connect to servers and to power outlets.

Note – Keep all hardware items in plastic bags until you are ready to use them. This will enable you to correctly identify the screw sizes and avoid confusion.

3. Remove the bezel (front faceplate) and two plastic ear caps from the front of the chassis.



Caution – The plastic ear covers are snap-on parts that require some care when removing them. Remove the right plastic ear caps carefully to avoid breaking the push button reset switch that is directly behind the ear cap.

To remove a plastic ear cap (both caps are removed the same way):

- a. Grasp both sides of the cap.
 - b. With minimal force, pull the cap straight out from the array until it disengages.
4. Attach the two side brackets to each side of the chassis:

Allow for the depth of the rack, and allow for the distance you want the chassis to extend forward in the rack. Attach the front brackets first.

Use up to six #8-32 x 1/4-inch panhead machine screws (01-00000186) with #8 washers (02-00000019) for each **side bracket**, using the mounting holes available. (Use four screws as a minimum.) Then mount the side brackets to the Telco rack using step 5.

5. Attach the chassis to the Telco rack, by inserting eight or more screws through the mounting holes located on both sides of the brackets and into the frame. (See [FIGURE 3-3](#).)

Use the appropriate type of screws for the ports:

- #10-32 x 3/8-inch panhead screws (01-00000192) with #10 washers (02-00000018)
or
- #10-24 x 3/8-inch panhead screws (01-00000191) with #10 washers (02-00000018)
or
- 5-mm panhead screws (01-00000150) with #10 washers (02-00000018)
or
- 6-mm panhead screws (01-00000152)
or
- #12-24 x 3/8-inch panhead screws (01-00000190)

Next, use four #8-32 x 1/4-inch panhead screws (01-00000186) with #8 washers (02-00000019) for each **side bracket**.

6. Reinstall all drive modules and power/fan modules into the array if they were removed.

7. Reattach the two plastic ear caps and the bezel onto the front of the chassis.

Each plastic cap is replaced the same way, but be sure the cap with the LED labels on the right ear.

- a. **Align the inside round notches of the cap with the round cylindrical posts (ball studs) on the ear.**
- b. **Push the top and bottom of the ear cap onto the ear, pressing in toward the center of the array.**
- c. **Continue pushing the top and bottom of the ear cap onto the ear until the ear cap snaps in flush.**

Do not use force when placing a cap on an ear.



Caution – Be careful to avoid “wedging” the reset button below the LEDs on the right ear when you replace the plastic cap over it.

- d. **Insert the bezel swing arms into the chassis ear holes.**
 - e. **Lift the bezel into position and press it onto the front of the chassis until it is flush with the front.**
 - f. **Use the key to lock both bezel locks.**
- 8. Connect power cables to the chassis, power on, and check for proper operation of the LEDs.**

For details on powering on and checking LEDs, see [Chapter 4](#).

Refer to the *Sun StorEdge 3000 Family Installation, Operation, and Service Manual* to see more information about cable connections and LED functionality.

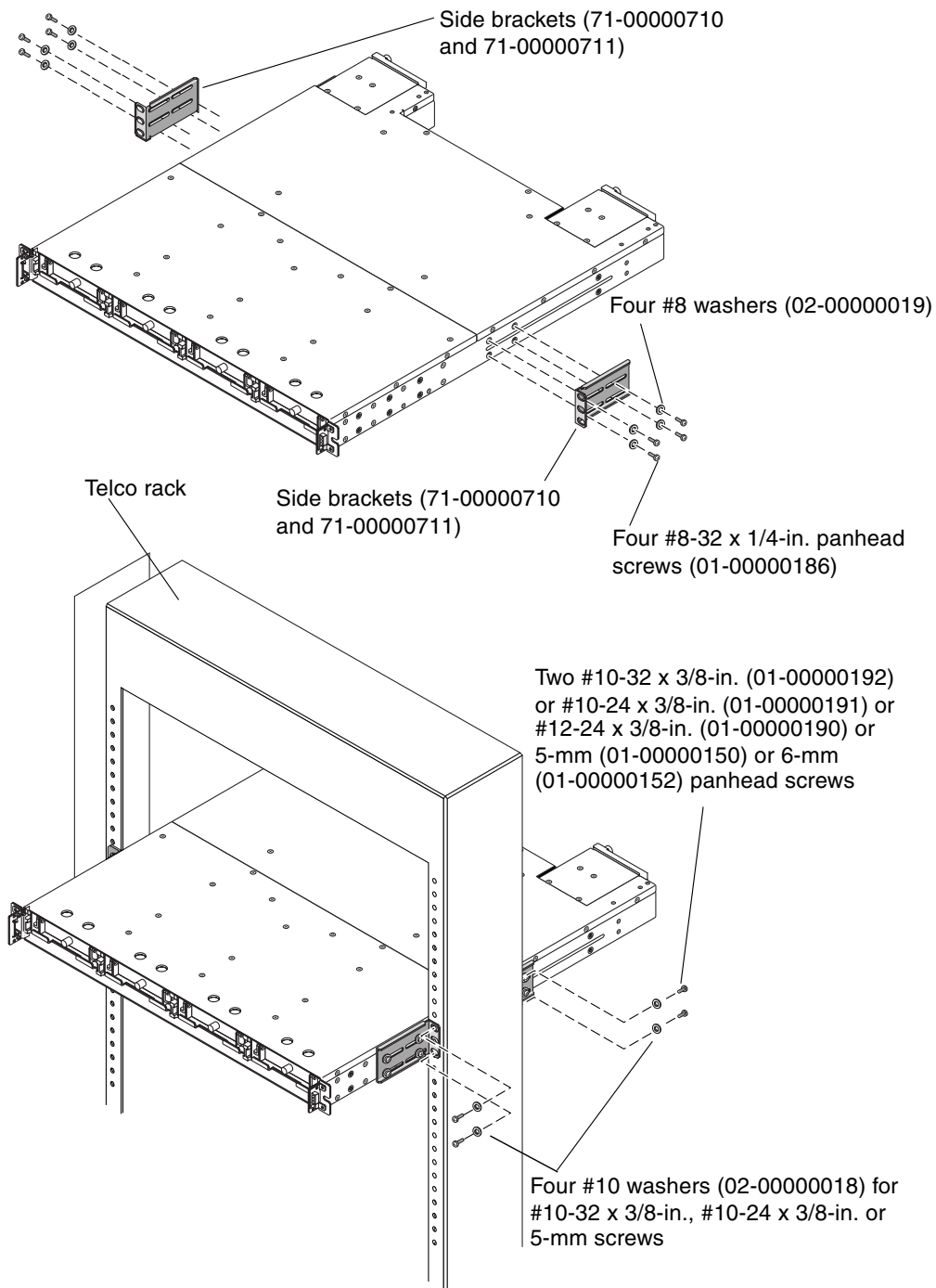

FIGURE 3-3 Center-of-Gravity Assembly

Powering On and Checking LEDs

Perform the initial check of the array according to the following procedure.

1. Connect two AC (or DC) power cables to the power/fan modules on the rear of the array.
2. Power on the array. Make sure all front LEDs turn solid green.

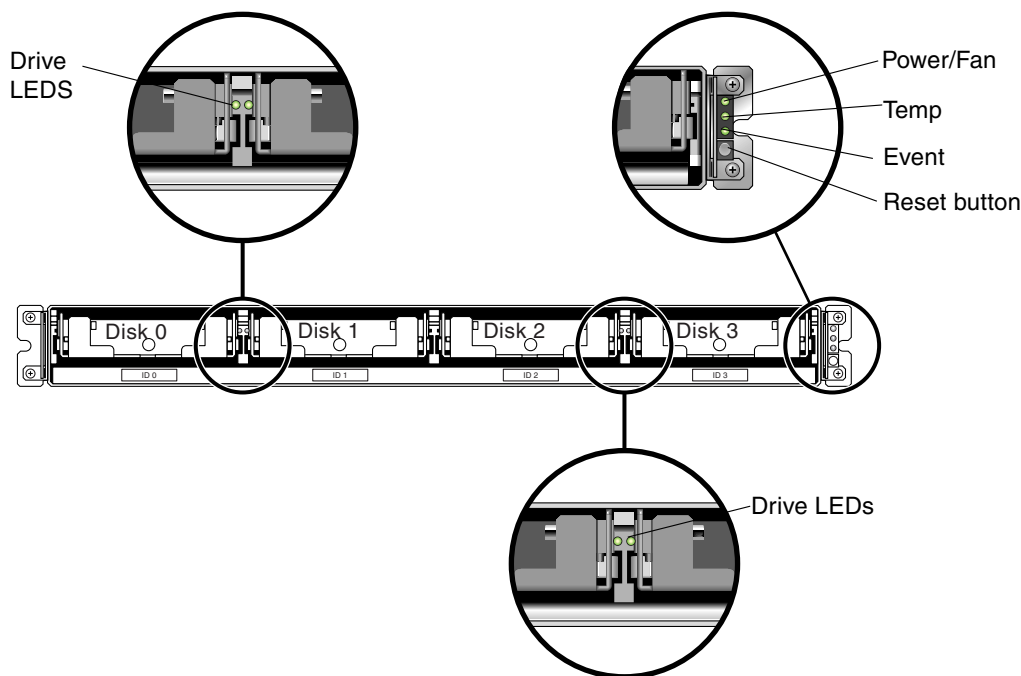

FIGURE 4-1 Front-Panel with LEDs Displayed

Refer to the *Sun StorEdge 3000 Family Installation, Operation, and Service Manual* for your array for more information about LEDs.

