

Sun™ StorEdge™ UniPack User's Guide



THE NETWORK IS THE COMPUTER™

Sun Microsystems Computer Company

A Sun Microsystems, Inc. Business
901 San Antonio Road
Palo Alto, CA 94303-4900 USA
650 960-1300 fax 650 969-9131

Part No.: 805-3941-10
Revision A, February 1998

Copyright 1998 Sun Microsystems, Inc., 901 San Antonio Road • Palo Alto, CA 94303 USA. All rights reserved.

This product or document is protected by copyright and distributed under licenses restricting its use, copying, distribution, and decompilation. No part of this product or document may be reproduced in any form by any means without prior written authorization of Sun and its licensors, if any. Third-party software, including font technology, is copyrighted and licensed from Sun suppliers.

Parts of the product may be derived from Berkeley BSD systems, licensed from the University of California. UNIX is a registered trademark in the U.S. and other countries, exclusively licensed through X/Open Company, Ltd.

Sun, Sun Microsystems, the Sun logo, AnswerBook, SunDocs, StorEdge, and Solaris re trademarks, registered trademarks, or service marks of Sun Microsystems, Inc. in the U.S. and other countries. All SPARC trademarks are used under license and are trademarks or registered trademarks of SPARC International, Inc. in the U.S. and other countries. Products bearing SPARC trademarks are based upon an architecture developed by Sun Microsystems, Inc.

The OPEN LOOK and Sun™ Graphical User Interface was developed by Sun Microsystems, Inc. for its users and licensees. Sun acknowledges the pioneering efforts of Xerox in researching and developing the concept of visual or graphical user interfaces for the computer industry. Sun holds a non-exclusive license from Xerox to the Xerox Graphical User Interface, which license also covers Sun's licensees who implement OPEN LOOK GUIs and otherwise comply with Sun's written license agreements.

RESTRICTED RIGHTS: Use, duplication, or disclosure by the U.S. Government is subject to restrictions of FAR 52.227-14(g)(2)(6/87) and FAR 52.227-19(6/87), or DFAR 252.227-7015(b)(6/95) and DFAR 227.7202-3(a).

DOCUMENTATION IS PROVIDED "AS IS" AND ALL EXPRESS OR IMPLIED CONDITIONS, REPRESENTATIONS AND WARRANTIES, INCLUDING ANY IMPLIED WARRANTY OF MERCHANTABILITY, FITNESS FOR A PARTICULAR PURPOSE OR NON-INFRINGEMENT, ARE DISCLAIMED, EXCEPT TO THE EXTENT THAT SUCH DISCLAIMERS ARE HELD TO BE LEGALLY INVALID.

Copyright 1998 Sun Microsystems, Inc., 901 San Antonio Road • Palo Alto, CA 94303 Etats-Unis. Tous droits réservés.

Ce produit ou document est protégé par un copyright et distribué avec des licences qui en restreignent l'utilisation, la copie, la distribution, et la décompilation. Aucune partie de ce produit ou document ne peut être reproduite sous aucune forme, par quelque moyen que ce soit, sans l'autorisation préalable et écrite de Sun et de ses bailleurs de licence, s'il y en a. Le logiciel détenu par des tiers, et qui comprend la technologie relative aux polices de caractères, est protégé par un copyright et licencié par des fournisseurs de Sun.

Des parties de ce produit pourront être dérivées des systèmes Berkeley BSD licenciés par l'Université de Californie. UNIX est une marque déposée aux Etats-Unis et dans d'autres pays et licenciée exclusivement par X/Open Company, Ltd.

Sun, Sun Microsystems, le logo Sun, AnswerBook, StorEdge, SunDocs, et Solaris sont des marques de fabrique ou des marques déposées, ou marques de service, de Sun Microsystems, Inc. aux Etats-Unis et dans d'autres pays. Toutes les marques SPARC sont utilisées sous licence et sont des marques de fabrique ou des marques déposées de SPARC International, Inc. aux Etats-Unis et dans d'autres pays. Les produits portant les marques SPARC sont basés sur une architecture développée par Sun Microsystems, Inc.

L'interface d'utilisation graphique OPEN LOOK et Sun™ a été développée par Sun Microsystems, Inc. pour ses utilisateurs et licenciés. Sun reconnaît les efforts de pionniers de Xerox pour la recherche et le développement du concept des interfaces d'utilisation visuelle ou graphique pour l'industrie de l'informatique. Sun détient une licence non exclusive de Xerox sur l'interface d'utilisation graphique Xerox, cette licence couvrant également les licenciés de Sun qui mettent en place l'interface d'utilisation graphique OPEN LOOK et qui en outre se conforment aux licences écrites de Sun.

CETTE PUBLICATION EST FOURNIE "EN L'ETAT" ET AUCUNE GARANTIE, EXPRESSE OU IMPLICITE, N'EST ACCORDEE, Y COMPRIS DES GARANTIES CONCERNANT LA VALEUR MARCHANDE, L'APTITUDE DE LA PUBLICATION A REpondre A UNE UTILISATION PARTICULIERE, OU LE FAIT QU'ELLE NE SOIT PAS CONTREFAISANTE DE PRODUIT DE TIERS. CE DENI DE GARANTIE NE S'APPLIQUERAIT PAS, DANS LA MESURE OU IL SERAIT TENU JURIDIQUEMENT NUL ET NON AVENU.



Adobe PostScript

Regulatory Compliance Statements

Your Sun product is marked to indicate its compliance class:

- Federal Communications Commission (FCC) — USA
- Department of Communications (DOC) — Canada
- Voluntary Control Council for Interference (VCCI) — Japan

Please read the appropriate section that corresponds to the marking on your Sun product before attempting to install the product.

FCC Class A Notice

This device complies with Part 15 of the FCC Rules. Operation is subject to the following two conditions:

1. This device may not cause harmful interference.
2. This device must accept any interference received, including interference that may cause undesired operation.

Note: This equipment has been tested and found to comply with the limits for a Class A digital device, pursuant to Part 15 of the FCC Rules. These limits are designed to provide reasonable protection against harmful interference when the equipment is operated in a commercial environment. This equipment generates, uses and can radiate radio frequency energy and, if not installed and used in accordance with the instruction manual, may cause harmful interference to radio communications. Operation of this equipment in a residential area is likely to cause harmful interference in which case the user will be required to correct the interference at his own expense.

Shielded Cables: Connections between the workstation and peripherals must be made using shielded cables in order to maintain compliance with FCC radio frequency emission limits. Networking connections can be made using unshielded twisted-pair (UTP) cables.

Modifications: Any modifications made to this device that are not approved by Sun Microsystems, Inc. may void the authority granted to the user by the FCC to operate this equipment.

FCC Class B Notice

This device complies with Part 15 of the FCC Rules. Operation is subject to the following two conditions:

1. This device may not cause harmful interference.
2. This device must accept any interference received, including interference that may cause undesired operation.

Note: This equipment has been tested and found to comply with the limits for a Class B digital device, pursuant to Part 15 of the FCC Rules. These limits are designed to provide reasonable protection against harmful interference in a residential installation. This equipment generates, uses and can radiate radio frequency energy and, if not installed and used in accordance with the instructions, may cause harmful interference to radio communications. However, there is no guarantee that interference will not occur in a particular installation. If this equipment does cause harmful interference to radio or television reception, which can be determined by turning the equipment off and on, the user is encouraged to try to correct the interference by one or more of the following measures:

- Reorient or relocate the receiving antenna.
- Increase the separation between the equipment and receiver.
- Connect the equipment into an outlet on a circuit different from that to which the receiver is connected.
- Consult the dealer or an experienced radio/television technician for help.

Shielded Cables: Connections between the workstation and peripherals must be made using shielded cables in order to maintain compliance with FCC radio frequency emission limits. Networking connections can be made using unshielded twisted pair (UTP) cables.

Modifications: Any modifications made to this device that are not approved by Sun Microsystems, Inc. may void the authority granted to the user by the FCC to operate this equipment.

DOC Class A Notice - Avis DOC, Classe A

This Class A digital apparatus meets all requirements of the Canadian Interference-Causing Equipment Regulations.
Cet appareil numérique de la classe A respecte toutes les exigences du Règlement sur le matériel brouilleur du Canada.

DOC Class B Notice - Avis DOC, Classe B

This Class B digital apparatus meets all requirements of the Canadian Interference-Causing Equipment Regulations.
Cet appareil numérique de la classe B respecte toutes les exigences du Règlement sur le matériel brouilleur du Canada.

VCCI 基準について

第一種VCCI基準について

第一種VCCIの表示があるワークステーションおよびオプション製品は、第一種情報装置です。これらの製品には、下記の項目が該当します。

この装置は、第一種情報装置(商工業地域において使用されるべき情報装置)で商工業地域での電波障害防止を目的とした情報処理装置等電波障害自主規制協議会(VCCI)基準に適合しております。したがって、本製品を、住宅地域または住宅地域に隣接した地域でご使用になりますと、ラジオ、テレビジョン受信機等に受信障害を与えることがあります。

取り扱い説明書に従って正しくお取り扱いください。

第二種VCCI基準について

第二種VCCIの表示  があるワークステーションおよびオプション製品は、第二種情報装置です。これらの製品には、下記の項目が該当します。

この装置は、第二種情報装置(住宅地域または住宅地域に隣接した地域において使用されるべき情報装置)で住宅地域での電波障害防止を目的とした情報処理装置等電波障害自主規制協議会(VCCI)基準に適合しております。しかし、本製品を、ラジオ、テレビジョン受信機に近接してご使用になりますと、受信障害の原因となることがあります。

取り扱い説明書に従って正しくお取り扱いください。

Declaration of Conformity

Model Number: 611
Product Name: Sun StorEdge UniPack Family

EMC

USA—FCC Class B

This equipment complies with Part 15 of the FCC Rules. Operation is subject to the following two conditions:

- 1) This equipment may not cause harmful interference.
- 2) This equipment must accept any interference that may cause undesired operation.

European Union

This equipment complies with the following requirements of the EMC Directive 89/336/EEC:

EN55022 / CISPR22 (1985)	Class B
EN50082-1 IEC801-2 (1991)	4 kV (Direct)8 kV (Air)
IEC801-3 (1984)	3 V/m
IEC801-4 (1988)	1.0 kV Power Lines, 0.5 kV Signal Lines
EN61000-3-2/IEC1000-3-2(1994)	Pass

Safety

This equipment complies with the following requirements of Low Voltage Directive 73/23/EEC:

EC Type Examination Certificates:

EN60950/IEC950 (1993)
TUV Rheinland Certificate # S9577165
EN60950 w/ Nordic Deviations

CB Scheme Certificate # UL520-138989/USA

Supplementary Information:

This product was tested and complies with all the requirements for the CE Mark when connected to a Sun workstation or server.

/ S /

Dennis P. Symanski DATE
Manager, Product Compliance

/ S /

John Shades DATE
Quality Assurance Manager

Sun Microsystems, Inc.
901 San Antonio Road, M/S UMPK15-102
Palo Alto, CA 94303, USA
Tel: 650-786-3255
Fax: 650-786-3723

Sun Microsystems Scotland, Limited
Springfield, Linlithgow
West Lothian, EH49 7LR
Scotland, United Kingdom
Tel: 0506 670000
Fax: 0506 760011

Safety Agency Compliance Statements

Read this section before beginning any procedure. The following text provides safety precautions to follow when installing a Sun Microsystems product.

Safety Precautions

For your protection, observe the following safety precautions when setting up your equipment:

- Follow all cautions and instructions marked on the equipment.
- Ensure that the voltage and frequency of your power source match the voltage and frequency inscribed on the equipment's electrical rating label.
- Never push objects of any kind through openings in the equipment. Dangerous voltages may be present. Conductive foreign objects could produce a short circuit that could cause fire, electric shock, or damage to your equipment.

Symbols

The following symbols may appear in this book:



Caution – There is risk of personal injury and equipment damage. Follow the instructions.



Caution – Hot surface. Avoid contact. Surfaces are hot and may cause personal injury if touched.



Caution – Hazardous voltages are present. To reduce the risk of electric shock and danger to personal health, follow the instructions.



On – Applies AC power to the system.

Depending on the type of power switch your device has, one of the following symbols may be used:



Off – Removes AC power from the system.



Standby – The On/Standby switch is in the *standby* position.

Modifications to Equipment

Do not make mechanical or electrical modifications to the equipment. Sun Microsystems is not responsible for regulatory compliance of a modified Sun product.

Placement of a Sun Product



Caution – Do not block or cover the openings of your Sun product. Never place a Sun product near a radiator or heat register. Failure to follow these guidelines can cause overheating and affect the reliability of your Sun product.

SELV Compliance

Safety status of I/O connections comply to SELV requirements.

Power Cord Connection



Caution – Sun products are designed to work with single-phase power systems having a grounded neutral conductor. To reduce the risk of electric shock, do not plug Sun products into any other type of power system. Contact your facilities manager or a qualified electrician if you are not sure what type of power is supplied to your building.



Caution – Not all power cords have the same current ratings. Household extension cords do not have overload protection and are not meant for use with computer systems. Do not use household extension cords with your Sun product.



Caution – Your Sun product is shipped with a grounding type (three-wire) power cord. To reduce the risk of electric shock, always plug the cord into a grounded power outlet.

The following caution applies only to devices with a **Standby** power switch:



Caution – The power switch of this product functions as a standby type device only. The power cord serves as the primary disconnect device for the system. Be sure to plug the power cord into a grounded power outlet that is nearby the system and is readily accessible. Do not connect the power cord when the power supply has been removed from the system chassis.

Lithium Battery



Caution – On Sun CPU boards, there is a lithium battery molded into the real-time clock, SGS No. MK48T59Y, MK48TXXB-XX, MK48T18-XXXPCZ, M48T59W-XXXPCZ, or MK48T08. Batteries are not customer replaceable parts. They may explode if mishandled. Do not dispose of the battery in fire. Do not disassemble it or attempt to recharge it.

System Unit Cover

You must remove the cover of your Sun computer system unit in order to add cards, memory, or internal storage devices. Be sure to replace the top cover before powering up your computer system.



Caution – Do not operate Sun products without the top cover in place. Failure to take this precaution may result in personal injury and system damage.

Laser Compliance Notice

Sun products that use laser technology comply with Class 1 laser requirements.

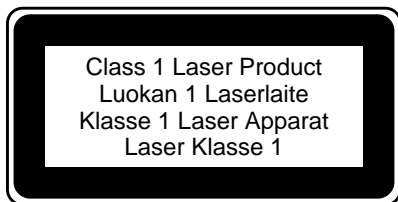

CD-ROM



Caution – Use of controls, adjustments, or the performance of procedures other than those specified herein may result in hazardous radiation exposure.

Einhaltung sicherheitsbehördlicher Vorschriften

Auf dieser Seite werden Sicherheitsrichtlinien beschrieben, die bei der Installation von Sun-Produkten zu beachten sind.

Sicherheitsvorkehrungen

Treffen Sie zu Ihrem eigenen Schutz die folgenden Sicherheitsvorkehrungen, wenn Sie Ihr Gerät installieren:

- Beachten Sie alle auf den Geräten angebrachten Warnhinweise und Anweisungen.

- Vergewissern Sie sich, daß Spannung und Frequenz Ihrer Stromquelle mit der Spannung und Frequenz übereinstimmen, die auf dem Etikett mit den elektrischen Nennwerten des Geräts angegeben sind.
- Stecken Sie auf keinen Fall irgendwelche Gegenstände in Öffnungen in den Geräten. Leitfähige Gegenstände könnten aufgrund der möglicherweise vorliegenden gefährlichen Spannungen einen Kurzschluß verursachen, der einen Brand, Stromschlag oder Geräteschaden herbeiführen kann.

Symbole

Die Symbole in diesem Handbuch haben folgende Bedeutung:



Achtung – Gefahr von Verletzung und Geräteschaden. Befolgen Sie die Anweisungen.



Achtung – Hohe Temperatur. Nicht berühren, da Verletzungsgefahr durch heiße Oberfläche besteht.



Achtung – Gefährliche Spannungen. Anweisungen befolgen, um Stromschläge und Verletzungen zu vermeiden.



Ein – Setzt das System unter Wechselstrom.

Je nach Netzschaltertyp an Ihrem Gerät kann eines der folgenden Symbole benutzt werden:



Aus – Unterbricht die Wechselstromzufuhr zum Gerät.



Wartezustand (Stand-by-Position) - Der Ein-/Wartezustand-Schalter steht auf Wartezustand. Änderungen an Sun-Geräten.

Nehmen Sie keine mechanischen oder elektrischen Änderungen an den Geräten vor. Sun Microsystems, übernimmt bei einem Sun-Produkt, das geändert wurde, keine Verantwortung für die Einhaltung behördlicher Vorschriften

Aufstellung von Sun-Geräten



Achtung – Um den zuverlässigen Betrieb Ihres Sun-Geräts zu gewährleisten und es vor Überhitzung zu schützen, dürfen die Öffnungen im Gerät nicht blockiert oder verdeckt werden. Sun-Produkte sollten niemals in der Nähe von Heizkörpern oder Heizluftklappen aufgestellt werden.

Einhaltung der SELV-Richtlinien

Die Sicherung der I/O-Verbindungen entspricht den Anforderungen der SELV-Spezifikation.

Anschluß des Netzkabels



Achtung – Sun-Produkte sind für den Betrieb an Einphasen-Stromnetzen mit geerdetem Nulleiter vorgesehen. Um die Stromschlaggefahr zu reduzieren, schließen Sie Sun-Produkte nicht an andere Stromquellen an. Ihr Betriebsleiter oder ein qualifizierter Elektriker kann Ihnen die Daten zur Stromversorgung in Ihrem Gebäude geben.



Achtung – Nicht alle Netzkabel haben die gleichen Nennwerte. Herkömmliche, im Haushalt verwendete Verlängerungskabel besitzen keinen Überlastungsschutz und sind daher für Computersysteme nicht geeignet.



Achtung – Ihr Sun-Gerät wird mit einem dreidradigen Netzkabel für geerdete Netzsteckdosen geliefert. Um die Gefahr eines Stromschlags zu reduzieren, schließen Sie das Kabel nur an eine fachgerecht verlegte, geerdete Steckdose an.

Die folgende Warnung gilt nur für Geräte mit Wartezustand-Netzschalter:



Achtung – Der Ein/Aus-Schalter dieses Geräts schaltet nur auf Wartezustand (Stand-By-Modus). Um die Stromzufuhr zum Gerät vollständig zu unterbrechen, müssen Sie das Netzkabel von der Steckdose abziehen. Schließen Sie den Stecker des Netzkabels an eine in der Nähe befindliche, frei zugängliche, geerdete Netzsteckdose an. Schließen Sie das Netzkabel nicht an, wenn das Netzteil aus der Systemeinheit entfernt wurde.

Lithiumbatterie



Achtung – CPU-Karten von Sun verfügen über eine Echtzeituhr mit integrierter Lithiumbatterie (Teile-Nr. MK48T59Y, MK48TXXB-XX, MK48T18-XXXPCZ, M48T59W-XXXPCZ, oder MK48T08). Diese Batterie darf nur von einem qualifizierten Servicetechniker ausgewechselt werden, da sie bei falscher Handhabung explodieren kann. Werfen Sie die Batterie nicht ins Feuer. Versuchen Sie auf keinen Fall, die Batterie auszubauen oder wiederaufzuladen.

Gehäuseabdeckung

Sie müssen die obere Abdeckung Ihres Sun-Systems entfernen, um interne Komponenten wie Karten, Speicherchips oder Massenspeicher hinzuzufügen. Bringen Sie die obere Gehäuseabdeckung wieder an, bevor Sie Ihr System einschalten.



Achtung – Bei Betrieb des Systems ohne obere Abdeckung besteht die Gefahr von Stromschlag und Systemschäden.

Einhaltung der Richtlinien für Laser

Sun-Produkte, die mit Laser-Technologie arbeiten, entsprechen den Anforderungen der Laser Klasse 1.

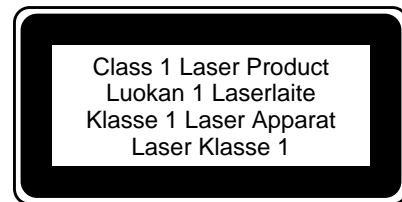

CD-ROM



Warnung – Die Verwendung von anderen Steuerungen und Einstellungen oder die Durchführung von Prozeduren, die von den hier beschriebenen abweichen, können gefährliche Strahlungen zur Folge haben.

Conformité aux normes de sécurité

Ce texte traite des mesures de sécurité qu'il convient de prendre pour l'installation d'un produit Sun Microsystems.

Mesures de sécurité

Pour votre protection, veuillez prendre les précautions suivantes pendant l'installation du matériel :

- Suivre tous les avertissements et toutes les instructions inscrites sur le matériel.
- Vérifier que la tension et la fréquence de la source d'alimentation électrique correspondent à la tension et à la fréquence indiquées sur l'étiquette de classification de l'appareil.
- Ne jamais introduire d'objets quels qu'ils soient dans une des ouvertures de l'appareil. Vous pourriez vous trouver en présence de hautes tensions dangereuses. Tout objet conducteur introduit de la sorte pourrait produire un court-circuit qui entraînerait des flammes, des risques d'électrocution ou des dégâts matériels.

Symboles

Vous trouverez ci-dessous la signification des différents symboles utilisés :



Attention : risques de blessures corporelles et de dégâts matériels. Veuillez suivre les instructions.



Attention : surface à température élevée. Evitez le contact. La température des surfaces est élevée et leur contact peut provoquer des blessures corporelles.



Attention : présence de tensions dangereuses. Pour éviter les risques d'électrocution et de danger pour la santé physique, veuillez suivre les instructions.



MARCHE – Votre système est sous tension (courant alternatif).

Un des symboles suivants sera peut-être utilisé en fonction du type d'interrupteur de votre système:



ARRÊT – Votre système est hors tension (courant alternatif).



VEILLEUSE – L'interrupteur Marche/Veilleuse est en position « Veilleuse ».

Modification du matériel

Ne pas apporter de modification mécanique ou électrique au matériel. Sun Microsystems n'est pas responsable de la conformité réglementaire d'un produit Sun qui a été modifié.

Positionnement d'un produit Sun



Attention : pour assurer le bon fonctionnement de votre produit Sun et pour l'empêcher de surchauffer, il convient de ne pas obstruer ni recouvrir les ouvertures prévues dans l'appareil. Un produit Sun ne doit jamais être placé à proximité d'un radiateur ou d'une source de chaleur.

Conformité SELV

Sécurité : les raccordements E/S sont conformes aux normes SELV.

Connexion du cordon d'alimentation



Attention : les produits Sun sont conçus pour fonctionner avec des alimentations monophasées munies d'un conducteur neutre mis à la terre. Pour écarter les risques d'électrocution, ne pas brancher de produit Sun dans un autre type d'alimentation secteur. En cas de doute quant au type d'alimentation électrique du local, veuillez vous adresser au directeur de l'exploitation ou à un électricien qualifié.



Attention : tous les cordons d'alimentation n'ont pas forcément la même puissance nominale en matière de courant. Les rallonges d'usage domestique n'offrent pas de protection contre les surcharges et ne sont pas prévues pour les systèmes d'ordinateurs. Ne pas utiliser de rallonge d'usage domestique avec votre produit Sun.



Attention : votre produit Sun a été livré équipé d'un cordon d'alimentation à trois fils (avec prise de terre). Pour écarter tout risque d'électrocution, branchez toujours ce cordon dans une prise mise à la terre.

L'avertissement suivant s'applique uniquement aux systèmes équipés d'un interrupteur VEILLEUSE:



Attention : le commutateur d'alimentation de ce produit fonctionne comme un dispositif de mise en veille uniquement. C'est la prise d'alimentation qui sert à mettre le produit hors tension. Veuillez donc à installer le produit à proximité d'une prise murale facilement accessible. Ne connectez pas la prise d'alimentation lorsque le châssis du système n'est plus alimenté.

Batterie au lithium



Attention : sur les cartes CPU Sun, une batterie au lithium (référence MK48T59Y, MK48TXXB-XX, MK48T18-XXXPCZ, M48T59W-XXXPCZ, ou MK48T08.) a été moulée dans l'horloge temps réel SGS. Les batteries ne sont pas des pièces remplaçables par le client. Elles risquent d'exploser en cas de mauvais traitement. Ne pas jeter la batterie au feu. Ne pas la démonter ni tenter de la recharger.

Couvercle

Pour ajouter des cartes, de la mémoire, ou des unités de stockage internes, vous devrez démonter le couvercle de l'unité système Sun. Ne pas oublier de remettre ce couvercle en place avant de mettre le système sous tension.



Attention : il est dangereux de faire fonctionner un produit Sun sans le couvercle en place. Si l'on néglige cette précaution, on encourt des risques de blessures corporelles et de dégâts matériels.

Conformité aux certifications Laser

Les produits Sun qui font appel aux technologies lasers sont conformes aux normes de la classe 1 en la matière.

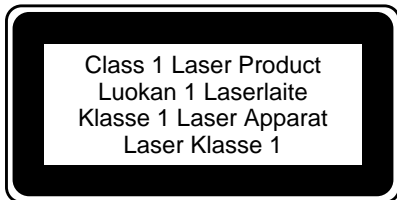

CD-ROM



Attention – L'utilisation de contrôles, de réglages ou de performances de procédures autre que celle spécifiée dans le présent document peut provoquer une exposition à des radiations dangereuses.

Normativas de seguridad

El siguiente texto incluye las medidas de seguridad que se deben seguir cuando se instale algún producto de Sun Microsystems.

Precauciones de seguridad

Para su protección observe las siguientes medidas de seguridad cuando manipule su equipo:

- Siga todas las avisos e instrucciones marcados en el equipo.
- Asegúrese de que el voltaje y la frecuencia de la red eléctrica concuerdan con las descritas en las etiquetas de especificaciones eléctricas del equipo.
- No introduzca nunca objetos de ningún tipo a través de los orificios del equipo. Pueden haber voltajes peligrosos. Los objetos extraños conductores de la electricidad pueden producir cortocircuitos que provoquen un incendio, descargas eléctricas o daños en el equipo.

Símbolos

En este libro aparecen los siguientes símbolos:



Precaución – Existe el riesgo de lesiones personales y daños al equipo. Siga las instrucciones.



Precaución – Superficie caliente. Evite el contacto. Las superficies están calientes y pueden causar daños personales si se tocan.



Precaución – Voltaje peligroso presente. Para reducir el riesgo de descarga y daños para la salud siga las instrucciones.



Encendido – Aplica la alimentación de CA al sistema.

Según el tipo de interruptor de encendido que su equipo tenga, es posible que se utilice uno de los siguientes símbolos:



Apagado – Elimina la alimentación de CA del sistema.



En espera – El interruptor de Encendido/En espera se ha colocado en la posición de *En espera*.

Modificaciones en el equipo

No realice modificaciones de tipo mecánico o eléctrico en el equipo. Sun Microsystems no se hace responsable del cumplimiento de las normativas de seguridad en los equipos Sun modificados.

Ubicación de un producto Sun



Precaución – Para asegurar la fiabilidad de funcionamiento de su producto Sun y para protegerlo de sobrecalentamientos no deben obstruirse o taparse las rejillas del equipo. Los productos Sun nunca deben situarse cerca de radiadores o de fuentes de calor.

Cumplimiento de la normativa SELV

El estado de la seguridad de las conexiones de entrada/salida cumple los requisitos de la normativa SELV.

Conexión del cable de alimentación eléctrica



Precaución – Los productos Sun están diseñados para trabajar en una red eléctrica monofásica con toma de tierra. Para reducir el riesgo de descarga eléctrica, no conecte los productos Sun a otro tipo de sistema de alimentación eléctrica. Póngase en contacto con el responsable de mantenimiento o con un electricista cualificado si no está seguro del sistema de alimentación eléctrica del que se dispone en su edificio.



Precaución – No todos los cables de alimentación eléctrica tienen la misma capacidad. Los cables de tipo doméstico no están provistos de protecciones contra sobrecargas y por tanto no son apropiados para su uso con computadores. No utilice alargadores de tipo doméstico para conectar sus productos Sun.



Precaución – Con el producto Sun se proporciona un cable de alimentación con toma de tierra. Para reducir el riesgo de descargas eléctricas conéctelo siempre a un enchufe con toma de tierra.

La siguiente advertencia se aplica solamente a equipos con un interruptor de encendido que tenga una posición "En espera":



Precaución – El interruptor de encendido de este producto funciona exclusivamente como un dispositivo de puesta en espera. El enchufe de la fuente de alimentación está diseñado para ser el elemento primario de desconexión del equipo. El equipo debe instalarse cerca del enchufe de forma que este último pueda ser fácil y rápidamente accesible. No conecte el cable de alimentación cuando se ha retirado la fuente de alimentación del chasis del sistema.

Batería de litio



Precaución – En las placas de CPU Sun hay una batería de litio insertada en el reloj de tiempo real, tipo SGS Núm. MK48T59Y, MK48TXXB-XX, MK48T18-XXXPCZ, M48T59W-XXXPCZ, o MK48T08. Las baterías no son elementos reemplazables por el propio cliente. Pueden explotar si se manipulan de forma errónea. No arroje las baterías al fuego. No las abra o intente recargarlas.

Tapa de la unidad del sistema

Debe quitar la tapa del sistema cuando sea necesario añadir tarjetas, memoria o dispositivos de almacenamiento internos. Asegúrese de cerrar la tapa superior antes de volver a encender el equipo.



Precaución – Es peligroso hacer funcionar los productos Sun sin la tapa superior colocada. El hecho de no tener en cuenta esta precaución puede ocasionar daños personales o perjudicar el funcionamiento del equipo.

Aviso de cumplimiento con requisitos de láser

Los productos Sun que utilizan la tecnología de láser cumplen con los requisitos de láser de Clase 1.

Class 1 Laser Product
Luokan 1 Laserlaite
Klasse 1 Laser Apparat
Laser Klasse 1

CD-ROM



Precaución – El manejo de los controles, los ajustes o la ejecución de procedimientos distintos a los aquí especificados pueden exponer al usuario a radiaciones peligrosas.

GOST-R Certification Mark

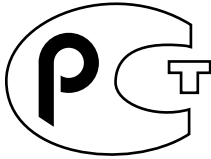

Nordic Lithium Battery Cautions

Norge



A D V A R S E L - Litiumbatteri — Eksplosjonsfare. Ved utskifting benyttes kun batteri som anbefalt av apparatfabrikanten. Brukt batteri returneres apparatleverandøren.

Sverige



WARNING - Explosionsfara vid felaktigt batteribyte. Använd samma batterityp eller en ekvivalent typ som rekommenderas av apparattillverkaren. Kassera använt batteri enligt fabrikantens instruktion.

Danmark



ADVARSEL! - Litiumbatteri — Eksplosionsfare ved fejlagtig håndtering. Udsiftning må kun ske med batteri af samme fabrikat og type. Levér det brugte batteri tilbage til leverandøren.

Suomi



VAROITUS - Paristo voi räjähtää, jos se on virheellisesti asennettu. Vaihda paristo ainoastaan laitevalmistajan suosittelemaan tyyppiin. Hävitä käytetty paristo valmistajan ohjeiden mukaisesti.

Contents

Preface xvii

UNIX Commands xvii

Installation Notes xvii

Ordering Sun Documents xxii

Sun Welcomes Your Comments xxiii

1. Drive Information 1

CD-ROM Drive 1

Software Commands 1

Cleaning a CD 1

Handling and Storing CDs 2

Inserting a CD 2

Emergency Ejection 3

Hard Disk Drive 4

Software Commands 4

Tape Drive 5

Software Commands 5

Cleaning 5

Tape Cartridge 6

- 2. Hard Drive Replacement 7**
 - ▼ Prepare the Workstation 7
 - ▼ Open the Disk Drive Enclosure 7
 - ▼ Remove the Old Drive 9
 - ▼ Install the New Drive 10
 - ▼ Replace the Cover 11
 - ▼ Connect the Cables and Turn the Power On 12

- 3. CD-ROM or Tape Drive Replacement 13**
 - ▼ Prepare the Workstation 13
 - ▼ Open the Drive Enclosure 13
 - ▼ Remove the Old Drive 14
 - ▼ Prepare the New Drive 16
 - ▼ Install the New Drive 16
 - ▼ Replace the Cover 17

Preface

This guide contains general information about Sun™ StorEdge™ UniPack CD-ROM, hard disk, and tape drives. See the specification sheet that was sent along with this documentation for drive-specific information.

UNIX Commands

This document contains brief descriptions of commonly used UNIX commands. See these sources for more specific information on commands and procedures:

- The *Solaris Handbook for SMCC Peripherals* that corresponds to your operating system
- AnswerBook™ on-line documentation, which contains the complete set of the Solaris™ 1.x or Solaris 2.x environments documentation
- Other software documentation that you received with your system

Refer to the *Solaris Handbook for SMCC Peripherals* that corresponds to your operating system for information about shutting down and configuring your system.

Installation Notes

The following notes supplement information in the *Sun StorEdge UniPack Installation* card.

Status LED

When power is applied to the enclosure, a green status LED (located on the front of the unit in the lower right corner) is lit.

If your enclosure has a hard disk, the LED blinks to show small computer system interface (SCSI) bus activity.

Note – With heavy activity, the LED on hard disk units can be off for up to ten seconds. In addition, the LED remains off during formatting, up to 15 minutes per Gbyte.

SCSI Termination

The enclosure is self-terminating. In one configuration an external terminator is required: in non ultraSCSI applications with a narrow device at the end of the SCSI bus chain. Install the external terminator on the narrow device. Contact your Sun sales representative for the terminator part number: 150-2267-xx.

Termination is indicated by two LEDs located on the back of the unit in the lower right-hand corner:

- Hi LED: Indicates that the high order SCSI bits are terminated
- Lo LED: Indicates that the low order SCSI bits are terminated

The Hi LED will be lit if the enclosure is followed by a narrow SCSI device or if the enclosure is the last device in a SCSI chain.

The Lo LED will be lit only if the enclosure is the last device in a SCSI chain.

These LEDs are for set-up and troubleshooting only and should be ignored during normal operation.

SCSI Bus Limitations

Do not connect any external tape, CD-ROM, or non-ultraSCSI UniPack unit on the same bus as an ultraSCSI device. Tapes CD-ROMs, and other non-ultraSCSI devices can be relegated to a separate host adapter containing no ultraSCSI units.

Do not connect non-ultraSCSI units to an embedded host adapter if that host adapter controls internal system ultraSCSI devices. Mixing non-ultraSCSI and ultraSCSI devices may cause the ultraSCSI devices to revert to non-ultraSCSI performance.

Patches

Operating system modifications are required for the devices discussed in this section to operate correctly. Obtain the most current revision of a patch through your service channels.

If a patch is not available, the modifications you need to make to the appropriate `conf` or `sys` files are also listed. You must be root to modify these files.



Caution – Altering a `conf` or `sys` file inappropriately can seriously affect your system's performance. If you are not familiar with this type of task, ask your system administrator for assistance.

Reboot your system after adding patches or modifying `conf` or `sys` files.

SWIS/S Wide SCSI Host Adapter

Solaris 2.x Environment

Patch

- Solaris™ 2.3 environment: Patch ID Number 101378-xx
- Solaris 2.4 environment: Patch ID Number 102509-xx

Workaround

If you cannot obtain the patch for the Solaris 2.3 or 2.4 environments, include this line in the `/etc/system` file:

```
set isp:isp_download_fw=2
```

Solaris 1.x Environment

The SWIS/S Wide SCSI Host Adapter is not supported in the Solaris 1.x environment.

1/4-Inch Tape Drive

Solaris 2.x Environment

Patch

You must install the workaround for the Solaris 2.3 or 2.4 environments; *there is no patch available.*

Workaround

Include these lines in the `/kernel/drv/st.conf` file:

```
tape-config-list=  
"TANDBERG TDC 4200", "Tandberg 2.5 Gig QIC", "TAND-25G-FIXED";  
TAND-25G-FIXED=1,0x37,512,0x867a,1,0x00,0;  
TAND-25G-VAR=1,0x37,0,0x867b,1,0x00,0;
```

For variable block size, change `FIXED` to `VAR` in the second line:

```
tape-config-list=  
"TANDBERG TDC 4200", "Tandberg 2.5 Gig QIC", "TAND-25G-VAR";  
TAND-25G-FIXED=1,0x37,512,0x867a,1,0x00,0;  
TAND-25G-VAR=1,0x37,0,0x867b,1,0x00,0;
```

Solaris 1.x Environment

Patch

You must install the workaround; *there is no patch available.*

Workaround

Include these lines in the `/usr/kvm/sys/scsi/targets/st_conf.c` file

```
/* Tandberg 2.5 Gig QIC */
{
  "Tandberg QIC 2.5 Gig QIC", 17, "TANDBERG TDC 4200",
  0x37, 512,
  (ST_QIC| ST_BSF| ST_BSR| ST_AUTODEN_OVERRIDE| ST_LONG_ERASE),
  400, 400,
  {0x00, 0x00, 0x00, 0x00},
  {0, 0, 0, 0}
},
```

Note – Rebuild the kernel after modifying the `st_conf.c` file. Follow the instructions in the `/usr/kvm/sys/`/usr/bin/arch -k`/conf/README` file.

8 mm Tape Drive

Solaris 2.x Environment

The 8 mm tape drive requires a patch only if it is being used with a SWIS/S Wide SCSI Host Adapter. See the instructions in “SWIS/S Wide SCSI Host Adapter” on page xix.

Solaris 1.x Environment

Patch

A patch is not required for Solaris 1.1.2 or later releases. For prior releases, you must install the workaround; *there is no patch available*.

Workaround

Include these lines in the `/usr/kvm/sys/scsi/targets/st_conf.c` file:

```
/* Exabyte 8505 */
{
  "Exabyte EXB-8505 8mm Helical Scan", 16, "EXABYTE EXB-8505",
  ST_TYPE_EXB8500, 1024,
  (ST_VARIABLE| ST_BSF| ST_BSR| ST_LONG_ERASE),
  5000, 5000,
  {0x14, 0x15, 0x8C, 0x8C},
  {0, 0, 0, 0}
},
```

Rebuild the kernel after modifying the `st_conf.c` file. Follow the instructions in the `/usr/kvm/sys/`/usr/bin/arch -k`/conf/README` file.

Ordering Sun Documents

SunDocsSM is a distribution program for Sun MicrosystemsTM technical documentation. Easy, convenient ordering and quick delivery is available from SunExpressTM. You can find a full listing of available documentation on the World Wide Web: <http://www.sun.com/sunexpress/>

Country	Telephone	Fax
United States	1-800-873-7869	1-800-944-0661
United Kingdom	0-800-89-88-88	0-800-89-88-87
France	05-90-61-57	05-90-61-58
Belgium	02-720-09-09	02-725-88-50
Luxembourg	32-2-720-09-09	32-2-725-88-50
Germany	01-30-81-61-91	01-30-81-61-92
The Netherlands	06-022-34-45	06-022-34-46
Sweden	020-79-57-26	020-79-57-27
Switzerland	155-19-26	155-19-27
Japan	0120-33-9096	0120-33-9097

Sun Welcomes Your Comments

You can email or fax your comments to us. Please include the part number of your document in the subject line of your email.

- Email: smcc-docs@sun.com

Drive Information

This guide contains general information about the Sun StorEdge UniPack CD-ROM, hard disk, and tape drives. See the specification sheet that was sent along with this documentation for drive-specific information.

CD-ROM Drive

Software Commands

This table contains brief descriptions of some software commands that are commonly used with CD-ROM drives. Refer to the *Solaris Handbook for SMCC Peripherals*, man pages, or AnswerBook on-line documentation for more information.

TABLE 1-1 Software Commands for CD-ROM Drives

Command	Description
mount	Attaches a file system to the file system hierarchy at the mount point, which is the path name of a directory
eject	Ejects media such as a CD-ROM or diskette from the drive

Cleaning a CD

If your drive cannot read a compact disc (CD), the CD could be dusty or dirty. Clean the CD with a soft, clean, lint-free, *dry* cloth and:

- Clean only the *non-labeled* side of the CD.

- Wipe the CD *radially* from the center to the outside of the CD.



Caution – Do not use solvents (like benzine, paint thinner, phonograph record cleaner, or antistatic aerosol spray) or abrasive cleaners to clean CDs.

Handling and Storing CDs

- Handle CDs only by their edges; avoid touching CD surfaces.
- Do not write on CDs with permanent marking pens.
- Do not use CDs in high-dust environments.
- Keep CDs out of direct sunlight, extreme sources of heat or cold, and away from dust and moisture.
- Make sure CDs are at room temperature before using them.
- Store CDs in storage boxes so that they remain clean and free of dust.

Inserting a CD

1. Push the eject button to open the drive tray.

You may need to unmount the CD before manually ejecting it.

You can also eject the CD by issuing a software command such as `eject`. See the *Solaris Handbook for SMCC Peripherals* for more information.

If your CD does not eject, see “Emergency Ejection,” which follows.

2. Place the CD, label side up, into the tray (FIGURE 1-1).

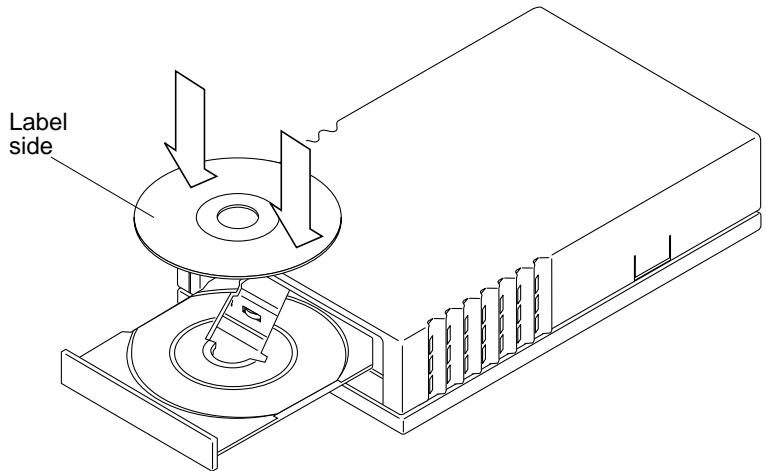

FIGURE 1-1 Inserting a CD into the CD-ROM Drive

3. Push the eject button to close the tray.

You can also close the tray by lightly pressing on the front of the tray.

Emergency Ejection



Caution – Use this procedure only if you have tried to unmount the CD and the eject button does not function. Data may be corrupted if this procedure is performed while the LED indicator is lit.

- 1. Turn off power to the CD-ROM drive.**
- 2. Use a large straightened wire paper clip (or similar object) and insert it into the emergency eject hole until the tray opens.**

The emergency eject hole is about the size of a paper clip and is located on the front of the drive near the eject button.

Hard Disk Drive

Software Commands

This table contains brief descriptions of some software commands that are commonly used with hard disk drives. Refer to the *Solaris Handbook for SMCC Peripherals*, man pages, or AnswerBook on-line documentation for more information.

TABLE 1-2 Software Commands Used with Hard Disks

Command	Description
mount	Attaches a file system to the file system hierarchy at the mount point, which is the path name of a directory
newfs	Makes <code>ufs</code> file systems on disk partitions
format	Formats, labels, repairs, and analyzes disks on your system

Refer to the AnswerBook on-line documentation that came with your operating system for more information.

Tape Drive

Software Commands

This table contains brief descriptions of some software commands that are commonly used with tape drives. Refer to the *Solaris Handbook for SMCC Peripherals*, man pages or AnswerBook on-line documentation for more information.

TABLE 1-3 Software Commands for Tape Drives

Command	Description
cpio	Copies file archives in and out
mt	Sends commands to a magnetic tape drive
tapetool	Reads files from tape or archives files to tape
st	Acts as a device driver and interface to SCSI tape devices
tar	Creates tape archives and adds or extracts files
ufsdump	Backs up partitions and/or the entire disk
ufsrestore	Moves data from tape back to the disk

Cleaning

You must clean the tape drive regularly to maintain reliable operation. The frequency of cleaning depends on which tape drive you have. Refer to the cleaning information in your tape drive specifications sheet.

Use only cleaning cartridges that are approved for your tape drive. Approved cleaning cartridges are listed in your tape drive specifications sheet.

Follow the cleaning instructions included with the cleaning cartridge. These cartridges are available from many computer supply companies.



Caution – Do not use cleaning cartridges or fluids designed for use in video or audio devices. These cartridges or fluids can damage the tape drive.

Tape Cartridge

Use only tape cartridges that are approved for your tape drive. Approved tape cartridges are listed in your tape drive specifications sheet.

These tape cartridges require no pre-formatting and are available from many computer supply companies.

Note – Do not use video or audio tapes; use only data-grade tape cartridges.

Thermal Conditioning

To ensure proper thermal conditioning, keep the cartridge at the same temperature as the drive for 24 hours.

Write-Protection

When the tape is write-protected (read-only mode), data on the tape cannot be overwritten. When the tape is write-enabled, you can write and store new data on the tape.

For information on how to write protect a tape cartridge, refer to your tape drive specifications sheet or documentation that is contained with the tape cartridge.

Tensioning Pass

When you insert a *blank* 1/4-inch tape cartridge or one that has been stored for a long time, run it from one end to the other. This tensioning pass ensures an even distribution of tension throughout the tape. See the *Solaris Handbook for SMCC Peripherals* for specific instructions about tensioning a tape cartridge.

Handling and Storage

- Avoid touching the surface of the tape.
- Make sure the cartridge is at room temperature before using it.
- Keep cartridges away from anything magnetic.
- Keep cartridges out of direct sunlight and sources of heat, cold, or humidity.
- Rewind a cartridge before storing.
- Store cartridges in a dust-free environment, upright on edge rather than flat.
- Maintain stable temperature for long term cartridge storage.
- Maintain stable humidity (near 50%) for long term cartridge storage.

Hard Drive Replacement

To replace a hard disk drive in a Sun Sun StorEdge UniPack enclosure, you must shut down the operating system, turn off the power, and open the enclosure before replacing the drive.

▼ Prepare the Workstation

1. Halt the operating system.

See the *Solaris™ Handbook for SMCC Peripherals* that came with your system, or on the *Solaris AnswerBook®* on-line documentation for the appropriate command.

2. Turn off the power to the workstation and peripherals.

Be sure the AC power cord to the wall socket remains connected for electrical grounding.

▼ Open the Disk Drive Enclosure

1. If you have a security cable, remove it and the screw at the center rear of the drive.

- a. Open the enclosure by pressing inward on the side tabs and lifting the rear of the cover.**

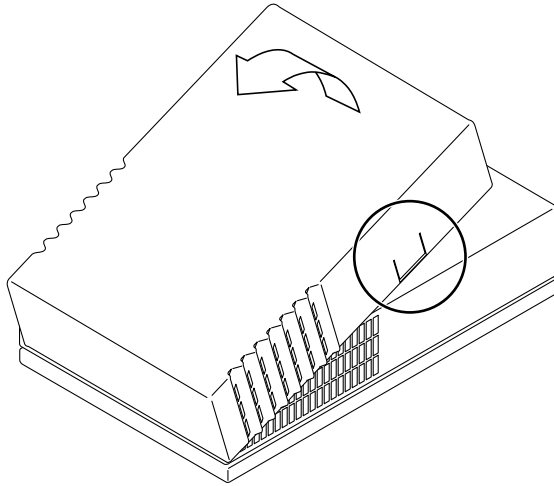

FIGURE 2-1 Opening the Enclosure

2. **Carefully remove the acoustic foam if any, that covers the disk drive.**
The foam has finger holes for easy removal.



Caution – Do not remove the power supply unless you are a trained service provider.

3. **Wrap a wrist strap several times around your wrist and attach the copper end to the unpainted surface of the power supply.**

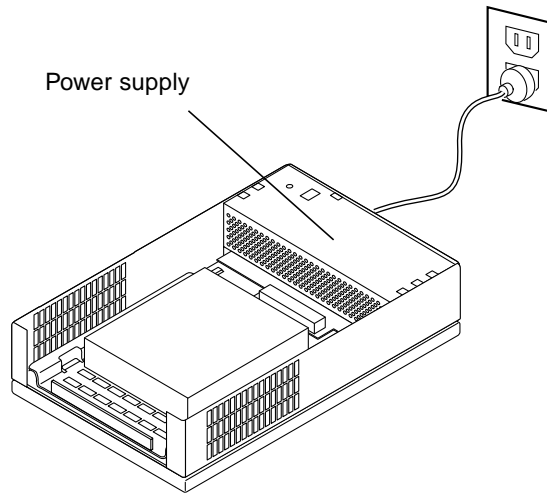

FIGURE 2-2 Sun StorEdge UniPack Without the Cover

▼ Remove the Old Drive

1. **Look at the bottom of the drive enclosure.**
2. **Pull out the tab on the bottom of the base as you pull the bracket forward gently.**
The front of the bracket has a finger pull.
3. **Remove the drive and bracket from the enclosure.**

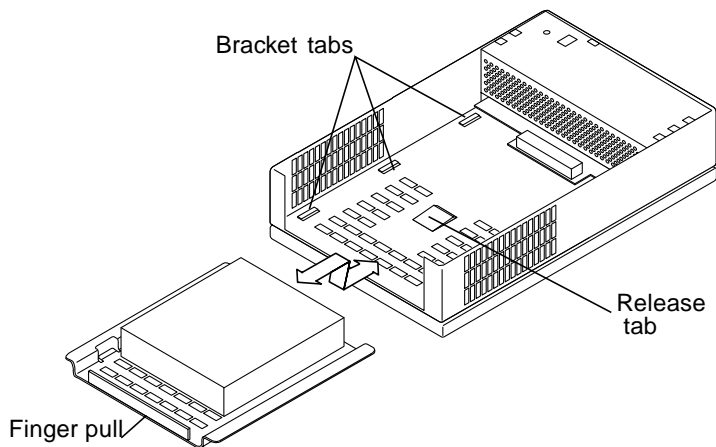

FIGURE 2-3 Removing or Replacing the Bracket and Drive

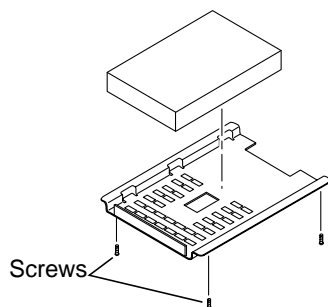

FIGURE 2-4 Removing or Attaching Bracket and Drive

4. Remove the old hard drive from the bracket.

Four screws at the bottom secure the drive.

▼ Install the New Drive

1. **Unpack the new drive and place it upside down on the antistatic bag it came in.**
2. **Secure the new drive to the drive bracket with the four screws.**
3. **Place the drive and bracket into the enclosure just inside the front.**

4. Slide the drive and bracket under the six bracket tabs.

Release the tab on the underside of the case to ease the insertion. The drive connector locks into the connector on the power supply.

▼ Replace the Cover

- 1. Remove the wrist strap and check that the enclosure is clear of anything but the drive and power supply.**
- 2. Replace the acoustic foam, if any, over the disk drive.**

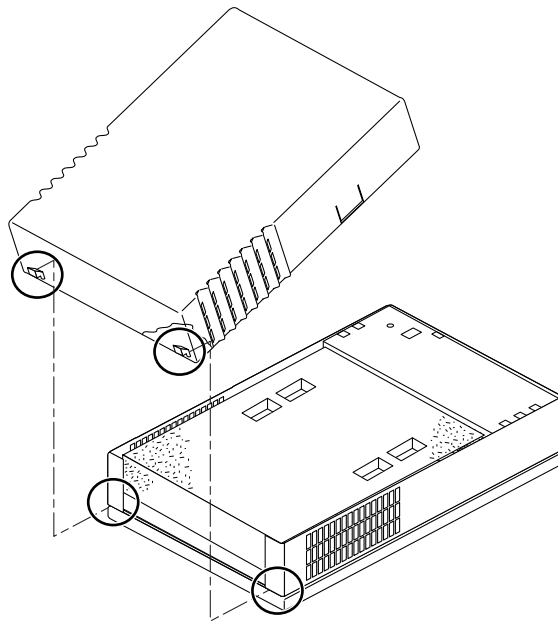

FIGURE 2-5 Replacing the Cover

3. Replace the cover.

- a. At the front, fit the small hooks at each side of the cover through the holes in the metal casing.**
- b. Lower the cover until it clicks into place**

▼ Connect the Cables and Turn the Power On

1. Connect the cables.

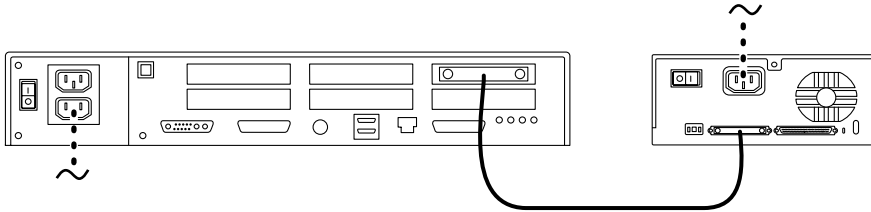

FIGURE 2-6 Attaching the SCSI Cable

2. Turn on the power to the peripherals and the workstation.

CD-ROM or Tape Drive Replacement

To replace a CD-ROM or tape drive in a Sun Sun StorEdge UniPack enclosure, you must shut down the operating system, turn off the power, and open the enclosure before replacing the drive.

▼ Prepare the Workstation

1. Halt the workstation operating system.

See the *Solaris™ Handbook for SMCC Peripherals* that comes with your system. You can also find the handbook on the *Solaris AnswerBook®* on-line documentation.

2. Turn off the power to the workstation and peripherals.

Be sure the AC power cord between the drive and the wall socket remains connected for electrical grounding.

3. Disconnect the cable between the drive and the workstation.

▼ Open the Drive Enclosure

1. If you have a security cable, remove it and the screw at the center rear of the drive.

2. Open the drive enclosure by pressing inward on the side tabs and lifting the rear of the cover.

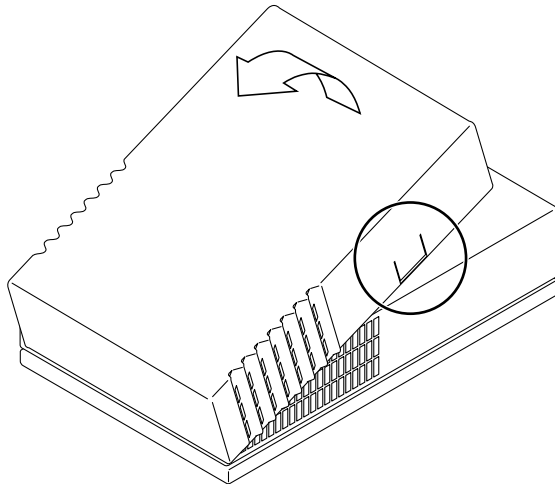

FIGURE 3-1 Removing the Enclosure Cover



Caution – Do not remove the power supply unless you are a trained service provider.

3. **Wrap a wrist strap several times around your wrist and attach the copper end to the unpainted surface of the power supply.**

▼ Remove the Old Drive

1. **Look at the bottom of the drive enclosure.**
2. **Pull out the tab while pulling the drive and bracket forward.**
The internal cables remain connected to the drive.

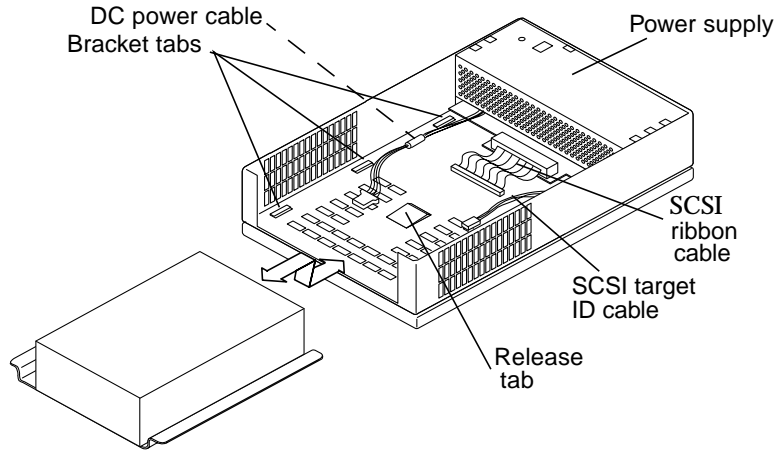

FIGURE 3-2 Sun Sun StorEdge UniPack Enclosure Without the Cover

1. Note the position of the SCSI target ID cable on the pin connector on the back of the drive so you can replace it correctly on the new drive..

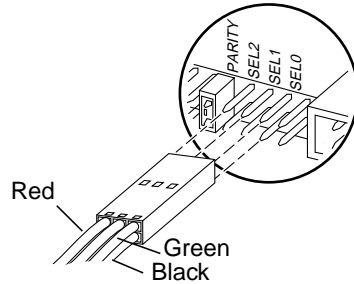

FIGURE 3-3 A Typical SCSI ID Cable Connection

2. Disconnect the DC power, SCSI ribbon, and SCSI target ID cables from the drive and remove the drive and bracket from the chassis.
3. Remove the old drive from the bracket.
Four screws attach the drive to the bracket.

▼ Prepare the New Drive

1. **Unpack the new drive and place it on the antistatic bag it came in.**
Ensure that the jumpers are set correctly by checking the settings on the old drive.
2. **Align the drive so it will fit when the cover is replaced.**
 - a. **Place the new drive upside down inside the enclosure cover, lining up the drive's front panel with the first rib of the cover.**
 - b. **Start each screw.**
 - c. **Place the bracket upside down on top of the drive, lining up the score mark on the bracket with the second interior rib on the cover.**
 - d. **Tighten the screws.**

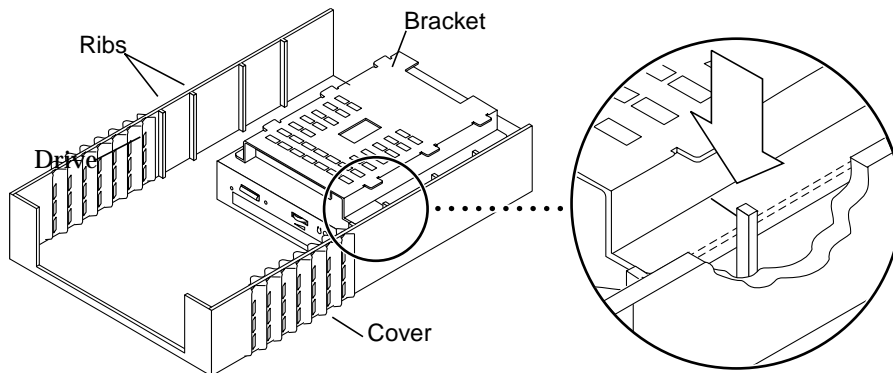

FIGURE 3-4 Aligning the Drive

▼ Install the New Drive

1. **Place the drive and bracket into the enclosure just inside the front.**
2. **Connect the SCSI target ID cable to the drive.**
The green wire is connected to Sel0. See the map on the back of the drive.
3. **Connect the DC power cable and the SCSI ribbon cable.**
4. **Slide the drive and bracket under the six bracket tabs.**
Release the tab on the bottom of the base to ease the insertion of the bracket and drive.

▼ Replace the Cover

1. Replace the cover.
2. At the front, fit the small hooks at each side of the cover through the holes in the metal casing.
Lower the cover until it clicks into place.

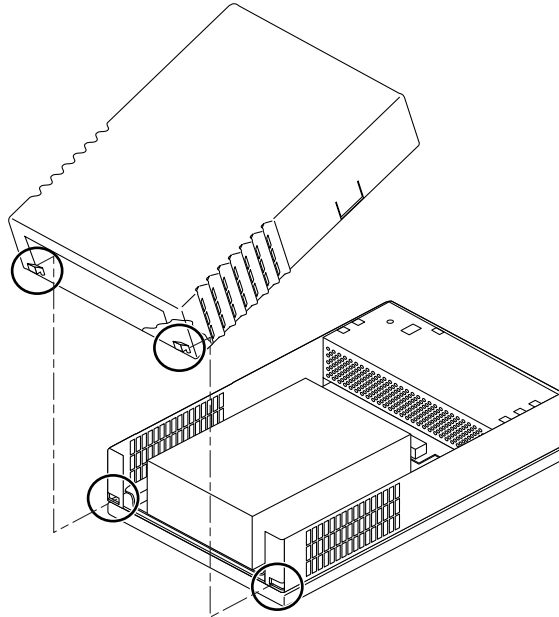

FIGURE 3-5 Replacing the Cover

FIGURE 3-6 Connecting the SCSI Cable

3. Connect the cables and turn on the power to the peripherals and the workstation (FIGURE 3-6).

Internal and External Cable Lengths

External SCSI Cable Length

To connect a StorEdge UniPack enclosure to the onboard host port of an UltraSCSI capable host, use only a .8 meter cable.

To connect a StorEdge UniPack enclosure to an UltraSCSI host adapter, you can use a .8 meter cable.

To directly connect a StorEdge UniPack enclosure to your desktop system, or to daisy chain it to another SCSI peripheral, use the UltraSCSI cable that ships with the unit.



Caution – Using cables other than those recommended by Sun may result in data loss.

TABLE A-1 SCSI External Cable Lengths

Cables	Meters	Inches
68-68 pin cable	0.8	31.4
50-68 pin cable	1.2	47.2
68-68 pin cable or 50-68 pin cable	2.0	78.6

Internal SCSI Cable Length

The StorEdge UniPack enclosure does not use internal cables. TABLE A-2 lists the internal cable lengths of supported systems.

TABLE A-2 Internal Cable Lengths of Supported Systems

Devices and Cables	SCSI Cable Length	
	Meters	Inches
Sun StorEdge UniPack (rem. media)	0.4	15.7
Sun StorEdge UniPack (disk)	0.3	11.8
Sun StorEdge MultiPack	0.9	35.4
Desktop Disk Pack (tape, disk, CD-ROM)	0.3	11.8
Ultra™ 1 Model 140, Model 170	0.9	35.4
Ultra™ 1 Creator and Ultra™ 1 Creator 3D	0.9	35.4
Ultra Enterprise 450	0.9	35.4
Ultra™ 2 Creator and Ultra™ 2 Creator 3D	0.9	35.4
Ultra 30	0.9	35.4
SPARCstation™ 5, 20	1.6	62.6
SPARCstation 4	1.2	48.0
SPARCstation 10, LX, SPARCclassic	0.9	35.4
SPARCstation™ Voyager™	0.4	15.7
SPARCserver™ 1000	1.8	70.2
SBus cards (SBE/S, FSBE/S, SBus SCSI host adapter)	0.1	3.9
Sun Swift PCI Adapter	0.1	3.9
PCI Ultra Single-Ended 2 Channel SCSI Adapter	0.2	7.8
SBus Expansion Subsystem	0.9	35.4