

Sun Ultra™ 30 Service Manual



THE NETWORK IS THE COMPUTER™

Sun Microsystems, Inc.
901 San Antonio Road
Palo Alto, CA 94303-4900 USA
650 960-1300 Fax 650 969-9131

Part No.: 802-7719-12
April 1998, Revision A

Send comments about this document to: docfeedback@sun.com

Copyright 1999 Sun Microsystems, Inc., 901 San Antonio Road, Palo Alto, California 94303-4900 U.S.A. All rights reserved.

This product or document is protected by copyright and distributed under licenses restricting its use, copying, distribution, and decompilation. No part of this product or document may be reproduced in any form by any means without prior written authorization of Sun and its licensors, if any. Third-party software, including font technology, is copyrighted and licensed from Sun suppliers.

Parts of the product may be derived from Berkeley BSD systems, licensed from the University of California. UNIX is a registered trademark in the U.S. and other countries, exclusively licensed through X/Open Company, Ltd. For Netscape Communicator™, the following notice applies: (c) Copyright 1995 Netscape Communications Corporation. All rights reserved.

Sun, Sun Microsystems, the Sun logo, SunStore, AnswerBook2, docs.sun.com, and Solaris are trademarks, registered trademarks, or service marks of Sun Microsystems, Inc. in the U.S. and other countries. All SPARC trademarks are used under license and are trademarks or registered trademarks of SPARC International, Inc. in the U.S. and other countries. Products bearing SPARC trademarks are based upon an architecture developed by Sun Microsystems, Inc.

The OPEN LOOK and Sun™ Graphical User Interface was developed by Sun Microsystems, Inc. for its users and licensees. Sun acknowledges the pioneering efforts of Xerox in researching and developing the concept of visual or graphical user interfaces for the computer industry. Sun holds a non-exclusive license from Xerox to the Xerox Graphical User Interface, which license also covers Sun's licensees who implement OPEN LOOK GUIs and otherwise comply with Sun's written license agreements.

RESTRICTED RIGHTS: Use, duplication, or disclosure by the U.S. Government is subject to restrictions of FAR 52.227-14(g)(2)(6/87) and FAR 52.227-19(6/87), or DFAR 252.227-7015(b)(6/95) and DFAR 227.7202-3(a).

DOCUMENTATION IS PROVIDED "AS IS" AND ALL EXPRESS OR IMPLIED CONDITIONS, REPRESENTATIONS AND WARRANTIES, INCLUDING ANY IMPLIED WARRANTY OF MERCHANTABILITY, FITNESS FOR A PARTICULAR PURPOSE OR NON-INFRINGEMENT, ARE DISCLAIMED, EXCEPT TO THE EXTENT THAT SUCH DISCLAIMERS ARE HELD TO BE LEGALLY INVALID.

Copyright 1999 Sun Microsystems, Inc., 901 San Antonio Road, Palo Alto, Californie 94303-4900 U.S.A. Tous droits réservés.

Ce produit ou document est protégé par un copyright et distribué avec des licences qui en restreignent l'utilisation, la copie, la distribution, et la décompilation. Aucune partie de ce produit ou document ne peut être reproduite sous aucune forme, par quelque moyen que ce soit, sans l'autorisation préalable et écrite de Sun et de ses bailleurs de licence, s'il y en a. Le logiciel détenu par des tiers, et qui comprend la technologie relative aux polices de caractères, est protégé par un copyright et licencié par des fournisseurs de Sun.

Des parties de ce produit pourront être dérivées des systèmes Berkeley BSD licenciés par l'Université de Californie. UNIX est une marque déposée aux Etats-Unis et dans d'autres pays et licenciée exclusivement par X/Open Company, Ltd. La notice suivante est applicable à Netscape Communicator™ : (c) Copyright 1995 Netscape Communications Corporation. All rights reserved.

Sun, Sun Microsystems, le logo Sun, SunStore, AnswerBook2, docs.sun.com, et Solaris sont des marques de fabrique ou des marques déposées, ou marques de service, de Sun Microsystems, Inc. aux Etats-Unis et dans d'autres pays. Toutes les marques SPARC sont utilisées sous licence et sont des marques de fabrique ou des marques déposées de SPARC International, Inc. aux Etats-Unis et dans d'autres pays. Les produits portant les marques SPARC sont basés sur une architecture développée par Sun Microsystems, Inc.

L'interface d'utilisation graphique OPEN LOOK et Sun™ a été développée par Sun Microsystems, Inc. pour ses utilisateurs et licenciés. Sun reconnaît les efforts de pionniers de Xerox pour la recherche et le développement du concept des interfaces d'utilisation visuelle ou graphique pour l'industrie de l'informatique. Sun détient une licence non exclusive de Xerox sur l'interface d'utilisation graphique Xerox, cette licence couvrant également les licenciés de Sun qui mettent en place l'interface d'utilisation graphique OPEN LOOK et qui en outre se conforment aux licences écrites de Sun.

CETTE PUBLICATION EST FOURNIE "EN L'ETAT" ET AUCUNE GARANTIE, EXPRESSE OU IMPLICITE, N'EST ACCORDEE, Y COMPRIS DES GARANTIES CONCERNANT LA VALEUR MARCHANDE, L'APTITUDE DE LA PUBLICATION A REPOUDRE A UNE UTILISATION PARTICULIERE, OU LE FAIT QU'ELLE NE SOIT PAS CONTREFAISANTE DE PRODUIT DE TIERS. CE DENI DE GARANTIE NE S'APPLIQUERAIT PAS, DANS LA MESURE OU IL SERAIT TENU JURIDIQUEMENT NUL ET NON AVENU.



Adobe PostScript

Contents

Preface xix

How This Book Is Organized xix

UNIX Commands xx

Typographic Conventions xxi

Shell Prompts xxi

Related Documents xxii

Sun Documentation on the Web xxiii

Sun Welcomes Your Comments xxiii

1. Product Description 1-1

1.1 I/O Devices 1-2

1.2 System Unit Features 1-3

1.3 System Unit Components 1-5

2. SunVTS Overview 2-1

2.1 SunVTS Description 2-1

2.2 SunVTS Operation 2-2

3. Power-On Self-Test 3-1

3.1 POST Overview 3-1

3.2 Pre-POST Preparation 3-2

- 3.2.1 Setting Up a Tip Connection 3-2
- 3.2.2 Verifying the Baud Rate 3-4
- 3.3 Initializing POST 3-4
- 3.4 Maximum and Minimum Levels of POST 3-5
 - 3.4.1 diag-level Variable Set to max 3-6
 - 3.4.2 diag-level Variable Set to min 3-12
- 3.5 POST Progress and Error Reporting 3-18
- 3.6 Bypassing POST 3-20
- 3.7 Additional Keyboard Control Commands 3-20
- 3.8 System and Keyboard LEDs 3-20
- 3.9 Motherboard Test 3-21
- 4. Troubleshooting Procedures 4-1**
 - 4.1 Power-On Failure 4-1
 - 4.2 Video Output Failure 4-2
 - 4.3 Hard Drive or CD-ROM Drive Failure 4-3
 - 4.4 Power Supply Test 4-4
 - 4.5 DIMM Failure 4-6
 - 4.6 OpenBoot PROM On-Board Diagnostics 4-7
 - 4.6.1 watch-clock 4-7
 - 4.6.2 watch-net and watch-net-all 4-8
 - 4.6.3 probe-scsi and probe-scsi-all 4-9
 - 4.6.4 test *alias name, device path, -all* 4-10
 - 4.6.5 UPA Graphics Card 4-11
 - ▼ To initialize the UPA graphics card diagnostic: 4-11
 - 4.7 OpenBoot Diagnostics 4-12
 - ▼ To initialize the OBdiag menu: 4-12
 - 4.7.1 PCI/PCIO 4-16
 - 4.7.2 EBus DMA/TCR Registers 4-17
 - 4.7.3 Ethernet 4-17

- 4.7.4 Keyboard 4-18
- 4.7.5 Mouse 4-19
- 4.7.6 Floppy 4-19
- 4.7.7 Parallel Port 4-20
- 4.7.8 Serial Port A 4-20
- 4.7.9 Serial Port B 4-21
- 4.7.10 NVRAM 4-22
- 4.7.11 Audio 4-23
- 4.7.12 SCSI 4-23
- 4.7.13 All Above 4-24

▼ To recover the original N1fsVRAM variable settings: 4-26

5. Safety and Tool Requirements 5-1

- 5.1 Safety Requirements 5-1
- 5.2 Symbols 5-1
- 5.3 Safety Precautions 5-2
 - 5.3.1 Modification to Equipment 5-2
 - 5.3.2 Placement of a Sun Product 5-2
 - 5.3.3 Power Cord Connection 5-3
 - 5.3.4 Electrostatic Discharge 5-3
 - 5.3.5 Lithium Battery 5-3
- 5.4 Tools Required 5-3

6. Power On and Off 6-1

- 6.1 Powering On the System Unit 6-1
- 6.2 Powering Off the System Unit 6-3

7. Internal Access 7-1

- 7.1 Removing the Side Access Cover 7-1
- 7.2 Attaching the Wrist Strap 7-4
- 7.3 Replacing the Side Access Cover 7-5

8. Major Subassemblies 8-1

- 8.1 Power Supply 8-1**
 - 8.1.1 Removing the Power Supply 8-2
 - 8.1.2 Replacing the Power Supply 8-4
- 8.2 PCI Fan Assembly 8-5**
 - 8.2.1 Removing the PCI Fan Assembly 8-5
 - 8.2.2 Replacing the PCI Fan Assembly 8-7
- 8.3 Hard Drive Bay With SCSI Assembly 8-7**
 - 8.3.1 Removing the SCSI Drive Bay 8-7
 - 8.3.2 Replacing the SCSI Drive Bay 8-9
- 8.4 Cable Assemblies 8-10**
 - 8.4.1 Removing the Peripheral Power Cable Assembly 8-10
 - 8.4.2 Replacing the Peripheral Power Cable Assembly 8-11
 - 8.4.3 Removing the Diskette Drive Cable Assembly 8-12
 - 8.4.4 Replacing the Diskette Drive Cable Assembly 8-13
 - 8.4.5 Removing the UPA Graphics Card Cable Assembly 8-13
 - 8.4.6 Replacing the UPA Graphics Card Cable Assembly 8-16
- 8.5 EMI Filler Panels 8-16**
 - 8.5.1 Removing an EMI Filler Panel 8-17
 - 8.5.2 Replacing an EMI Filler Panel 8-18
- 8.6 Chassis Foot 8-18**
 - 8.6.1 Removing the Chassis Foot 8-18
 - 8.6.2 Replacing the Chassis Foot 8-19
- 8.7 Speaker Assembly 8-20**
 - 8.7.1 Removing the Speaker Assembly 8-20
 - 8.7.2 Replacing the Speaker Assembly 8-21
- 8.8 DC Switch Assembly 8-22**
 - 8.8.1 Removing the DC Switch Assembly 8-22
 - 8.8.2 Replacing the DC Switch Assembly 8-24

8.9	Shroud Assembly	8-25
8.9.1	One-Piece Shroud Assembly	8-25
8.9.1.1	Removing the One-Piece Shroud Assembly	8-26
8.9.1.2	Replacing the One-Piece Shroud Assembly	8-27
8.9.2	Two-Piece Shroud Assembly	8-28
8.9.2.1	Removing the Two-Piece Shroud Assembly	8-28
8.9.2.2	Replacing the Two-Piece Shroud Assembly	8-30
8.9.3	Two-Piece Shroud Fan Assembly	8-30
8.9.3.1	Removing the Two-Piece Shroud Fan Assembly	8-31
8.9.3.2	Replacing the Two-Piece Shroud Fan Assembly	8-32
9.	Storage Devices	9-1
9.1	Hard Drive	9-1
9.1.1	Removing a Hard Drive	9-1
9.1.2	Replacing a Hard Drive	9-3
9.2	Removable Media Assembly Drive	9-4
9.2.1	Removing the RMA	9-4
9.2.2	Removing a CD-ROM Drive or 4-mm/8-mm Tape Drive	9-6
9.2.3	Replacing a CD-ROM Drive or 4-mm/8-mm Tape Drive	9-7
9.2.4	Removing a Diskette Drive	9-7
9.2.5	Replacing a Diskette Drive	9-7
9.2.6	Replacing the RMA	9-8
10.	Motherboard and Component Replacement	10-1
10.1	CPU Module	10-1
10.1.1	Removing the CPU Module	10-2
10.1.2	Replacing the CPU Module	10-3
10.2	NVRAM/TOD	10-4
10.2.1	Removing the NVRAM/TOD	10-4
10.2.2	Replacing the NVRAM/TOD	10-5

- 10.3 PCI Card 10-6
 - 10.3.1 Removing a PCI Card 10-6
 - 10.3.2 Replacing a PCI Card 10-8
- 10.4 UPA Graphics Card 10-9
 - 10.4.1 Removing a UPA Graphics Card 10-9
 - 10.4.2 Replacing a UPA Graphics Card 10-11
- 10.5 DIMM 10-12
 - 10.5.1 Removing a DIMM 10-13
 - 10.5.2 Replacing a DIMM 10-14
- 10.6 Audio Card 10-16
 - 10.6.1 Removing the Audio Card 10-16
 - 10.6.2 Replacing the Audio Card 10-17
- 10.7 Motherboard 10-18
 - 10.7.1 Removing the Motherboard 10-19
 - 10.7.2 Replacing the Motherboard 10-22

11. Illustrated Parts List 11-1

A. Product Specifications A-1

- A.1 Physical Specifications A-1
- A.2 Electrical Specifications A-2
- A.3 Environmental Requirements A-2

B. Signal Descriptions B-1

- B.1 Keyboard/Mouse and Serial Ports A and B B-1
 - B.1.1 Keyboard/Mouse Connector B-1
 - B.1.2 Serial Port A and B Connectors B-2
- B.2 Twisted-Pair Ethernet Connector B-5
- B.3 UltraSCSI Connector B-6
- B.4 Audio Connectors B-10
- B.5 Parallel Port Connector B-11

B.6 Media Independent Interface Connector B-13

B.7 UPA Graphics Card Connector B-15

C. Functional Description C-1

C.1 System Unit C-1

C.1.1 UPA C-4

C.1.2 PCI Bus C-5

C.1.2.1 U2P ASIC C-5

C.1.2.2 Symbios 53C875 SCSI Controller C-6

C.1.2.3 PCIO ASIC C-6

C.1.3 UltraSPARC II Processor C-6

C.1.4 Memory System C-7

C.1.4.1 DIMM C-11

C.1.4.2 Memory System Timing C-13

C.1.4.3 Graphics Card Features C-13

C.1.4.4 Graphics Card Performance C-14

C.1.5 Peripherals C-14

C.1.5.1 CD-ROM Drive C-15

C.1.5.2 Diskette Drive C-15

C.1.5.3 Hard Drives C-17

C.1.5.4 Optional 4-mm or 8-mm Tape Drive C-18

C.1.6 Keyboard and Mouse, Diskette, and Parallel Port C-19

C.1.6.1 Keyboard and Mouse Port C-19

C.1.6.2 Diskette Port C-20

C.1.6.3 Parallel Port C-20

C.1.7 Serial Port C-21

C.1.7.1 Serial Port Components C-21

C.1.7.2 Serial Port Functions C-22

C.1.7.3 EIA Levels C-23

C.1.7.4 Synchronous Rates C-23

C.1.7.5 Asynchronous Rates C-23

C.1.7.6 Slew Rate and Cable Length C-23

C.1.8	Ethernet	C-24
C.1.8.1	Automatic Negotiation	C-25
C.1.8.2	External Transceivers	C-25
C.1.8.3	External Cables	C-25
C.1.8.4	Connectors	C-25
C.1.8.5	MII Power	C-26
C.1.8.6	MII Port Timing	C-26
C.1.9	Audio Card and Connector	C-27
C.1.10	SCSI	C-28
C.1.10.1	Host Adapter	C-29
C.1.10.2	Supported Target Devices	C-30
C.1.10.3	External Cables	C-30
C.1.10.4	Internal SCSI Subassembly	C-30
C.1.10.5	SCSI ID Selection	C-31
C.1.11	ASIC	C-32
C.1.11.1	SC_UP+	C-32
C.1.11.2	UltraBMX	C-33
C.1.11.3	PCIO	C-33
C.1.11.4	U2P	C-33
C.1.11.5	FBC	C-34
C.1.11.6	RISC	C-34
C.1.12	SuperIO	C-34
C.1.13	Power Supply	C-35
C.1.14	Control Signals	C-36
C.1.14.1	Remote Enable PowerOn and PowerOff	C-36
C.1.14.2	ON/OFF Functionality	C-36
C.1.14.3	System Unit Power Budget	C-37
C.1.15	Built-In Speaker	C-40
C.1.16	Microphone	C-41
C.1.17	Standard System Facilities	C-41
C.2	Motherboard	C-41

- C.3 Jumper Descriptions C-43
 - C.3.1 Serial Port Jumpers C-44
 - C.3.2 Flash PROM Jumpers C-45
- C.4 Enclosure C-45
 - C.4.1 Enclosure Basics C-45
 - C.4.2 Enclosure Features C-46
- C.5 Environmental Compliance C-46
- C.6 Agency Compliance C-46

Glossary Glossary-1

Figures

- FIGURE 1-1 Sun Ultra 30 Desktop Workstation 1-2
- FIGURE 1-2 System Unit Front View 1-3
- FIGURE 1-3 System Unit Rear View 1-4
- FIGURE 3-1 Setting Up a `tip` Connection 3-3
- FIGURE 3-2 Sun Type-5 Keyboard 3-5
- FIGURE 4-1 Power Supply Connector J2901 4-5
- FIGURE 4-2 Power Supply Connector J2902 4-5
- FIGURE 4-3 Power Supply Connector J2903 4-6
- FIGURE 6-1 System Power On (Front Panel) 6-2
- FIGURE 6-2 Sun Type-5 Keyboard 6-2
- FIGURE 6-3 System Power Off (Front Panel) 6-4
- FIGURE 7-1 Lock Block Location 7-2
- FIGURE 7-2 Removing the Side Access Cover 7-3
- FIGURE 7-3 Attaching the Wrist Strap 7-5
- FIGURE 7-4 Replacing the Side Access Cover 7-6
- FIGURE 8-1 Removing and Replacing the Power Supply (Part 1 of 2) 8-3
- FIGURE 8-2 Removing and Replacing the Power Supply (Part 2 of 2) 8-4
- FIGURE 8-3 Removing and Replacing the PCI Fan Assembly 8-6
- FIGURE 8-4 Removing and Replacing the SCSI Drive Bay 8-9
- FIGURE 8-5 Removing and Replacing the UPA Graphics Card Cable Assembly 8-15

FIGURE 8-6	Removing and Replacing the Bezel EMI Filler Panel	8-17
FIGURE 8-7	Removing and Replacing the RMA EMI Filler Panel	8-18
FIGURE 8-8	Removing and Replacing the Chassis Foot	8-19
FIGURE 8-9	Removing and Replacing the Speaker Assembly	8-21
FIGURE 8-10	Removing and Replacing the DC Switch Assembly	8-24
FIGURE 8-11	Removing and Replacing the One-Piece Shroud Assembly (Part 1 of 2)	8-26
FIGURE 8-12	Removing and Replacing the One-Piece Shroud Assembly (Part 2 of 2)	8-27
FIGURE 8-13	Removing and Replacing the Two-Piece Shroud Assembly	8-29
FIGURE 8-14	Removing and Replacing the Two-Piece Shroud Fan Assembly	8-32
FIGURE 9-1	Removing and Replacing a Hard Drive	9-3
FIGURE 9-2	Removing and Replacing the RMA Drive (Part 1 of 2)	9-5
FIGURE 9-3	Removing and Replacing the RMA Drive (Part 2 of 2)	9-6
FIGURE 10-1	Removing and Replacing the CPU Module	10-3
FIGURE 10-2	Removing and Replacing the NVRAM/TOD	10-5
FIGURE 10-3	Removing and Replacing a PCI Card	10-7
FIGURE 10-4	Removing and Replacing a UPA Graphics Card	10-10
FIGURE 10-5	DIMM Ejection Lever	10-13
FIGURE 10-6	Removing and Replacing a DIMM	10-14
FIGURE 10-7	Removing and Replacing the Audio Card	10-18
FIGURE 10-8	Removing and Replacing the Motherboard (Part 1 of 2)	10-21
FIGURE 10-9	Removing and Replacing the Motherboard (Part 2 of 2)	10-22
FIGURE 10-10	Location of the Motherboard Serial Port Jumpers	10-23
FIGURE 10-11	Identifying Jumper Pins	10-24
FIGURE 11-1	System Unit Exploded View	11-3
FIGURE B-1	Keyboard/Mouse Connector Pin Configuration	B-2
FIGURE B-2	Serial Port A and B Connector Pin Configurations	B-3
FIGURE B-3	TPE Connector Pin Configuration	B-6
FIGURE B-4	UltraSCSI Connector Pin Configuration	B-7
FIGURE B-5	Audio Connector Configuration	B-10
FIGURE B-6	Parallel Port Connector Pin Configuration	B-11

FIGURE B-7	MII Connector Pin Configuration	B-13
FIGURE B-8	UPA Graphics Card Con	B-16
FIGURE C-1	System Unit Functional Block Diagram	C-3
FIGURE C-2	UPA Address and Data Buses Functional Block Diagram	C-5
FIGURE C-3	Memory System Functional Block Diagram	C-8
FIGURE C-4	Memory Module Functional Block Diagram (Part 1 of 2)	C-9
FIGURE C-5	Memory Module Functional Block Diagram (Part 2 of 2)	C-10
FIGURE C-6	DIMM Row Mapping	C-11
FIGURE C-7	Keyboard and Mouse, Diskette, and Parallel Port Functional Block Diagram	C-19
FIGURE C-8	Serial Port Functional Block Diagram	C-22
FIGURE C-9	MII Port Timing Model	C-26
FIGURE C-10	Audio Card Functional Block Diagram	C-28
FIGURE C-11	Configuration for the SCSI Bus	C-29
FIGURE C-12	SCSI Subassembly Functional Block Diagram	C-31
FIGURE C-13	System Unit Motherboard Functional Block Diagram	C-42
FIGURE C-14	Selected Jumper Settings	C-43
FIGURE C-15	Identifying Jumper Pins	C-43

Tables

TABLE P-1	Document Organization	xix
TABLE P-2	Typographic Conventions	xxi
TABLE P-3	Shell Prompts	xxi
TABLE P-4	Related Documents	xxii
TABLE 1-1	Supported I/O Devices	1-2
TABLE 1-2	Ultra 30 System Unit Replaceable Components	1-5
TABLE 2-1	SunVTS Documentation	2-2
TABLE 3-1	<code>diag-switch?</code> and <code>diag-level</code> Flag Settings	3-2
TABLE 3-2	Keyboard LED Patterns	3-19
TABLE 4-1	Internal Drives Identification	4-3
TABLE 4-2	Power Supply Connector J2901 Pin Assignments	4-5
TABLE 4-3	Power Supply Connector J2902 Pin Assignments	4-5
TABLE 4-4	Power Supply Connector J2903 Pin Assignments	4-6
TABLE 4-5	DIMM Physical Memory Addresses	4-6
TABLE 4-6	Selected OBP On-Board Diagnostic Tests	4-10
TABLE 10-1	DIMM Installation Locations	10-12
TABLE 10-2	Motherboard Serial Port Jumpers J2604 and J2605	10-23
TABLE 11-1	System Unit Replaceable Components	11-3
TABLE A-1	Ultra 30 Physical Specifications	A-1
TABLE A-2	Ultra 30 Electrical Specifications	A-2

TABLE A-3	Ultra 30 Environmental Requirements	A-2
TABLE B-1	Keyboard/Mouse Connector Pin Assignments	B-2
TABLE B-2	Serial Port A and B Connector Pin Assignments	B-3
TABLE B-3	TPE Connector Pin Assignments	B-6
TABLE B-4	UltraSCSI Connector Pin Assignments	B-7
TABLE B-5	Audio Connector Line Assignments	B-10
TABLE B-6	Parallel Port Connector Pin Assignments	B-11
TABLE B-7	MII Connector Pin Assignments	B-13
TABLE B-8	UPA Graphics Card Connector Pin Assignments	B-16
TABLE C-1	UPA Port Identification Assignments	C-4
TABLE C-2	DIMM Pair-To-U Number	C-12
TABLE C-3	Physical Address Map to DIMM Pair (Non-Interleave)	C-12
TABLE C-4	Physical Address Maps to DIMM Pair (Interleave)	C-13
TABLE C-5	Diskette Drive Signals by Mnemonic Name	C-16
TABLE C-6	Supported Hard Drives	C-18
TABLE C-7	Major Features of the Audio Card	C-27
TABLE C-8	SCSI Subsystem Supported Target Devices	C-30
TABLE C-9	Power Supply Output Voltages	C-35
TABLE C-10	Power Supply Control Signals	C-36
TABLE C-11	Power Estimate (3.3-ns CPU Module)	C-37
TABLE C-12	Power Estimate (4-ns CPU Module)	C-38
TABLE C-13	Power Estimate for the 5-Vdc PCI Card	C-38
TABLE C-14	Power Estimate for the 3.3-Vdc PCI Card	C-39
TABLE C-15	Power Estimate for the Memory Subsystem	C-39
TABLE C-16	Power Estimates for the Storage Devices	C-39
TABLE C-17	Built-In Speaker Specifications	C-40
TABLE C-18	Serial Port Jumper Settings	C-44
TABLE C-19	Flash PROM Jumper Settings	C-45

Preface

The *Sun Ultra 30 Service Manual* provides detailed procedures that describe the removal and replacement of replaceable parts in the Ultra™ 30 computer (system unit). This book is written for technicians, system administrators, authorized service providers (ASPs), and advanced computer system end users who have experience troubleshooting and replacing hardware.

How This Book Is Organized

This document is organized into chapters and appendixes as in the following table. A glossary and an index is also included.

TABLE P-1 Document Organization

Chapter Number/Title	Content Description
Chapter 1, "Product Description"	Describes the major components of the system unit.
Chapter 2, "SunVTS Overview"	Describes the execution of individual tests for verifying hardware configuration and functionality.
Chapter 3, "Power-On Self-Test"	Describes the execution of POST and provides examples of POST output patterns.
Chapter 4, "Troubleshooting Procedures"	Provides troubleshooting advice and suggested corrective actions for hardware problems.
Chapter 5, "Safety and Tool Requirements"	Explains how to work safely when servicing the system unit.

TABLE P-1 Document Organization (*Continued*)

Chapter Number/Title	Content Description
Chapter 6, "Power On and Off"	Provides step-by-step procedures to power on and power off the system unit.
Chapter 7, "Internal Access"	Provides step-by-step procedures to remove the side access panel, attach the wrist strap, and replace the side access panel.
Chapter 8, "Major Subassemblies"	Provides step-by-step procedures to remove and replace major subassemblies.
Chapter 9, "Storage Devices"	Provides step-by-step procedures to remove and replace storage devices.
Chapter 10, "Motherboard and Component Replacement"	Provides step-by-step procedures to remove and replace the motherboard, and various components associated with motherboard operation.
Chapter 11, "Illustrated Parts List"	Lists replaceable parts for the system unit.
Appendix A, "Product Specifications"	Provides product specifications, system requirements about power and environment, system unit dimensions, weight, memory mapping, and peripheral component interconnect (PCI) card slot specifications.
Appendix B, "Signal Descriptions"	Provides signal descriptions.
Appendix C, "Functional Description"	Provides functional descriptions for the system unit.
Glossary	Provides a listing of acronyms, terms, and definitions.
Index	Provides a quick reference to specific topics.

UNIX Commands

This document may not contain information on basic UNIXcommands® and procedures.

See one or more of the following for this information:

- *Solaris 2.x Handbook for SMCC Peripherals*
- AnswerBook™ online documentation for the Solaris 2.x software environment
- Other software documentation that you received with your system

Typographic Conventions

TABLE P-2 Typographic Conventions

Typeface or Symbol	Meaning	Examples
AaBbCc123	The names of commands, files, and directories; on-screen computer output.	Edit your <code>.login</code> file. Use <code>ls -a</code> to list all files. % You have mail.
AaBbCc123	What you type, when contrasted with on-screen computer output.	% su Password:
<i>AaBbCc123</i>	Book titles, new words or terms, words to be emphasized. Command-line variable; replace with a real name or value.	Read Chapter 6 in the <i>User's Guide</i> . These are called <i>class</i> options. You <i>must</i> be <i>root</i> to do this. To delete a file, type <code>rm filename</code> .

Shell Prompts

TABLE P-3 Shell Prompts

Shell	Prompt
C shell	<i>machine_name</i> %
C shell superuser	<i>machine_name</i> #
Bourne shell and Korn shell	\$
Bourne shell and Korn shell superuser	#

Related Documents

TABLE P-4 Related Documents

Application	Title	Part Number
Configuration	<i>Sun Ultra 30 System Reference Manual</i>	802-4147
Configuration	<i>Solaris Handbook for SMCC Peripherals</i>	802-7675
Diagnostics	<i>SunVTS 2.0 User's Guide</i>	802-5331
Diagnostics	<i>SunVTS 2.0 Test Reference Manual</i>	802-5330
Diagnostics	<i>SunVTS 2.0 Quick Reference Card</i>	802-5329
Installation	<i>14-Gbyte, 8-mm Tape Drive Installation Manual</i>	802-1849
Installation	<i>Creator Frame Buffer Installation Guide</i>	802-6682
Installation	<i>Creator Installation Guide</i>	802-7731
Installation	<i>Elite3D Installation Guide</i>	805-4391
Installation/User	<i>12-24 Gbyte 4-mm DDS-3 Tape Drive Installation and User's Guide</i>	802-7791
Installation	<i>5.25" Fast/Wide Differential SCSI Disk Drive Installation Manual</i>	802-1653
Specification	<i>Manual Eject Diskette Drive Specifications</i>	805-ii33
Specification	<i>DDS-2 Tape Drive Specifications</i>	802-5324
Specification	<i>17-Inch Entry, 17-Inch Premium, and 20-Inch Premium Color Monitors Specifications</i>	802-6168
Specification	<i>2.1-Gbyte 7200-RPM Disk Drive Specifications</i>	802-7743
Specification	<i>4.2-Gbyte 7200-RPM Disk Drive Specifications</i>	802-7744
Specification	<i>9-Gbyte 7200-RPM Disk Drive Specifications</i>	802-7745
Specification	<i>SunCD 4 Drive Specifications</i>	802-4157
Specification	<i>Diskette Drive Specification</i>	802-6285

TABLE P-4 Related Documents (Continued)

Application	Title	Part Number
Specification	<i>8-mm Tape Drive Specifications</i>	802-5775
Specification	<i>4-mm, DDS-2 Tape Drive Specifications</i>	802-7790
Specification	<i>Manual Eject Diskette Drive Specifications</i>	805-1133
User	<i>SunVTS 2.0 User's Guide</i>	802-5331
User	<i>24-Inch Premium (22.5-inch Viewable) Color Monitor Guide</i>	875-1799
User	<i>14-Gbyte, 8-mm Tape Drive User's Guide</i>	802-1850
User	<i>Ultra Systems Flash PROM Programming Guide</i>	802-3233

Sun Documentation on the Web

The docs.sun.com web site enables you to access Sun technical documentation on the World Wide Web. You can browse the docs.sun.com archive or search for a specific book title or subject at <http://docs.sun.com>

Sun Welcomes Your Comments

We are interested in improving our documentation and welcome your comments and suggestions. You can email your comments to us at smcc-docs@sun.com. Please include the part number of your document in the subject line of your email.

Product Description

The Ultra 30 desktop workstation is a uniprocessor device that uses the family of UltraSPARC™ processors. It supports high-performance processing (UltraSPARC II) and high-performance graphics. Enclosed within a minitower enclosure, the Ultra 30 desktop workstation provides the following:

- Power and cooling requirements for a high-performance processor and graphics
- Modular internal design
- Improved disk, system, memory, and I/O performance and capacity
- Dual-head UltraSPARC port architecture (UPA) graphics capability
- High-performance peripheral component interconnect (PCI) I/O expansion with comparable options to existing SBus options

FIGURE 1-1 illustrates the Ultra 30 desktop workstation. The following sections provide a brief description of the Ultra 30 desktop workstation I/O devices and a detailed overview of the Ultra 30 computer (system unit) features.

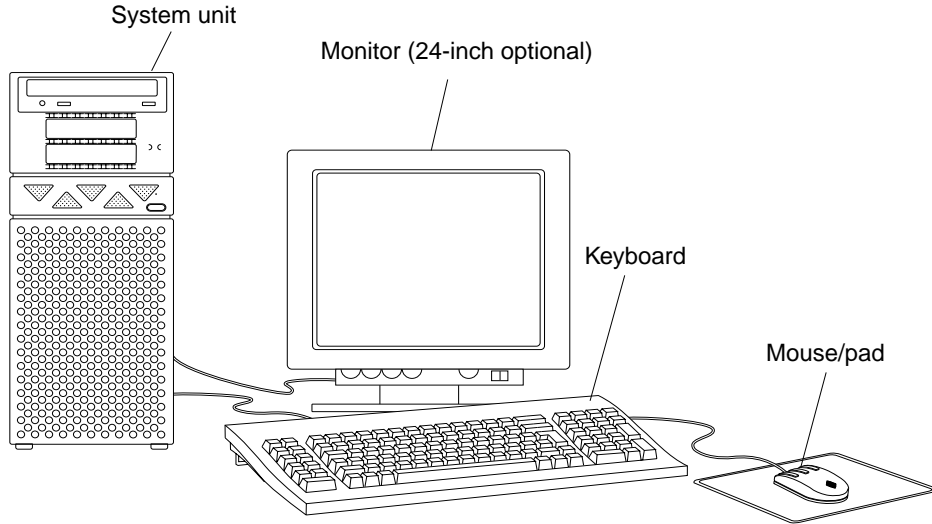

FIGURE 1-1 Sun Ultra 30 Desktop Workstation

1.1 I/O Devices

The Ultra 30 desktop workstation uses the I/O devices as listed in TABLE 1-1.

TABLE 1-1 Supported I/O Devices

I/O Device	Description
21-inch (53-cm) color monitor	1600 x 1000 resolution, 76- or 66-Hz refresh rate
24-inch (61-cm) color monitor	1920 x 1200 resolution, 70-Hz refresh rate
Microphone	SunMicrophone™ II
Keyboard	Sun Type-5; AT 101 or UNIX layout available
Opto-mechanical mouse	Optomechanical, 3-button

1.2 System Unit Features

System unit components are housed in a tower configuration enclosure. Overall enclosure dimensions (width x depth x height) are 17.72 inches (45.00 cm) x 7.50 inches (19.00 cm) x 19.61 inches (49.80 cm). System unit electronics are contained on a single printed circuit board (motherboard). The motherboard contains the CPU module, memory, system control application specific integrated circuits (ASICs), and I/O ASICs.

FIGURE 1-2 illustrates the system unit front view. FIGURE 1-3 illustrates the system unit rear view. System unit electronics and peripherals contain (or may be upgraded to contain) the following features:

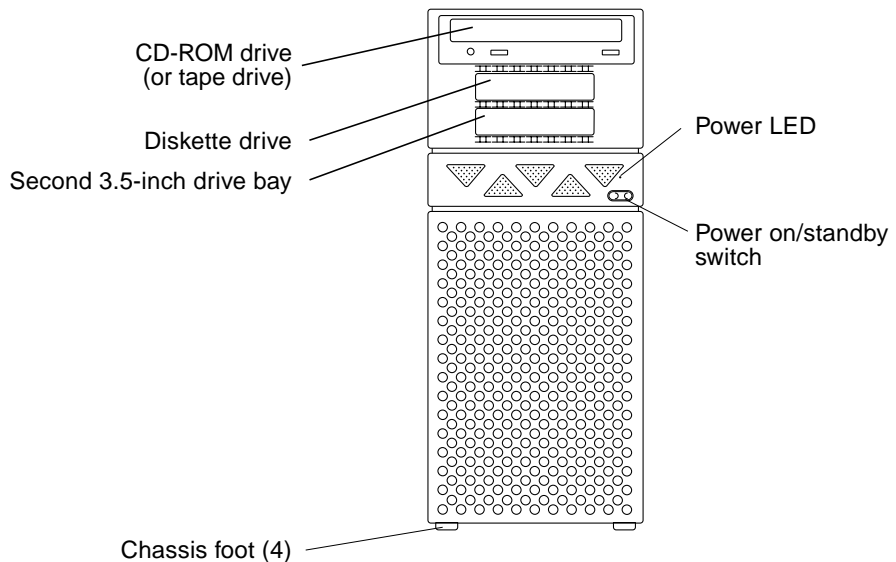

FIGURE 1-2 System Unit Front View

- Tower enclosure with power supply.
- Support for modular UltraSPARC II processor with 1-megabyte (Mbyte) or 2-Mbyte Ecache and system operating frequencies from 100 megahertz (MHz) to 333 MHz.
- UPA coherent memory interconnect.

- Use of dual in-line memory modules (DIMMs), with an interleaved memory system. Each pair of DIMM slots (four rows of two pairs each) accepts 32-, 64-, or 128-Mbyte DIMM modules. Populating with two pair of identical capacity DIMMs enables the memory controller to interleave and overlap, providing the optimal system performance. There are a total of 16 DIMM slots.
- Four PCI slots:
 - Three 33-MHz, 64-bit or 32-bit, 5-Vdc slots
 - One 66-MHz or 33-MHz, 64-bit or 32-bit, 3.3-Vdc slot
- Two UPA graphics slots.
- 10/100-megabits per second Ethernet.
- 40-Mbytes per second UltraSCSI (Fast-20).
- Two DB25 serial ports (synchronous and asynchronous protocols).
- Centronics-compatible parallel port interface with extended capability port (ECP) support.
- Modular audio interface.

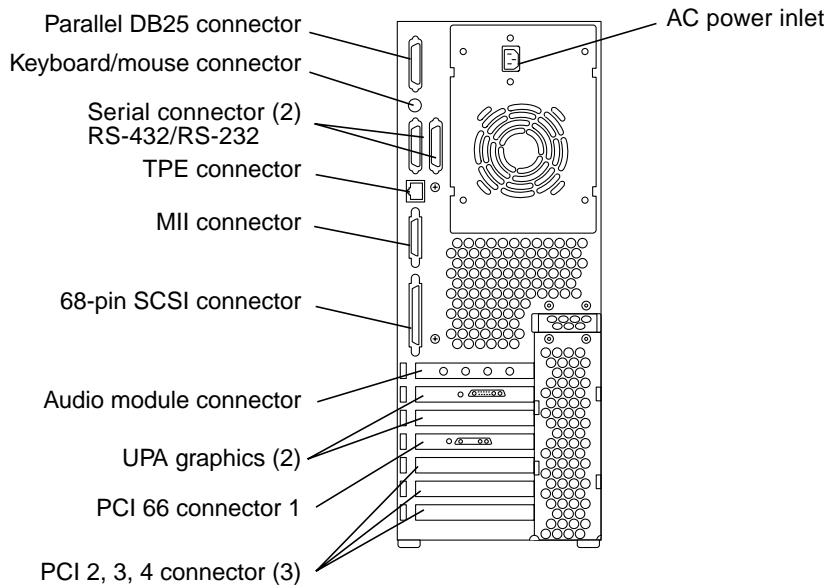

FIGURE 1-3 System Unit Rear View

1.3 System Unit Components

TABLE 1-2 lists the system unit components. A brief description of each listed component is also provided.

Note – Removal and replacement of selected system unit components are also illustrated with photographs and audio/visual instructions on the *Sun Ultra 30 ShowMe How Multimedia Documentation*, part number 704-5681.

Note – Consult your authorized Sun sales representative or service provider prior to ordering a replacement part.

TABLE 1-2 Ultra 30 System Unit Replaceable Components

Component	Description
Motherboard	System board
Hard drive bay with SCSI	Mechanical hard drive housing
2.1-Gbyte SCSI assembly	Hard drive
4.2-Gbyte SCSI assembly	Hard drive
9.1-Gbyte SCSI assembly	Hard drive
PCI fan assembly	PCI fan
Fan assembly	CPU fan
One-piece shroud assembly	Shroud assembly
Two-piece shroud assembly	Shroud assembly
CPU module	250-MHz, 1-Mbyte external cache
CPU module	300-MHz, 2-Mbyte external cache
Graphics card	Vertical, single buffer UPA graphics card, 75-MHz
Graphics card	Vertical, double buffer plus Z (DBZ) UPA graphics card, 75-MHz

TABLE 1-2 Ultra 30 System Unit Replaceable Components *(Continued)*

Component	Description
Graphics card	Vertical, DBZ UPA graphics card, 83-MHz
Graphics card	Vertical, single buffer UPA graphics card, 83-Mhz
Graphics card	Vertical UPA graphics card, 100-MHz, with stereo application
Graphics card	Vertical UPA graphics card, 100-MHz, without stereo application
Power supply	Power supply
Audio module	Audio applications, 16-bit audio, 8 kHz to 48 kHz
Speaker assembly	Speaker
Peripheral cable	Peripheral cable
Diskette drive cable	Diskette drive cable
Manual eject floppy	Diskette drive, 3.5-inch, MS-DOS compatible
EMI filler panel	CD-ROM drive filler panel
EMI filler panel	Diskette drive filler panel
32-Mbyte DIMM	60-ns, 32-Mbyte DIMM
64-Mbyte DIMM	60-ns, 64-Mbyte DIMM
128-Mbyte DIMM	60-ns, 128-Mbyte DIMM
NVRAM/TOD	Time of day, 48T59, with carrier
CD-ROM drive	CD-ROM drive, 1.6-inch height
4-mm tape drive	12-24-Gbyte, 4-mm DDS-2 tape drive
8-mm tape drive	14-Gbyte, 8-mm tape drive
TPE cable (category 5)	Twisted-pair Ethernet cable
DC switch assembly	DC switch assembly
Chassis foot	Chassis foot

SunVTS Overview

This chapter contains an overview of the SunVTS™ diagnostic tool.

This chapter contains the following topics:

- Section 2.1 “SunVTS Description”
- Section 2.2 “SunVTS Operation” on page 2-2

2.1 SunVTS Description

The SunVTS software executes multiple diagnostic hardware tests from a single user interface. SunVTS verifies the configuration, functionality, and reliability of most hardware controllers and devices.

The SunVTS software is used in both the Common Desktop Environment (CDE) and the OPEN LOOK graphical user interface environments, or from a TTY interface.

Within the CDE and OPEN LOOK GUI environments, test parameters are quickly and easily set by pointing and clicking a mouse button.

With a TTY interface, the SunVTS software is used from a terminal or modem attached to a serial port. Data is input through the keyboard, rather than with a mouse, and only one screen of information is displayed at a time.

2.2 SunVTS Operation

TABLE 2-1 lists the documentation for the SunVTS software. These documents are available on the *Solaris on Sun Hardware AnswerBook*, which is on the *SMCC Updates* for the Solaris release.

TABLE 2-1 SunVTS Documentation

Title	Part Number	Description
<i>SunVTS User's Guide</i>	802-7299	Describes the SunVTS environment; starting and controlling various user interfaces; feature descriptions
<i>SunVTS Test Reference Manual</i>	802-7300	Describes each SunVTS test; provides various test options and command line arguments
<i>SunVTS Quick Reference Card</i>	802-7301	Provides overview of vtsui interface features

Power-On Self-Test

This chapter describes how to initiate power-on self-test (POST) diagnostics.

This chapter contains the following topics:

- Section 3.1 “POST Overview” on page 3-1
- Section 3.2 “Pre-POST Preparation” on page 3-2
- Section 3.3 “Initializing POST” on page 3-4
- Section 3.4 “Maximum and Minimum Levels of POST” on page 3-5
- Section 3.5 “POST Progress and Error Reporting” on page 3-18
- Section 3.6 “Bypassing POST” on page 3-20
- Section 3.7 “Additional Keyboard Control Commands” on page 3-20
- Section 3.8 “System and Keyboard LEDs” on page 3-20
- Section 3.9 “Motherboard Test” on page 3-21

3.1 POST Overview

POST is useful in determining if a portion of the system unit has failed and should be replaced. POST detects approximately 95 percent of system unit faults and is located in the system board OpenBoot™ PROM (OBP). The setting of two NVRAM variables, the `diag-switch?` and the `diag-level` flag, determine if POST is executed. TABLE 3-1 lists the `diag-switch?` and `diag-level` flag settings for disabling POST (off), enabling POST maximum (max), or enabling POST minimum (min).

Note – With the `diag-level` set to `off` and the `diag-switch?` set to `true`, a serial port A output is enabled, but the output *is not* a POST display.

TABLE 3-1 `diag-switch?` and `diag-level` Flag Settings

<code>diag-level</code> Setting	<code>diag-switch?</code> Setting	POST Initialization	Serial Port A Output
Off	N/A	No	Disabled
N/A	False	No	Disabled
Max	True	Yes (power-on)	Enabled
Min	True	Yes (power-on)	Enabled

3.2 Pre-POST Preparation

Pre-POST preparation includes:

- `tip`Setting up a connection to another workstation or terminal to view POST progress and error messages. See Section 3.2.1 “Setting Up a Tip Connection” on page 3-2.
- Verifying baud rates between a workstation and a monitor or a workstation and a terminal. See Section 3.2.2 “Verifying the Baud Rate” on page 3-4.

If a terminal or a monitor is not connected to serial port A (default port) of a workstation or server to be tested, the keyboard LEDs are used to determine error conditions. See Section 3.8 “System and Keyboard LEDs” on page 3-20.

3.2.1 Setting Up a Tip Connection

A `tip` connection enables a remote shell window to be used as a terminal to display test data of a system being tested. Serial port A or serial port B of a tested system unit is used to establish the `tip` connection between the system unit being tested and another Sun™ workstation monitor or TTY-type terminal. The `tip` connection is used in a SunOS™ window and provides features to help with the OBP.

To set up a `tip` connection:

1. See FIGURE 3-1. Connect serial port A of the system being tested to another Sun workstation serial port B using a serial null modem cable (connect cable pins 2-3, 3-2, 7-20, and 20-7).

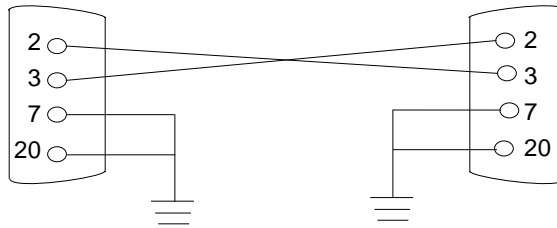

FIGURE 3-1 Setting Up a tip Connection

2. At the other Sun workstation, check the `/etc/remote` file by changing the directory to `/etc` and then editing the `remote` file:

```
hardware:/ dv=/dev/term/b:br#9600:el=^C^S^Q^U^D:ie=%$:oe=^D:
```

Note – The example shows connection to serial port B.

3. To use serial port A:
 - a. Copy and paste the serial port B `remote` file.
 - b. Modify the serial port B `remote` file as follows:

```
hardware:/ dv=/dev/term/a:br#9600:el=^C^S^Q^U^D:ie=%$:oe=^D:
```

4. In a shell window on the Sun workstation, type `tip hardware`.

```
hostname% tip hardware
connected
```

Note – The shell window is now a `tip` window directed to the serial port of the system unit being tested. When power is applied to the system unit being tested, POST messages will be displayed in this window.

5. When POST is completed, disconnect the `tip` window as follows:
 - a. Open a shell window.

- b. Type `ps -a` to view the active `tip` line and process ID (PID) number.
- c. Type the following to kill the `tip` hardware process.

```
hostname% kill -9 PID# of tip hardware process
```

3.2.2 Verifying the Baud Rate

To verify the baud rate between the system unit being tested and a terminal or another Sun workstation monitor:

1. Open a shell window.
2. Type `eeeprom`.
3. Verify the following serial port default settings as follows:

```
ttyb-mode = 9600,8,n,1  
ttya-mode = 9600,8,n,1
```

Note – Ensure that the settings are consistent with TTY-type terminal or workstation monitor settings.

3.3 Initializing POST

POST is initialized in two ways:

- By setting the `diag-switch?` to `true` and the `diag-level` to `max` or `min`, followed by power cycling the system unit
- By simultaneously pressing the Type-5 keyboard Stop and D keys while power is applied to the system unit and the `diag-level` setting is set to either `min` or `max`

To set the `diag-switch?` to `true` and power cycle the system unit:

1. At the system prompt, type:

```
ok setenv diag-switch? true
```

2. At the keyboard, power cycle the system unit by simultaneously pressing the Shift key and the Power-on key (FIGURE 3-2). After a few seconds, press the Power-on key again.

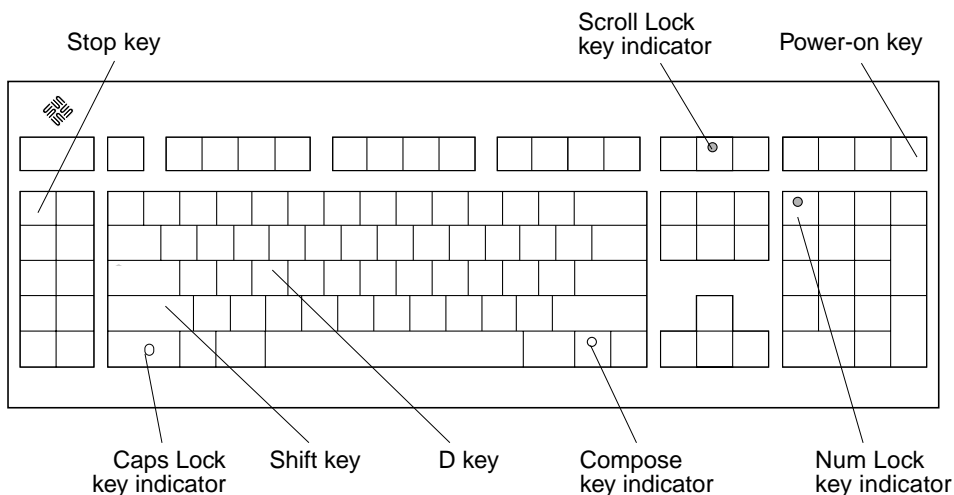

FIGURE 3-2 Sun Type-5 Keyboard

3. Verify the following:

1. The display prompt disappears.
2. The monitor power-on indicator flashes on and off.
3. The keyboard Caps Lock key indicator flashes on and off.

- When POST is complete, type the following at the system prompt:

```
ok setenv diag-switch? false
```

3.4 Maximum and Minimum Levels of POST

Two levels of POST are available: maximum (max) level and minimum (min) level. The system initiates the selected level of POST based upon the setting of `diag-level`, a NVRAM variable.

The default setting for `diag-level` is `max`. An example of a `max` level POST output on serial port A is provided in Section 3.4.1 “`diag-level` Variable Set to `max`”. An example of a `min` level POST output on serial port A is provided in Section 3.4.2 “`diag-level` Variable Set to `min`” on page 3-12.

To set the `diag-level` variable to `min`, type:

```
ok setenv diag-level min
```

To return to the default setting:

```
ok setenv diag-level max
```

3.4.1 `diag-level` Variable Set to `max`

When the `diag-level` variable is set to `max`, POST enables an extended set of diagnostic-level tests. This mode requires approximately 4 minutes to complete (with 128 Mbytes of DIMM installed). CODE EXAMPLE 3-1 identifies a typical serial port A POST output with the `diag-level` variable set to `max`.

CODE EXAMPLE 3-1 `diag-level` Variable Set to `max`

```
Executing Power On SelfTest

@(#) Sun Ultra 30 UPA/PCI POST 1.1.1 03/04/97

CPU: UltraSPARC 2 (MHz: 296 MID: 0 Ecache Size: 2048KB)
Init System BSS
NVRAM Battery Detect Test
NVRAM Scratch Addr Test
NVRAM Scratch Data Test
M48T59 TOD Timestamp Test
M48T59 TOD Init Test
M48T59 TOD Functional Test
DMMU TLB Tag Access Test
DMMU TLB RAM Access Test
Probe Ecache
Ecache RAM Addr Test
Ecache Tag Addr Test
Invalidate Ecache Tags
Init SC Regs
SC Address Reg Test
SC Reg Index Test
```

CODE EXAMPLE 3-1 diag-level Variable Set to max (Continued)

```
SC Regs Test
Init SC Regs
Probe Memory
INFO:      0MB Bank 0
INFO:      0MB Bank 1
INFO:      0MB Bank 2
INFO:      0MB Bank 3
INFO:      0MB Bank 4
INFO:      0MB Bank 5
INFO:      64MB Bank 6
INFO:      64MB Bank 7
Interleave Mode Enable
Malloc Post Memory
Init Post Memory
Memory Addr w/ Ecache Test
Map PROM/STACK/NVRAM in DMMU
Update Master Stack/Frame Ptrs
V9 Instruction Test
CPU Tick and Tick Compare Reg Test
CPU Soft Trap Test
CPU Softint Reg and Int Test
FPU Regs Test
FPU Move Regs Test
FPU State Reg Test
FPU Functional Test
FPU Trap Test
DMMU Primary Context Reg Test
DMMU Secondary Context Reg Test
DMMU TSB Reg Test
DMMU Tag Access Reg Test
DMMU VA Watchpoint Reg Test
DMMU PA Watchpoint Reg Test
IMMU TSB Reg Test
IMMU Tag Access Reg Test
IMMU TLB RAM Access Test
IMMU TLB Tag Access Test
Dcache RAM Test
Dcache Tag Test
Icache RAM Test
Icache Tag Test
Icache Next Test
Icache Predecode Test
Displacement Flush Ecache
Ecache RAM Test
Ecache Tag Test
Ecache Access Test
```

CODE EXAMPLE 3-1 diag-level Variable Set to max (Continued)

```
Init Psycho
Psycho Cntl and UPA Reg Test
Psycho DMA Scoreboard Reg Test
Psycho Perf Cntl Reg Test
PIO Decoder and BCT Test
PCI Byte Enable Test
Counter/Timer Limit Regs Test
Timer Increment Test
Timer Reload Test
Timer Periodic Test
Mondo Int Map (short) Reg Test
Mondo Int Set/Clr Reg Test
Psycho IOMMU Regs Test
Psycho IOMMU RAM NTA Test
Psycho IOMMU CAM NTA Test
Psycho IOMMU RAM Address Test
Psycho IOMMU CAM Address Test
IOMMU TLB Compare Test
IOMMU TLB Flush Test
Stream Buff A Control Reg Test
Psycho ScacheA Page Tag Addr Test
Psycho ScacheA Line Tag Addr Test
Psycho ScacheA RAM Addr Test
Psycho ScacheA Page Tag NTA Test
Psycho ScacheA Line Tag NTA Test
Psycho ScacheA Error Status NTA Test
Psycho ScacheA RAM NTA Test
Stream Buff B Control Reg Test
Psycho ScacheB Page Tag Addr Test
Psycho ScacheB Line Tag Addr Test
Psycho ScacheB RAM Addr Test
Psycho ScacheB Page Tag NTA Test
Psycho ScacheB Line Tag NTA Test
Psycho ScacheB Error Status NTA Test
Psycho ScacheB RAM NTA Test
PBMA PCI Config Space Regs Test
PBMA Control/Status Reg Test
PBMA Diag Reg Test
PBMB PCI Config Space Regs Test
PBMB Control/Status Reg Test
PBMB Diag Reg Test
Init Memory
INFO:      0MB Bank 0
INFO:      0MB Bank 1
INFO:      0MB Bank 2
INFO:      0MB Bank 3
```

CODE EXAMPLE 3-1 diag-level Variable Set to max (Continued)

```
INFO:      0MB Bank 4
INFO:      0MB Bank 5
INFO:      64MB Bank 6
INFO:      64MB Bank 7
Memory RAM Test
INFO:      0MB Bank 0
INFO:      0MB Bank 1
INFO:      0MB Bank 2
INFO:      0MB Bank 3
INFO:      0MB Bank 4
INFO:      0MB Bank 5
INFO:      64MB Bank 6
INFO:      64MB Bank 7
Memory Addr w/ Ecache Test
INFO:      0MB Bank 0
INFO:      0MB Bank 1
INFO:      0MB Bank 2
INFO:      0MB Bank 3
INFO:      0MB Bank 4
INFO:      0MB Bank 5
INFO:      64MB Bank 6
INFO:      64MB Bank 7
Block Memory Addr Test
INFO:      0MB Bank 0
INFO:      0MB Bank 1
INFO:      0MB Bank 2
INFO:      0MB Bank 3
INFO:      0MB Bank 4
INFO:      0MB Bank 5
INFO:      64MB Bank 6
INFO:      64MB Bank 7
Displacement Flush Ecache Test
ECC Memory Addr Test
INFO:      0MB Bank 0
INFO:      0MB Bank 1
INFO:      0MB Bank 2
INFO:      0MB Bank 3
INFO:      0MB Bank 4
INFO:      0MB Bank 5
INFO:      64MB Bank 6
INFO:      64MB Bank 7
DMMU Hit/Miss Test
IMMU Hit/Miss Test
DMMU Little Endian Test
IU ASI Access Test
FPU ASI Access Test
```

CODE EXAMPLE 3-1 diag-level Variable Set to max (Continued)

```
Ecache Thrash Test
UltraSPARC-2 Prefetch Instructions Test
CPU UPA Config: 000006b6.3cc0803b
SRAM Mode: 22 Clock Mode: 3:1 ELIM: 3 PCON: 0f3 MCAP: 13
Ecache Size Limited: 2048KB
Test 0: prefetch_mr
Test 1: prefetch to non-cacheable page
Test 2: prefetch to page with dmmu miss
Test 3: prefetch miss does not check alignment
Test 4: prefetcha with asi 0x4c is noped
Test 5: prefetcha with asi 0x54 is noped
Test 6: prefetcha with asi 0x6e is noped
Test 7: prefetcha with asi 0x76 is noped
Test 8: prefetch with fcn 5
Test 9: prefetch with fcn 2
Test 10: prefetch with fcn 12
Test 11: prefetch with fcn 16 is noped
Test 12: prefetch with fcn 29 is noped
Test 13: prefetcha with asi 0x15 is noped
Test 14: prefetch with fcn 3
Test 15: prefetcha14 with fcn 2
Test 16: prefetcha80_mr
Test 17: prefetcha81_lr
Test 18: prefetcha10_mw
Test 19: prefetcha80_17 is noped
Test 20: prefetcha10_6: illegal instruction trap
Test 21: prefetcha11_lw
Test 22: prefetcha81_31
Test 23: prefetcha11_15: illegal instruction trap
Init Psycho
Mondo Generate Interrupt Test
Timer Interrupt Test
Timer Interrupt w/ periodic Test
Psycho Stream Buff A Flush Sync Test
Psycho Stream Buff B Flush Sync Test
Psycho Stream Buff A Flush Invalidate Test
Psycho Stream Buff B Flush Invalidate Test
Psycho Merge Buffer w/ Scache A Test
Psycho Merge Buffer w/ Scache B Test
Consist DMA Rd, IOMMU miss Ebus Test
Consist DMA Rd, IOMMU miss Lpbk Test
Consist DMA Rd, IOMMU hit Ebus Test
Consist DMA Rd, IOMMU hit Lpbk Test
Consist DMA Wr, IOMMU miss Ebus Test
Consist DMA Wr, IOMMU miss Lpbk Test
Consist DMA Wr, IOMMU hit Ebus Test
```

CODE EXAMPLE 3-1 diag-level Variable Set to max (Continued)

```
Consist DMA Wr, IOMMU hit Lpbk Test
Stream DMA Rd, IOMMU miss, Scache Miss Ebus Test
Stream DMA Rd, IOMMU miss, Scache Miss Lpbk Test
Stream DMA Rd, IOMMU hit, Scache Miss Ebus Test
Stream DMA Rd, IOMMU hit, Scache Miss Lpbk Test
Stream DMA Rd, IOMMU Miss, Scache(prev rd) Hit Ebus Test
Stream DMA Rd, IOMMU Miss, Scache Hit (prev rd) Lpbk Test
Stream DMA Rd, IOMMU Hit, Scache Hit Ebus Test
Stream DMA Rd, IOMMU Hit, Scache Hit (prev rd) Lpbk Test
Stream DMA Rd, IOMMU Miss, Scache Hit(prev wr) Ebus Test
Stream DMA Rd, IOMMU Miss, Scache Hit (prev wr) Lpbk Test
Stream DMA Rd, IOMMU Hit, Scache Hit(prev wr) Ebus Test
Stream DMA Rd, IOMMU Hit, Scache Hit (prev wr) Lpbk Test
Stream DMA Wr, IOMMU miss, Scache Miss Ebus Test
Stream DMA Wr, IOMMU miss, Scache Miss Lpbk Test
Stream DMA Wr, IOMMU hit, Scache Miss Ebus Test
Stream DMA Wr, IOMMU hit, Scache Miss Lpbk Test
Stream DMA Wr, IOMMU Miss, Scache(prev rd) Hit Ebus Test
Stream DMA Wr, IOMMU Miss, Scache(prev rd) Hit Lpbk Test
Stream DMA Wr, IOMMU Hit, Scache(prev rd) Hit Ebus Test
Stream DMA Wr, IOMMU Hit, Scache(prev rd) Hit Lpbk Test
Stream DMA Wr, IOMMU Miss, Scache(prev wr) Hit Ebus Test
Stream DMA Wr, IOMMU Miss, Scache(prev wr) Hit Lpbk Test
Stream DMA Wr, IOMMU Hit, Scache(prev wr) Hit Ebus Test
Stream DMA Wr, IOMMU Hit, Scache(prev wr) Hit Lpbk Test
Pass-Thru DMA Rd, Ebus device Test
Pass-Thru DMA Wr, Ebus device Test
Consist DMA Rd, IOMMU LRU Lock Ebus Test
Consist DMA Rd, IOMMU LRU Lock Lpbk Test
Stream DMA Rd, IOMMU LRU Lock, Scache LRU Lock Ebus Test
Stream DMA Rd, IOMMU LRU Lock, Scache LRU Lock Lpbk Test
Stream DMA Rd, IOMMU miss, Scache LRU Lock Ebus Test
Stream DMA Rd, IOMMU Miss, Scache LRU Lock Lpbk Test
Stream DMA Rd, IOMMU Hit, Scache LRU Lock Ebus Test
Stream DMA Rd, IOMMU Hit, Scache LRU Lock Lpbk Test
Stream DMA Rd, IOMMU LRU Lock, Scache Miss Ebus Test
Stream DMA Rd, IOMMU LRU Lock, Scache Miss Lpbk Test
Consist DMA Wr, IOMMU LRU Locked Ebus Test
Consist DMA Wr, IOMMU LRU Lock Lpbk Test
Stream DMA Wr, IOMMU LRU Lock, Scache LRU Lock Ebus Test
Stream DMA Wr, IOMMU LRU Lock, Scache LRU Lock Lpbk Test
Stream DMA Wr, IOMMU Miss, Scache LRU Lock Ebus Test
Stream DMA Wr, IOMMU Miss, Scache LRU Lock Lpbk Test
Stream DMA Wr, IOMMU Hit, Scache LRU Lock Ebus Test
Stream DMA Wr, IOMMU Hit, Scache LRU Lock Lpbk Test
Stream DMA Wr, IOMMU LRU Lock, Scache Miss Ebus Test
```

CODE EXAMPLE 3-1 diag-level Variable Set to max (Continued)

```
Stream DMA Wr, IOMMU LRU Lock, Scache Miss Lpbk Test
Stream DMA Wr, IOMMU LRU Lock, Scache(prev rd) Hit Ebus Test
Stream DMA Wr, IOMMU LRU Lock, Scache(prev rd) Hit Lpbk Test
CPU Addr Align Trap Test
DMMU Access Priv Page Test
DMMU Write Protected Page Test
Init Psycho
PIO Read Error, Master Abort Test
PIO Read Error, Target Abort Test
PIO Write Error, Master Abort Test
PIO Write Error, Target Abort Test
Pri CE ECC Error Test
Pri UE ECC Error Test
Pri 2 bit w/ bit hole UE ECC Err Test
Pri 3 bit UE ECC Err Test
STATUS =PASSED

Power On Selftest Completed
```

3.4.2 diag-level Variable Set to min

CODE EXAMPLE 3-2 diag-level Variable Set to min

```
Executing Power On SelfTest

@(#) Sun Ultra 30 UPA/PCI POST 1.1.1 03/04/97

CPU: UltraSPARC 2 (MHz: 296 MID: 0 Ecache Size: 2048KB)
Init System BSS
NVRAM Battery Detect Test
NVRAM Scratch Addr Test
NVRAM Scratch Data Test
M48T59 TOD Timestamp Test
M48T59 TOD Init Test
M48T59 TOD Functional Test
DMMU TLB Tag Access Test
DMMU TLB RAM Access Test
Probe Ecache
Ecache RAM Addr Test
Ecache Tag Addr Test
Invalidate Ecache Tags
Init SC Regs
```

CODE EXAMPLE 3-2 diag-level Variable Set to min (Continued)

```
SC Address Reg Test
SC Reg Index Test
SC Regs Test
Init SC Regs
Probe Memory
INFO:      0MB Bank 0
INFO:      0MB Bank 1
INFO:      0MB Bank 2
INFO:      0MB Bank 3
INFO:      0MB Bank 4
INFO:      0MB Bank 5
INFO:      64MB Bank 6
INFO:      64MB Bank 7
Interleave Mode Enable
Malloc Post Memory
Init Post Memory
Memory Addr w/ Ecache Test
Map PROM/STACK/NVRAM in DMMU
Update Master Stack/Frame Ptrs
V9 Instruction Test
CPU Soft Trap Test
CPU Softint Reg and Int Test
FPU Regs Test
FPU Move Regs Test
DMMU Primary Context Reg Test
DMMU Secondary Context Reg Test
DMMU TSB Reg Test
DMMU Tag Access Reg Test
IMMU TSB Reg Test
IMMU Tag Access Reg Test
Dcache Tag Test
Icache Tag Test
Displacement Flush Ecache
Ecache RAM Test
Ecache Tag Test
Ecache Access Test
Init Psycho
Psycho Cntl and UPA Reg Test
Psycho DMA Scoreboard Reg Test
Counter/Timer Limit Regs Test
Mondo Int Map (short) Reg Test
Psycho IOMMU Regs Test
Psycho IOMMU RAM Address Test
Psycho IOMMU CAM Address Test
Psycho ScacheA RAM Addr Test
Psycho ScacheB RAM Addr Test
```

CODE EXAMPLE 3-2 diag-level Variable Set to min (Continued)

```
PBMA PCI Config Space Regs Test
PBMA Control/Status Reg Test
PBMB PCI Config Space Regs Test
PBMB Control/Status Reg Test
Init Memory
INFO:      0MB Bank 0
INFO:      0MB Bank 1
INFO:      0MB Bank 2
INFO:      0MB Bank 3
INFO:      0MB Bank 4
INFO:      0MB Bank 5
INFO:      64MB Bank 6
INFO:      64MB Bank 7
Memory Addr w/ Ecache Test
INFO:      0MB Bank 0
INFO:      0MB Bank 1
INFO:      0MB Bank 2
INFO:      0MB Bank 3
INFO:      0MB Bank 4
INFO:      0MB Bank 5
INFO:      64MB Bank 6
INFO:      64MB Bank 7
IU ASI Access Test
FPU ASI Access Test
Ecache Thrash Test
~~~x|`Hardware Power On`Button Power ON
SCUPP detected
Configuring SCUP for 84.0-100.0 Mhz
@(#) Sun Ultra 30 UPA/PCI 3.11 Version 1 created 1997/12/03 16:46
Probing keyboard Done
%o0 = 0000.0000.0000.2001

Executing Power On SelfTest

@(#) Sun Ultra 30 UPA/PCI POST 1.1.1 03/04/97

CPU: UltraSPARC 2 (MHz: 296 MID: 0 Ecache Size: 2048KB)
Init System BSS
NVRAM Battery Detect Test
NVRAM Scratch Addr Test
NVRAM Scratch Data Test
M48T59 TOD Timestamp Test
M48T59 TOD Init Test
M48T59 TOD Functional Test
DMMU TLB Tag Access Test
DMMU TLB RAM Access Test
```

CODE EXAMPLE 3-2 diag-level Variable Set to min (Continued)

```
Probe Ecache
Ecache RAM Addr Test
Ecache Tag Addr Test
Invalidate Ecache Tags
Init SC Regs
SC Address Reg Test
SC Reg Index Test
SC Regs Test
Init SC Regs
Probe Memory
INFO:      0MB Bank 0
INFO:      0MB Bank 1
INFO:      0MB Bank 2
INFO:      0MB Bank 3
INFO:      0MB Bank 4
INFO:      0MB Bank 5
INFO:      64MB Bank 6
INFO:      64MB Bank 7
Interleave Mode Enable
Malloc Post Memory
Init Post Memory
Memory Addr w/ Ecache Test
Map PROM/STACK/NVRAM in DMMU
Update Master Stack/Frame Ptrs
V9 Instruction Test
CPU Soft Trap Test
CPU Softint Reg and Int Test
FPU Regs Test
FPU Move Regs Test
DMMU Primary Context Reg Test
DMMU Secondary Context Reg Test
DMMU TSB Reg Test
DMMU Tag Access Reg Test
IMMU TSB Reg Test
IMMU Tag Access Reg Test
Dcache Tag Test
Icache Tag Test
Displacement Flush Ecache
Ecache RAM Test
Ecache Tag Test
Ecache Access Test
Init Psycho
Psycho Cntl and UPA Reg Test
Psycho DMA Scoreboard Reg Test
Counter/Timer Limit Regs Test
Mondo Int Map (short) Reg Test
```

CODE EXAMPLE 3-2 diag-level Variable Set to min (Continued)

```
Psycho IOMMU Regs Test
Psycho IOMMU RAM Address Test
Psycho IOMMU CAM Address Test
Psycho ScacheA RAM Addr Test
Psycho ScacheB RAM Addr Test
PBMA PCI Config Space Regs Test
PBMA Control/Status Reg Test
PBMB PCI Config Space Regs Test
PBMB Control/Status Reg Test
Init Memory
INFO:      0MB Bank 0
INFO:      0MB Bank 1
INFO:      0MB Bank 2
INFO:      0MB Bank 3
INFO:      0MB Bank 4
INFO:      0MB Bank 5
INFO:      64MB Bank 6
INFO:      64MB Bank 7
Memory Addr w/ Ecache Test
INFO:      0MB Bank 0
INFO:      0MB Bank 1
INFO:      0MB Bank 2
INFO:      0MB Bank 3
INFO:      0MB Bank 4
INFO:      0MB Bank 5
INFO:      64MB Bank 6
INFO:      64MB Bank 7
IU ASI Access Test
FPU ASI Access Test
Ecache Thrash Test
UltraSPARC-2 Prefetch Instructions Test
CPU UPA Config: 000006b6.3cc0803b
SRAM Mode: 22 Clock Mode: 3:1 ELIM: 3 PCON: 0f3 MCAP: 13
Ecache Size Limited: 2048KB
Test 0: prefetch_mr
Test 1: prefetch to non-cacheable page
Test 2: prefetch to page with dmmu misss
Test 3: prefetch miss does not check alignment
Test 4: prefetcha with asi 0x4c is noped
Test 5: prefetcha with asi 0x54 is noped
Test 6: prefetcha with asi 0x6e is noped
Test 7: prefetcha with asi 0x76 is noped
Test 8: prefetch with fcn 5
Test 9: prefetch with fcn 2
Test 10: prefetch with fcn 12
Test 11: prefetch with fcn 16 is noped
```

CODE EXAMPLE 3-2 diag-level Variable Set to min (*Continued*)

```
Test 12: prefetch with fcn 29 is noped
Test 13: prefetcha with asi 0x15 is noped
Test 14: prefetch with fcn 3
Test 15: prefetcha14 with fcn 2
Test 16: prefetcha80_mr
Test 17: prefetcha81_lr
Test 18: prefetcha10_mw
Test 19: prefetcha80_17 is noped
Test 20: prefetcha10_6: illegal instruction trap
Test 21: prefetcha11_lw
Test 22: prefetcha81_31
Test 23: prefetcha11_15: illegal instruction trap
Init Psycho
Mondo Generate Interrupt Test
CPU Addr Align Trap Test
DMMU Access Priv Page Test
DMMU Write Protected Page Test
Init Psycho
PIO Read Error, Master Abort Test
PIO Read Error, Target Abort Test
PIO Write Error, Master Abort Test
PIO Write Error, Target Abort Test
Pri CE ECC Error Test
Pri UE ECC Error Test
Pri 2 bit w/ bit hole UE ECC Err Test
Pri 3 bit UE ECC Err Test
STATUS =PASSED

Power On Selftest Completed
```

When the `diag-level` variable is set to `min`, POST enables an abbreviated set of diagnostic-level tests. This mode requires approximately 3 minutes to complete. CODE EXAMPLE 3-2 identifies a serial port A POST output with the `diag-level` NVRAM variable set to `min`.

3.5 POST Progress and Error Reporting

While POST is initialized, the Caps Lock key on the Sun Type-5 keyboard flashes on and off to indicate that POST tests are being executed. Additional POST progress indications are also visible when a TTY-type terminal or a `tip` line is connected between serial port A (default port) of the system being tested and a POST monitoring system.

If an error occurs during the POST execution, the keyboard Caps Lock key indicator stops flashing and an error code is displayed using the Caps Lock, Compose, Scroll Lock, and Num Lock key indicators. The error code indicates a particular system hardware failure.

Note – An error code may only be visible for a few seconds. Observe the Caps Lock, Compose, Scroll Lock, and Num Lock key indicators closely while POST is active.

In most cases, POST also attempts to send a failure message to the POST monitoring system. CODE EXAMPLE 3-3 identifies the typical appearance of a failure message. If a keyboard error code is displayed, determine the meaning of the error code by comparing the keyboard error code pattern to the corresponding error code meaning listed in TABLE 3-2 on page 3-19.

Note – The system does not automatically boot if a POST error occurs; it halts at the `ok` prompt to alert the user of a failure.

CODE EXAMPLE 3-3 Typical Error Code Failure Message

```
UltraSPARC-2 Prefetch Instructions Test
CPU UPA Config: 000006b8.3cc0803b
SRAM Mode: 22 Clock Mode: 3:1 ELIM: 4 PCON: 0f3 MCAP: 13
Ecache Size Limited: 2048KB
Test 0: prefetch_mr
STATUS =FAILED
TEST   =UltraSPARC-2 Prefetch Instructions
TTF    =0
PASSES =1
ERRORS =1
SUSPECT=CPU (Basic) U0101
MESSAGE=
Edata Mismatch(T0) Data compare error.
addr      00000000.40802000
```

CODE EXAMPLE 3-3 Typical Error Code Failure Message (*Continued*)

```

expected 00000000
observed 22222222
xor       22222222

```

TABLE 3-2 Keyboard LED Patterns

Caps Lock	Compose	Scroll Lock	Num Lock	Bit Value	Meaning of Pattern
Blink	Off	Off	Off	x000(2)	POST in progress
Off	Off	Off	Off	0000(2)	POST successfully completed
Off	Off	Off	On	0001(2)	DIMMs in slot U0701/U0801 failed
Off	Off	On	Off	0010(2)	DIMMs in slot U0901/U1001 failed
Off	Off	On	On	0011(2)	DIMMs in slot U0702/U0802 failed
Off	On	Off	Off	0100(2)	DIMMs in slot U0902/U1002 failed
Off	On	Off	On	0101(2)	DIMMs in slot U0703/U0803 failed
Off	On	On	Off	0110(2)	DIMMs in slot U0903/U1003 failed
Off	On	On	On	0111(2)	DIMMs in slot U0704/U0804 failed
On	Off	Off	Off	1000(2)	DIMMs in slot U0904/U1004 failed
On	Off	Off	On	1001(2)	System board failed
On	Off	On	Off	1010(2)	No memory found
On	Off	On	On	1011(2)	Reserved
On	On	Off	Off	1100(2)	Reserved
On	On	Off	On	1101(2)	Reserved
On	On	On	Off	1110(2)	Bad CPU
On	On	On	On	1111(2)	Reserved

3.6 Bypassing POST

POST can be disabled and thereby bypassed. To bypass POST:

1. **Prior to powering on the system, press and hold the Stop key on the keyboard (FIGURE 3-2 on page 3-5).**
2. **With the Stop key pressed, turn on the system by pressing the Power-on key.**

3.7 Additional Keyboard Control Commands

- Stop Key

If the `diag-level` is set to either `max` or `min` and the `diag-level switch?` variable is set to `true` and POST is not to be executed when the system is powered on, press and hold the keyboard Stop key and press the keyboard Power-on key.

Note – Press and hold the Stop key for approximately 5 seconds.

- Stop and N Keys

To set the system NVRAM parameters to the original default settings, press and hold the Stop and N keys before powering on the system. Continue to hold the Stop and N keys until the system banner displays on the monitor.

3.8 System and Keyboard LEDs

The power light-emitting diode (LED), located at the chassis front, remains lighted when the system is operating normally. FIGURE 1-2 on page 1-3 shows the location of the power LED.

While POST is executing and making progress, the Caps Lock key LED blinks while the rest of the LEDs are off. If POST finds an error, a pattern is encoded in the LEDs to indicate the defective part. If POST completes with no errors, all LEDs will be

turned off before returning to the OpenBoot PROM (OBP). TABLE 3-2 on page 3-19 defines the keyboard LED patterns. FIGURE 3-2 on page 3-5 shows the location of the LED keys on the keyboard.

3.9 Motherboard Test

To initialize the motherboard POST:

1. **At the keyboard:**
 - a. **With the system unit in power off, simultaneously press and hold the keyboard Stop and D keys.**
 - b. **While holding the Stop and D keys, press the Power-on key.**

Note – There will be no video output while POST is initialized.

Note – If POST output results are to be viewed, a `tip` connection must be set up. See Section 3.2.1 “Setting Up a Tip Connection” on page 3-2.

2. **Verify the keyboard LEDs light to confirm the system is in the POST mode and the keyboard Caps Lock key LED flashes on and off to indicate the system has enabled the POST.**
3. **If a failure occurs during POST, a keyboard key LED other than the Caps Lock key LED may light, indicating a failed system component.**
See Section 3.8 “System and Keyboard LEDs” on page 3-20.
4. **If the Caps Lock key LED fails to flash after the Stop and D keys are pressed, POST has failed.**
See Section 3.8 “System and Keyboard LEDs” on page 3-20.

Note – The most probable cause of this type of failure is the motherboard. However, optional system components could also cause POST to fail.

5. **Before replacing the motherboard, remove any optional components, such as PCI cards and memory, and repeat the POST.**

Note – Non-optional components such as four DIMMs in slots U0704, U0804, U0904, and U1004; the motherboard; the power supply; and the keyboard must be installed for POST to execute properly. Removing the optional system components and retesting the system unit isolates the possibility that those components are the cause of the failure.

- 6. To receive additional POST failure information, establish a tip connection.**
See Section 3.2.1 “Setting Up a Tip Connection” on page 3-2.

Troubleshooting Procedures

This chapter describes how to troubleshoot possible hardware problems and includes suggested corrective actions.

- Section 4.1 “Power-On Failure” on page 4-1
- Section 4.2 “Video Output Failure” on page 4-2
- Section 4.3 “Hard Drive or CD-ROM Drive Failure” on page 4-3
- Section 4.4 “Power Supply Test” on page 4-4
- Section 4.5 “DIMM Failure” on page 4-6
- Section 4.6 “OpenBoot PROM On-Board Diagnostics” on page 4-7
- Section 4.7 “OpenBoot Diagnostics” on page 4-12

4.1 Power-On Failure

This section provides examples of power-on failure symptoms and suggested actions.

Symptom

The system unit does not power up when the keyboard power switch is pressed.

Action

Check the keyboard connection. Ensure that the keyboard is properly connected to the system unit. Check the AC power cord. Ensure that the AC power cord is properly connected to the system unit and to the wall receptacle. Verify that the wall receptacle is supplying AC power to the system unit.

Press the power switch. If the system unit powers on, the keyboard may be defective or the system unit is unable to accept the keyboard power-on signal. Power off the system unit and press the keyboard Power-on switch again. If the system unit powers on, no further action is required. If the system unit does not power on, the

CPU module may not be properly seated. Inspect the CPU module for proper seating. If the system unit powers on, no further action is required. If the system unit does not power on, the keyboard may be defective. Connect a spare Sun Type-5 keyboard to the system unit and press the Power-on key.

If the wall receptacle AC power has been verified, the CPU module is properly seated, and a spare Sun Type-5 keyboard has been connected to the system unit and the Power-on key has been pressed but the system unit does not power up, the system unit power supply may be defective. See Section 4.4 “Power Supply Test” on page 4-4.

Symptom

The system unit attempts to power up but does not boot or initialize the monitor.

Action

Press the keyboard Power-on key and watch the keyboard. The keyboard LEDs should light briefly and a tone from the keyboard should be heard. If a tone is not heard or if the keyboard LEDs do not light briefly, the system unit power supply may be defective. See Section 4.4 “Power Supply Test” on page 4-4. If a keyboard tone is heard and the keyboard LEDs light briefly but the system unit still fails to initialize, see Section 3.9 “Motherboard Test” on page 3-21.

4.2 Video Output Failure

This section provides a video output failure symptom and suggested actions.

Symptom

No video at the system monitor.

Action

Check the monitor AC power cord. Ensure that the AC power cord is connected to the monitor and to the wall receptacle. Verify that the wall receptacle is supplying AC power to the monitor. Check the video cable connection between the monitor and the system graphics card output port at the rear of the system. Check that the CPU module is properly seated. If the AC connection to the monitor is correct, the video cable is correctly connected, and the CPU module is properly seated, the system monitor or the system graphics card may be defective. Replace the monitor or the UPA graphics card.

4.3 Hard Drive or CD-ROM Drive Failure

This section provides hard drive and CD-ROM drive failure symptoms and suggested actions.

Symptom

A hard drive read, write, or parity error is reported by the operating system or customer application.

A CD-ROM drive read error or parity error is reported by the operating system or customer application.

Action

Replace the drive indicated by the failure message. The operating system identifies the internal drives as listed in TABLE 4-1.

TABLE 4-1 Internal Drives Identification

Operating System Address	Drive Physical Location and Target
c0t0d0s#	Lower hard disk, target 0
c0t1d0s#	Upper hard disk, target 1
c0t6d0s#	CD-ROM drive, target 6 (optional)
c0t5d0s#	Tape drive, target 5 (optional)

Note – The # symbol in the operating system address examples is a numeral between 0 and 7 that describes the slice or partition on the drive.

Symptom

Hard drive or CD-ROM drive fails to respond to commands.

Note – To bypass POST, type: `setenv diag-switch? false` at the `ok` prompt.

Action

Test the drive response to the `probe-scsi` command as follows:

- **At the system `ok` prompt:**
 - a. **Type** `reset-all`.

b. Type `probe-scsi`.

If the hard drive responds correctly to `probe-scsi`, the message identified in CODE EXAMPLE 4-7 on page 4-11 is displayed. If the drives respond and a message is displayed, the system SCSI controller has successfully probed the devices. This is an indication that the motherboard is operating correctly. If one drive does not respond to the SCSI controller probe but the other does, replace the unresponsive drive. If one hard drive is configured with the system and the `probe-scsi` test fails to show the device in the message, replace the drive. If the problem is still evident after replacing the hard drive, replace the SCSI drive bay (see Section 8.3 “Hard Drive Bay With SCSI Assembly” on page 8-7). If replacing both the hard drive and the SCSI drive bay does not correct the problem, replace the motherboard.

4.4 Power Supply Test

The section describes how to test the power supply. FIGURE 4-1 and TABLE 4-2 identify power supply connector J2901. FIGURE 4-2 and TABLE 4-3 identify power supply connector J2902. FIGURE 4-3 and TABLE 4-4 identify power supply connector J2903.

1. Power off the system unit.

See Section 6.2 “Powering Off the System Unit” on page 6-3.

2. Remove the side access cover.

See Section 7.1 “Removing the Side Access Cover” on page 7-1.

3. Slide the power supply from the chassis enough to expose connectors J2901 through J2903.

4. Power on the system.

5. Using a digital voltage meter (DVM), check the power supply output voltages as follows:

Note – Power supply connectors J2901 through J2903 must remain connected to the motherboard.

a. With the negative probe of the DVM placed on a connector ground (Gnd) pin, position the positive probe on each power pin.

b. Verify voltage and signal availability as listed in Tables 4-2 through 4-4.

6. If any power pin signal is not present with the power supply active and properly connected to the motherboard, replace the power supply.

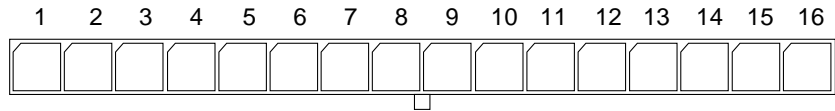

FIGURE 4-1 Power Supply Connector J2901

TABLE 4-2 Power Supply Connector J2901 Pin Assignments

Pin	Description	Pin	Description
1	Rtn	9	SUPPLY TRIP L
2	+3.3 Vdc SENSE	10	POWERON L
3	Rtn	11	-12 Vdc
4	+5.0 Vdc SENSE	12	POWER OK
5	POWER SET0 NEG	13	Gnd
6	+3.0 Vdc SENSE	14	+12 Vdc
7	POWER 0V	15	Rtn
8	POWER SET0 POS	16	+12 Vdc

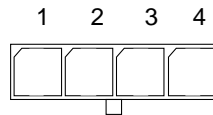

FIGURE 4-2 Power Supply Connector J2902

TABLE 4-3 Power Supply Connector J2902 Pin Assignments

Pin	Description	Pin	Description
1	+5.0 Vdc Rtn	3	+3.3 Vdc Rtn
	+5.0 Vdc Rtn		+3.3 Vdc Rtn
2	+5.0 Vdc	4	+3.3 Vdc
	+5.0 Vdc		+3.3 Vdc

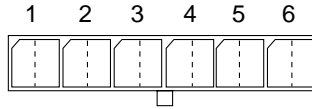

FIGURE 4-3 Power Supply Connector J2903

TABLE 4-4 Power Supply Connector J2903 Pin Assignments

Pin	Function	Pin	Function
1	+3.3 Vdc Rtn	4	+3.3 Vdc
2	+3.3 Vdc Rtn	5	+3.3 Vdc
3	+3.3 Vdc Rtn	6	+3.3 Vdc

4.5 DIMM Failure

At times, the operating system, diagnostic program, or POST may not display a DIMM location (U number) as part of a memory error message. In this situation, the only available information is a physical memory address and failing byte (or bit). Physical memory addresses to locate a defective DIMM are listed in TABLE 4-5.

TABLE 4-5 DIMM Physical Memory Addresses

DIMM Slot	DIMM Pair (non-interleave)	DIMM Quad (interleave)
U701 U801	00000000 - 0ffffff	00000000 - 1ffffff
U901 U1001	10000000 - 1ffffff	
U702 U802	20000000 - 2ffffff	20000000 - 3ffffff
U902 U1002	30000000 - 3ffffff	
U703 U803	40000000 - 4ffffff	40000000 - 5ffffff

TABLE 4-5 DIMM Physical Memory Addresses (*Continued*)

DIMM Slot	DIMM Pair (non-interleave)	DIMM Quad (interleave)
U903 U1003	50000000 - 5ffffff	
U704 U804	60000000 - 6ffffff	60000000 - 7ffffff
U904 U1004	70000000 - 7ffffff	

4.6 OpenBoot PROM On-Board Diagnostics

The following sections describe the OpenBoot PROM (OBP) on-board diagnostics. To execute the OBP on-board diagnostics, the system must be at the `ok` prompt. The OBP on-board diagnostics are listed as follows:

- Section 4.6.1 “`watch-clock`” on page 4-7
- Section 4.6.2 “`watch-net` and `watch-net-all`” on page 4-8
- Section 4.6.3 “`probe-scsi` and `probe-scsi-all`” on page 4-9
- Section 4.6.4 “`test alias name`, `device path`, `-all`” on page 4-10
- Section 4.6.5 “UPA Graphics Card” on page 4-11

4.6.1 `watch-clock`

`watch-clock` reads a register in the NVRAM/TOD chip and displays the result as a seconds counter. During normal operation, the seconds counter repeatedly increments from 0 to 59 until interrupted by pressing any key on the Sun Type-5 keyboard. CODE EXAMPLE 4-1 identifies the `watch-clock` output message.

CODE EXAMPLE 4-1 `watch-clock` Output Message

```
ok watch-clock

Watching the 'seconds' register of the real time clock chip.
It should be 'ticking' once a second.
Type any key to stop.
41 (41 is an example. Counter increments from 0 to 59
```

4.6.2 watch-net and watch-net-all

`watch-net` and `watch-net-all` monitor Ethernet packets on the Ethernet interfaces connected to the system. Good packets received by the system are indicated by a period (.). Errors such as the framing error and the cyclic redundancy check (CRC) error are indicated with an X and an associated error description.

CODE EXAMPLE 4-2 identifies the `watch-net` output message. CODE EXAMPLE 4-3 identifies the `watch-net-all` output message.

CODE EXAMPLE 4-2 watch-net Output Message

```
ok watch-net
Hme register test --- succeeded.
Internal loopback test -- succeeded.
Transceiver check -- Using Onboard Transceiver - Link Up.
passed
Using Onboard Transceiver - Link Up.
Looking for Ethernet Packets.
'.' is a Good Packet. 'X' is a Bad Packet.
Type any key to stop.
.....
ok
```

CODE EXAMPLE 4-3 watch-net-all Output Message

```
ok watch-net-all
/pci@1f,4000/network@1,1
Hme register test --- succeeded.
Internal loopback test -- succeeded.
Transceiver check -- Using Onboard Transceiver - Link Up.
passed
Using Onboard Transceiver - Link Up.
Looking for Ethernet Packets.
'.' is a Good Packet. 'X' is a Bad Packet.
Type any key to stop.
.
ok
```

4.6.3 probe-scsi and probe-scsi-all

`probe-scsi` transmits an inquiry command to internal and external SCSI devices connected to the system unit on-board SCSI interface. If the SCSI device is connected and active, the target address, unit number, device type, and manufacturer name is displayed. `probe-scsi-all` transmits an inquiry command to SCSI devices connected to the system SCSI host adapters. The first identifier listed in the display is the SCSI host adapter address in the system device tree followed by the SCSI device identification data.

CODE EXAMPLE 4-4 identifies the `probe-scsi` output message. CODE EXAMPLE 4-5 identifies the `probe-scsi-all` output message

CODE EXAMPLE 4-4 probe-scsi Output Message

```
ok probe-scsi
This command may hang the system if a Stop-A or halt command
has been executed. Please type reset-all to reset the system
before executing this command.
Do you wish to continue? (y/n) y
Target 0
  Unit 0   Disk      QUANTUM VK2275J SUN2.1G1210
Target 1
  Unit 0   Disk      SEAGATE ST32171W SUN2.1G8254
Target 6
  Unit 0   Removable Read Only device  TOSHIBA XM5701TASUN12XCD0997

ok
```

CODE EXAMPLE 4-5 probe-scsi-all Output Message

```
ok probe-scsi-all
This command may hang the system if a Stop-A or halt command
has been executed. Please type reset-all to reset the system
before executing this command.
Do you wish to continue? (y/n) y
/pci@1f,4000/scsi@3
Target 0
  Unit 0   Disk      QUANTUM VK2275J SUN2.1G1210
Target 1
  Unit 0   Disk      SEAGATE ST32171W SUN2.1G8254
Target 6
  Unit 0   Removable Read Only device  TOSHIBA XM5701TASUN12XCD0997
```

CODE EXAMPLE 4-5 probe-scsi-all Output Message

```
ok
```

4.6.4 test *alias name, device path*, -all

The test command, combined with a device alias or device path, enables a device self-test program. If a device has no self-test program, the message: No selftest method for *device name* is displayed. To enable the self-test program for a device, type the test command followed by the device alias or device path name.

CODE EXAMPLE 4-6 identifies the test output message. TABLE 4-6 lists test *alias name* selections, a description of the selection, and preparation.

Note – The diskette drive (floppy) is selected as the test *alias name* example.

CODE EXAMPLE 4-6 test Output Message

```
ok test floppy

Testing floppy disk system. A formatted disk should be in the
drive.
Test succeeded.

ok
```

TABLE 4-6 Selected OBP On-Board Diagnostic Tests

Type of Test	Description	Preparation
test screen	Tests system video graphics hardware and monitor.	diag-switch? NVRAM parameter must be true for the test to execute.
test floppy	Tests diskette drive response to commands.	A formatted diskette must be inserted into the diskette drive.
test net	Performs internal/external loopback test of the system auto-selected Ethernet interface.	An Ethernet cable must be attached to the system and to an Ethernet tap or hub or the external loopback test fails.

TABLE 4-6 Selected OBP On-Board Diagnostic Tests (*Continued*) (*Continued*)

Type of Test	Description	Preparation
test ttya test ttyb	Outputs an alphanumeric test pattern on the system serial ports: ttya, serial port A; ttyb, serial port B.	A terminal must be connected to the port being tested to observe the output.
test keyboard	Executes the keyboard self-test.	Four keyboard LEDs should flash once and a message is displayed: Keyboard Present.
test -all	Sequentially tests system-configured devices containing self-test.	Tests are sequentially executed in device-tree order (viewed with the <code>show-devs</code> command).

4.6.5 UPA Graphics Card

The UPA graphics card contains a built-in diagnostic test that is enabled through the OBP. The UPA graphics card built-in diagnostic test verifies basic graphics functionality without booting the operating system software.

To execute the built-in diagnostic test, the system must be at the `ok` prompt.

▼ To initialize the UPA graphics card diagnostic:

1. At the `ok` prompt, type:

CODE EXAMPLE 4-7

```
ok setenv diag-switch? true
diag-switch? = true
```

2. At the `ok` prompt, type:

CODE EXAMPLE 4-8

```
ok test screen

Verifying Console Mode for Frame Buffer Board
This will take a few minutes
Verifying Frame Buffer Memory used for console mode
This will take about two minutes
```

CODE EXAMPLE 4-8

```
FFB Frame Buffer functional test passed
ok
```

3. When the UPA graphics card on-board diagnostics are completed, type:**CODE EXAMPLE 4-9**

```
ok setenv diag-switch? false

diag-switch? = false
```

4.7 OpenBoot Diagnostics

The OpenBoot diagnostic (OBDiag) is a menu-driven diagnostic that verifies the system unit's internal I/O system; Ethernet, SCSI, keyboard, mouse, serial port, parallel port, audio, diskette, NVRAM, and PCIO ASIC. OBDiag performs root-cause failure analysis on the referenced devices by testing internal registers, confirming subsystem integrity, and verifying device functionality.

▼ To initialize the OBDiag menu:

1. At the ok prompt, type:**CODE EXAMPLE 4-10**

```
ok setenv mfg-mode on

mfg-mode = on
```

2. At the ok prompt, type:**CODE EXAMPLE 4-11**

```
ok setenv diag-switch? true

diag-switch? = true
```

3. At the ok prompt, type:

CODE EXAMPLE 4-12

```
ok setenv auto-boot? false
auto-boot? = false
```

4. At the ok prompt, type:

CODE EXAMPLE 4-13

```
ok reset-all
```

5. Verify that the platform resets (CODE EXAMPLE 4-14).

CODE EXAMPLE 4-14 Reset Verification

```
ok reset-all
Resetting ...

Software Power ON
SCUPP detected
Configuring SCUP for 84.0-100.0 Mhz
@(#) Sun Ultra 30 UPA/PCI 3.11 Version 1 created 1997/12/03 16:46
Clearing E$ Tags Done
Clearing I/D TLBs Done
Probing Memory
SIMM population : 0000.0000.2200.0000
SIMM esize info : 0000.0000.2200.0000
SIMM msize info : 0000.0000.2200.0000
MEM BASE = 0000.0000.6000.0000
MEM SIZE = 0000.0000.0800.0000
Memory interleave: Enabled
MMUs ON
Copy Done
PC = 0000.01ff.f000.242c
PC = 0000.0000.0000.2470
Decompressing into Memory Done
Size = 0000.0000.0006.d970
ttya initialized
SC Control: EWP:0 IAP:0 FATAL:0 WAKEUP:0 BXIR:0 BPOR:0 SXIR:0
SPOR:1 POR:0
Probing Memory Bank #0  0 +  0 +  0 +  0 :  0 Megabytes
Probing Memory Bank #1  0 +  0 +  0 +  0 :  0 Megabytes
Probing Memory Bank #2  0 +  0 +  0 +  0 :  0 Megabytes
Probing Memory Bank #3 32 + 32 + 32 + 32 : 128 Megabytes
```

CODE EXAMPLE 4-14 Reset Verification (Continued)

```
Probing Floppy: drive detected on ID0
Probing EBUS Nothing there
Probing UPA Slot at 1e,0 SUNW,ffb
Probing UPA Slot at 1d,0 Nothing there
Probing /pci@1f,4000 at Device 1 pci108e,1000 network
Probing /pci@1f,4000 at Device 3 scsi disk tape
Probing /pci@1f,4000 at Device 2 Nothing there
Probing /pci@1f,4000 at Device 4 Nothing there
Probing /pci@1f,4000 at Device 5 Nothing there
Probing /pci@1f,2000 at Device 1 Nothing there
Probing /pci@1f,2000 at Device 2 Nothing there
Sun Ultra 30 UPA/PCI (UltraSPARC-II 296MHz), Keyboard Present
OpenBoot 3.11, 128 MB memory installed, Serial #9097271.
Ethernet address 8:0:20:8a:d0:37, Host ID: 808ad037.
```

```
ok
```

6. At the ok prompt, type: obdiag.

7. Verify that the OBdiag menu is displayed (CODE EXAMPLE 4-15).

CODE EXAMPLE 4-15 OBdiag Menu

```
ok obdiag
stdin: fffefbc8
stdout: fffefbd0
loading code into: /pci@1f,4000/ebus@1
loading code into: /pci@1f,4000/ebus@1/eeeprom
loading code into: /pci@1f,4000/ebus@1/ecpp@14,3043bc
loading code into: /pci@1f,4000/ebus@1/su@14,3062f8
loading code into: /pci@1f,4000/ebus@1/se:a
loading code into: /pci@1f,4000/network@1,1
loading code into: /pci@1f,4000/ebus@1/fdthree@14,3023f0
loading code into: /pci@1f,4000/ebus@1
SUNW,CS4231 Debugging enabled

          OBdiag Menu

0 ..... PCI/Cheerio
1 ..... EBUS DMA/TCR Registers
2 ..... Ethernet
```

CODE EXAMPLE 4-15 OBDiag Menu (*Continued*)

```
3 ..... Keyboard
4 ..... Mouse
5 ..... Floppy
6 ..... Parallel Port
7 ..... Serial Port A
8 ..... Serial Port B
9 ..... NVRAM
10 ..... Audio
11 ..... SCSI
12 ..... All Above
13 ..... Quit
14 ..... Display this Menu
15 ..... Toggle script-debug
16 ..... Enable External Loopback Tests
17 ..... Disable External Loopback Tests

Enter (0-12 tests, 13 -Quit, 14 -Menu) ==>
```

8. At the OBDiag menu prompt, type 15 to enable toggle script-debug messages.

9. At the OBDiag menu prompt, type 17 to disable external loopback tests.

The OBDiag test are listed as follows:

- Section 4.7.1 “PCI/PCIO” on page 4-16
- Section 4.7.2 “EBus DMA/TCR Registers” on page 4-17
- Section 4.7.3 “Ethernet” on page 4-17
- Section 4.7.4 “Keyboard” on page 4-18
- Section 4.7.5 “Mouse” on page 4-19
- Section 4.7.6 “Floppy” on page 4-19
- Section 4.7.7 “Parallel Port” on page 4-20
- Section 4.7.8 “Serial Port A” on page 4-20
- Section 4.7.9 “Serial Port B” on page 4-21
- Section 4.7.10 “NVRAM” on page 4-22
- Section 4.7.11 “Audio” on page 4-23
- Section 4.7.12 “SCSI” on page 4-23
- *Section 4.7.13 “All Above” on page 4-24*

Note – The OBDiag test result data captured in CODE EXAMPLE 4-9 through CODE EXAMPLE 4-22 represent the test result data that is output when the system being tested is connected to a remote shell window through a `tip` connection. When the system being tested is tested in a standalone configuration, the test result data may differ from the test result data captured in CODE EXAMPLE 4-9 through CODE EXAMPLE 4-22.

4.7.1 PCI/PCIO

The PCI/PCIO diagnostic performs the following:

1. `vendor_ID_test` – Verifies the PCIO ASIC vendor ID is 108e.
2. `device_ID_test` – Verifies the PCIO ASIC device ID is 1000.
3. `mixmode_read` – Verifies the PCI configuration space is accessible as half-word bytes by reading the EBus2 vendor ID address.
4. `e2_class_test` – Verifies the address class code. Address class codes include bridge device (0 x B, 0 x 6), other bridge device (0 x A and 0 x 80), and programmable interface (0 x 9 and 0 x 0).
5. `status_reg_walk1` – Performs walk-one test on status register with mask 0 x 280 (PCIO ASIC is accepting fast back-to-back transactions, DEVSEL timing is 0 x 1).
6. `line_size_walk1` – Performs tests a through e.
7. `latency_walk1` – Performs walk1 test on latency timer.
8. `line_walk1` – Performs walk1 test on interrupt line.
9. `pin_test` – Verifies interrupt pin is logic-level high (1) after reset.

CODE EXAMPLE 4-16 identifies the PCI/PCIO output message.

CODE EXAMPLE 4-16 PCI/PCIO Output Message

```
Enter (0-12 tests, 13 -Quit, 14 -Menu) ==> 0

TEST='all_pci/cheerio_test'
SUBTEST='vendor_id_test'
SUBTEST='device_id_test'
SUBTEST='mixmode_read'
SUBTEST='e2_class_test'
```

CODE EXAMPLE 4-16 PCI/PCIO Output Message (Continued)

```
SUBTEST='status_reg_walk1'  
SUBTEST='line_size_walk1'  
SUBTEST='latency_walk1'  
SUBTEST='line_walk1'  
SUBTEST='pin_test'  
Enter (0-12 tests, 13 -Quit, 14 -Menu) ===>
```

4.7.2 EBus DMA/TCR Registers

The EBus DMA/TCR registers diagnostic performs the following:

1. `DMA_reg_test` - Performs a walking ones bit test for control status register, address register, and byte count register of each channel. Verifies that the control status register is set properly.
2. `DMA_func_test` - Validates the DMA capabilities and FIFOs. Test is executed in a DMA diagnostic loopback mode. Initializes the data of transmitting memory with its address, performs a DMA read and write, and verifies that the data received is correct. Repeats for four channels.

CODE EXAMPLE 4-17 identifies the EBus DMA/TCR registers output message.

CODE EXAMPLE 4-17 EBus DMA/TCR Registers Output Message

```
Enter (0-12 tests, 13 -Quit, 14 -Menu) ==> 1  
  
TEST='all_dma/ebus_test'  
SUBTEST='dma_reg_test'  
SUBTEST='dma_func_test'  
Enter (0-12 tests, 13 -Quit, 14 -Menu) ==>
```

4.7.3 Ethernet

The Ethernet diagnostic performs the following:

1. `my_channel_reset` - Resets the Ethernet channel.
2. `hme_reg_test` - Performs Walk1 on the following registers set: global register 1, global register 2, bmac xif register, bmac tx register, and the mif register.

3. MAC-internal-loopback-test - Performs Ethernet channel engine internal loopback.
4. 10_mb_xcvr_loopback_test - Enables the 10BASE-T data present at the transmit MII data inputs to be routed back to the receive MII data outputs.
5. 100_mb_phy_loopback_test - Enables MII transmit data to be routed to the MII receive data path.
6. 100_mb_twister_loopback_test - Forces the twisted-pair transceiver into loopback mode.

CODE EXAMPLE 4-18 identifies the Ethernet output message.

CODE EXAMPLE 4-18 Ethernet Output Message

```
Enter (0-12 tests, 13 -Quit, 14 -Menu) ==> 2

TEST='ethernet_test'
SUBTEST='my_channel_reset'
SUBTEST='hme_reg_test'
SUBTEST='global_reg1_test'
SUBTEST='global_reg2_test'
SUBTEST='bmac_xif_reg_test'
SUBTEST='bmac_tx_reg_test'
SUBTEST='mif_reg_test'
SUBTEST='mac_internal_loopback_test'
SUBTEST='10mb_xcvr_loopback_test'
SUBTEST='100mb_phy_loopback_test'
SUBTEST='100mb_twister_loopback_test'
Enter (0-12 tests, 13 -Quit, 14 -Menu) ==>
```

4.7.4 Keyboard

The keyboard diagnostic consists of an external and an internal loopback. The external loopback requires a passive loopback connector. The internal loopback verifies the keyboard port by transmitting and receiving 128 characters.

CODE EXAMPLE 4-19 identifies the keyboard output message.

CODE EXAMPLE 4-19 Keyboard Output Message

```
Enter (0-12 tests, 13 -Quit, 14 -Menu) ====> 3

TEST='keyboard_test'
SUBTEST='internal_loopback'
Enter (0-12 tests, 13 -Quit, 14 -Menu) ====>
```

4.7.5 Mouse

The mouse diagnostic performs a keyboard-to-mouse loopback.

CODE EXAMPLE 4-20 identifies the mouse output message.

Note – For the `mouse_test` to pass, an external loopback connector is required.

CODE EXAMPLE 4-20 Mouse Output Message

```
Enter (0-12 tests, 13 -Quit, 14 -Menu) ====> 4

TEST='mouse_test'
SUBTEST='mouse_loopback'

###OBDIAG_MFG_START###
TEST='mouse_test'
STATUS='FAILED'
SUBTEST='mouse_loopback'
ERRORS='1 '
TTF='227 '
SPEED='295.99 MHz'
PASSES='1 '
MESSAGE='Error: Timeout receiving a character'
Enter (0-12 tests, 13 -Quit, 14 -Menu) ====>
```

4.7.6 Floppy

The floppy diagnostic verifies the diskette drive controller initialization. It also validates the status of a selected hard drive and reads the diskette drive header.

CODE EXAMPLE 4-21 identifies the floppy output message.

CODE EXAMPLE 4-21 Floppy Output Message

```
Enter (0-12 tests, 13 -Quit, 14 -Menu) ==> 5

TEST='floppy_test'
SUBTEST='floppy_id0_read_test'
Enter (0-12 tests, 13 -Quit, 14 -Menu) ==>
```

4.7.7 Parallel Port

The parallel port diagnostic performs the following:

1. `sio-passive-lb` - Sets up the SuperIO configuration register to enable extended/compatible parallel port select, then does a write 0, walk one, write 0 x ff to the data register. It verifies the results by reading the status register.
2. `dma_read` - Enables ECP mode and ECP DMA configuration, and FIFO test mode. Transfers 16 bytes of data from memory to the parallel port device and then verifies the data is in TFIFO.

CODE EXAMPLE 4-22 identifies the parallel port output message.

CODE EXAMPLE 4-22 Parallel Port Output Message

```
Enter (0-12 tests, 13 -Quit, 14 -Menu) ==> 6

TEST='parallel_port_test'
SUBTEST='dma_read'
Enter (0-12 tests, 13 -Quit, 14 -Menu) ==>
```

4.7.8 Serial Port A

The serial port A diagnostic invokes the `uart-loopback` test. The `uart-loopback` test transmits and receives 128 characters and checks the transaction validity.

CODE EXAMPLE 4-23 identifies the serial port A output message.

Note – The serial port A diagnostic will stall if the tip line is installed on serial port A.

CODE EXAMPLE 4-23 Serial Port A Output Message

```
Enter (0-12 tests, 13 -Quit, 14 -Menu) ==> 7

TEST='uarta_test'
BAUDRATE='1200'
BAUDRATE='1800'
BAUDRATE='2400'
BAUDRATE='4800'
BAUDRATE='9600'
BAUDRATE='19200'
BAUDRATE='38400'
BAUDRATE='57600'
BAUDRATE='76800'
BAUDRATE='115200'
BAUDRATE='153600'
BAUDRATE='230400'
BAUDRATE='307200'
BAUDRATE='460800'
Enter (0-12 tests, 13 -Quit, 14 -Menu) ==>
```

Note – The serial port A diagnostic will stall if the TIP line is installed on serial port A. CODE EXAMPLE 4-17 identifies the serial port A output message when the TIP line is installed on serial port A.

CODE EXAMPLE 4-24 Serial Port A Output Message with TIP Line Installed

```
Enter (0-12 tests, 13 -Quit, 14 -Menu) ==> 7

TEST='uarta_test'
'UART A in use as console - Test not run.'
Enter (0-12 tests, 13 -Quit, 14 -Menu) ==>
```

4.7.9 Serial Port B

The serial port B diagnostic is identical to the serial port A.

CODE EXAMPLE 4-25 identifies the serial port B output message.

Note – The serial port B diagnostic will stall if the tip line is installed on serial port B.

CODE EXAMPLE 4-25 Serial Port B Output Message

```
Enter (0-12 tests, 13 -Quit, 14 -Menu) ==> 8

TEST='uartb_test'
BAUDRATE='1200'
BAUDRATE='1800'
BAUDRATE='2400'
BAUDRATE='4800'
BAUDRATE='9600'
BAUDRATE='19200'
BAUDRATE='38400'
BAUDRATE='57600'
BAUDRATE='76800'
BAUDRATE='115200'
BAUDRATE='153600'
BAUDRATE='230400'
BAUDRATE='307200'
BAUDRATE='460800'
Enter (0-12 tests, 13 -Quit, 14 -Menu) ==>
```

4.7.10 NVRAM

The NVRAM diagnostic verifies the NVRAM operation by performing a write and read to the NVRAM.

CODE EXAMPLE 4-26 identifies the NVRAM output message.

CODE EXAMPLE 4-26 NVRAM Output Message

```
Enter (0-12 tests, 13 -Quit, 14 -Menu) ==> 9

TEST='nvrाम_test'
SUBTEST='write/read_patterns'
SUBTEST='write/read_inverted_patterns'
Enter (0-12 tests, 13 -Quit, 14 -Menu) ==>
```

4.7.11 Audio

The audio diagnostic performs the following:

1. cs4231_test – Verifies the cs4231 internal registers.
2. Line-in to line-out external loopback.
3. Microphone to headphone external loopback.

CODE EXAMPLE 4-27 identifies the audio output message.

CODE EXAMPLE 4-27 Audio Output Message

```
Enter (0-12 tests, 13 -Quit, 14 -Menu) ==> 10

TEST='audio_test'
SUBTEST='cs4231_test'
Fail on probing Audio module.
SUBTEST='external_lpbk'
External Audio Test not run: Please set the mfg-mode to sys-ext.
###OBDIAG_MFG_START###
TEST='audio_test'
STATUS='FAILED'
SUBTEST='external_lpbk'
ERRORS='1 '
TTF='439 '
SPEED='295.99 MHz'
PASSES='1 '
MESSAGE='Error: '
Enter (0-12 tests, 13 -Quit, 14 -Menu) ==>
```

4.7.12 SCSI

The SCSI diagnostic validates both the SCSI chip and the SCSI bus subsystem.

CODE EXAMPLE 4-28 identifies the SCSI output message.

CODE EXAMPLE 4-28 SCSI Output Message

```
Enter (0-12 tests, 13 -Quit, 14 -Menu) ==> 11
```

CODE EXAMPLE 4-28 SCSI Output Message (Continued)

```
TEST='selftest'  
Enter (0-12 tests, 13 -Quit, 14 -Menu) ===>
```

4.7.13 All Above

The all above diagnostic validates the system unit.

CODE EXAMPLE 4-29 identifies the all above output message.

Note – The all above diagnostic will stall if the `tip` line is installed on serial port A or serial port B.

CODE EXAMPLE 4-29 All Above Output Message

```
Enter (0-12 tests, 13 -Quit, 14 -Menu) ===> 12  
  
TEST='all_pci/cheerio_test'  
SUBTEST='vendor_id_test'  
SUBTEST='device_id_test'  
SUBTEST='mixmode_read'  
SUBTEST='e2_class_test'  
SUBTEST='status_reg_walk1'  
SUBTEST='line_size_walk1'  
SUBTEST='latency_walk1'  
SUBTEST='line_walk1'  
SUBTEST='pin_test'  
  
TEST='all_dma/ebus_test'  
SUBTEST='dma_reg_test'  
SUBTEST='dma_func_test'  
  
TEST='ethernet_test'  
SUBTEST='my_channel_reset'  
SUBTEST='hme_reg_test'  
SUBTEST='global_reg1_test'  
SUBTEST='global_reg2_test'  
SUBTEST='bmac_xif_reg_test'  
SUBTEST='bmac_tx_reg_test'  
SUBTEST='mif_reg_test'  
SUBTEST='mac_internal_loopback_test'
```

CODE EXAMPLE 4-29 All Above Output Message (Continued)

```
SUBTEST='10mb_xcvr_loopback_test'  
SUBTEST='100mb_phy_loopback_test'  
SUBTEST='100mb_twister_loopback_test'  
  
TEST='keyboard_test'  
SUBTEST='internal_loopback'  
  
TEST='mouse_test'  
SUBTEST='mouse_loopback'  
  
###OBDIAG_MFG_START###  
TEST='mouse_test'  
STATUS='FAILED'  
SUBTEST='mouse_loopback'  
ERRORS='1 '  
TTF='83 '  
SPEED='295.99 MHz'  
PASSES='1 '  
MESSAGE='Error: Timeout receiving a character'  
  
TEST='floppy_test'  
SUBTEST='floppy_id0_read_test'  
  
TEST='parallel_port_test'  
SUBTEST='dma_read'  
  
TEST='uarta_test'  
'UART A in use as console - Test not run.'  
  
TEST='uartb_test'  
BAUDRATE='1200'  
BAUDRATE='1800'  
BAUDRATE='2400'  
BAUDRATE='4800'  
BAUDRATE='9600'  
BAUDRATE='19200'  
BAUDRATE='38400'  
BAUDRATE='57600'  
BAUDRATE='76800'  
BAUDRATE='115200'  
BAUDRATE='153600'  
BAUDRATE='230400'  
BAUDRATE='307200'  
BAUDRATE='460800'  
  
TEST='nvram_test'
```

CODE EXAMPLE 4-29 All Above Output Message (Continued)

```
SUBTEST='write/read_patterns'  
SUBTEST='write/read_inverted_patterns'  
  
TEST='audio_test'  
SUBTEST='cs4231_test'  
Fail on probing Audio module.  
SUBTEST='external_lpbk'  
External Audio Test not run: Please set the mfg-mode to sys-ext.  
###OBDIAG_MFG_START###  
TEST='audio_test'  
STATUS='FAILED'  
SUBTEST='external_lpbk'  
ERRORS='1 '  
TTF='97 '  
SPEED='295.99 MHz'  
PASSES='1 '  
MESSAGE='Error: internal_loopback TBD'  
  
TEST='selftest'  
Enter (0-12 tests, 13 -Quit, 14 -Menu) ===>0
```

▼ To recover the original N1fsVRAM variable settings:

1. At the `ok` prompt, type:

CODE EXAMPLE 4-30

```
ok setenv mfg-mode off  
  
mfg-mode = off
```

2. At the `ok` prompt, type:

CODE EXAMPLE 4-31

```
ok setenv diag-switch? false  
  
diag-switch? = false
```

3. At the `ok` prompt, type:

CODE EXAMPLE 4-32

```
ok setenv auto-boot? true  
auto-boot? = true
```

4. At the ok prompt, type:

CODE EXAMPLE 4-33

```
ok reset-all
```

Safety and Tool Requirements

This chapter describes the safety requirements, symbols, safety precautions, and tools required.

This chapter contains the following topics:

- Section 5.1 “Safety Requirements” on page 5-1
- Section 5.2 “Symbols” on page 5-1
- Section 5.3 “Safety Precautions” on page 5-2
- Section 5.4 “Tools Required” on page 5-3

5.1 Safety Requirements

For protection, observe the following safety precautions when setting up the equipment:

- Follow all cautions, warnings, and instructions marked on the equipment.
- Ensure that the voltages and frequency rating of the power receptacle match the electrical rating label on the equipment.
- Never push objects of any kind through openings in the equipment. They may touch dangerous voltage points or short components resulting in fire or electric shock.
- Refer servicing of equipment to qualified personnel.

5.2 Symbols

The following symbols mean:



Caution – Risk of personal injury and equipment damage. Follow the instructions.



Caution – Hazardous voltages are present. To reduce the risk of electric shock and danger to personal health, follow the instructions.



Caution – Hot surfaces. Avoid contact. Surfaces are hot and may cause personal injury if touched.

5.3 Safety Precautions

Follow all safety precautions.

5.3.1 Modification to Equipment



Caution – Do not make mechanical or electrical modifications to the equipment. Sun Microsystems is not responsible for regulatory compliance of a modified Sun product.

5.3.2 Placement of a Sun Product



Caution – To ensure reliable operation of the Sun product and to protect it from overheating, openings in the equipment must not be blocked or covered. A Sun product should never be placed near a radiator or hot air register.

5.3.3 Power Cord Connection



Caution – Not all power cords have the same current ratings. Household extension cords do not have overload protection. Do not use household extension cords with the Sun product.



Caution – The power switch of this product functions as a standby type device only. The power cord serves as the primary disconnect device for the system. Be sure to connect the power cord into a grounded electrical receptacle that is nearby the system and is readily accessible. Do not connect the power cord when the power supply has been removed from the system chassis.

5.3.4 Electrostatic Discharge



Caution – The boards and hard disk drives contain electronic components that are extremely sensitive to static electricity. Ordinary amounts of static electricity from clothes or the work environment can destroy components.

Do not touch the components themselves or any metal parts. Wear a wrist strap when handling the drive assemblies, boards or the cards.

5.3.5 Lithium Battery



Caution – On Sun system boards, a lithium battery is molded into the real-time clock, SDS No. M48T59Y, MK48TXXB-XX, M48T18-XXXPCZ or M48T59W-XXXPCZ. Batteries are not customer-replaceable parts. They may explode if mistreated. Do not dispose of the battery in fire. Do not disassemble it or attempt to recharge it.

5.4 Tools Required

The following tools are required to service the Ultra 30 computer (system unit).

- No. 2 Phillips screwdriver (magnetized tip suggested)

- Needle-nose pliers
- Grounding wrist strap
- Digital voltage meter (DVM)
- Antistatic mat

Place ESD-sensitive components such as system board, circuit cards, disk drives, and TOD/NVRAM on an antistatic mat. The following items can be used as an antistatic mat:

- Bag used to wrap a Sun replacement part
- Shipping container used to package a Sun replacement part
- Inner side (metal part) of the system unit cover
- Sun ESD mat, part number 250-1088 (can be purchased through your Sun sales representative)
- Disposable ESD mat; shipped with replacement parts or optional system features

Power On and Off

This chapter contains procedures to power on and power off the Ultra 30 computer.

This chapter contains the following topics:

- Section 6.1 “Powering On the System Unit” on page 6-1
- Section 6.2 “Powering Off the System Unit” on page 6-3

Note – The actions required to power on and power off the system unit are also illustrated with photographs and audio/visual instructions on the *Sun Ultra 30 ShowMe How Multimedia Documentation*, part number 704-5681.

6.1 Powering On the System Unit

To power on the system unit:

1. **Turn on power to all connected peripherals.**

Note – Peripheral power is activated prior to system power so the system can recognize the peripherals when it is activated.

2. **Connect the AC power cord.**
3. **Set the front panel power switch to the On position (FIGURE 6-1) or press the Sun Type-5 keyboard Power-on key (FIGURE 6-2).**
4. **Verify the following:**
 - a. **The front panel LED is on.**

b. The system unit fans are spinning.

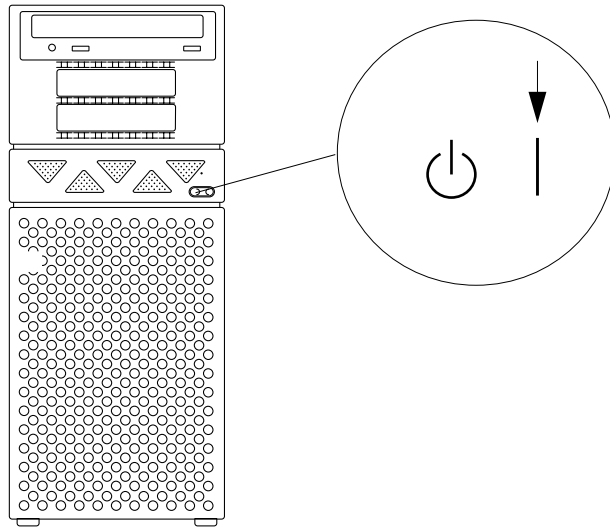

FIGURE 6-1 System Power On (Front Panel)

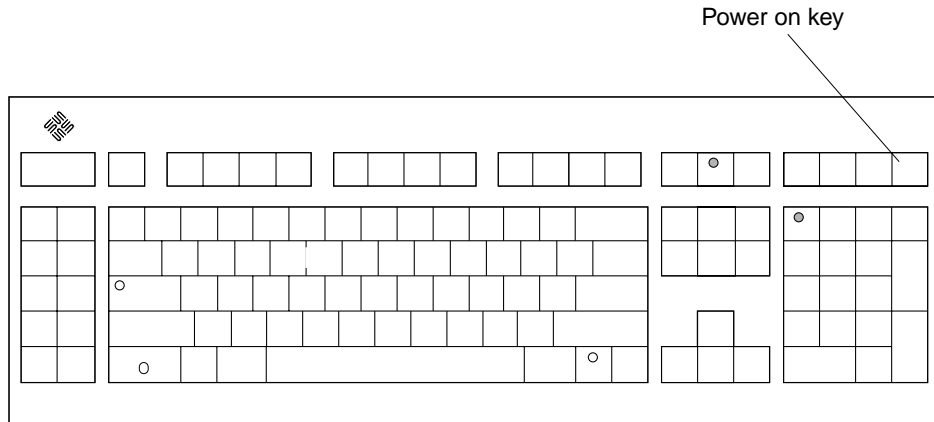

FIGURE 6-2 Sun Type-5 Keyboard

6.2 Powering Off the System Unit



Caution – Prior to turning off system power, exit from the operating system. Failure to do so may result in data loss.



Caution – Wear an antistatic wrist strap and use an ESD-protected mat when handling components. When servicing or removing system unit components, attach an ESD strap to your wrist, then to a metal area on the chassis, and then disconnect the power cord from the system unit and the wall receptacle. Following this caution equalizes all electrical potentials with the system unit.

To power off the system unit:

1. Back up system files and data.

See *Solaris Handbook for SMCC Peripherals*, part number 802-7675.

2. Halt the system.



Caution – Pressing the front panel power switch does not remove all power from the system unit; a trickle voltage remains in the power supply. To remove all power from the system unit, disconnect the AC power cord from the system unit.

3. Set the front panel power switch to the Off position (FIGURE 6-3).



Caution – Disconnect the AC power cord from the AC receptacle prior to servicing system components.

4. Verify the following:

a. The front panel LED is off.

b. The system unit fans are not spinning.



Caution – When the Power-on/Standby switch is in standby and the AC power cord remains connected to a power receptacle, AC voltage is present in the power supply primary.

5. Turn off the power to the monitor and any peripheral equipment.

6. Disconnect cables to any peripheral equipment.

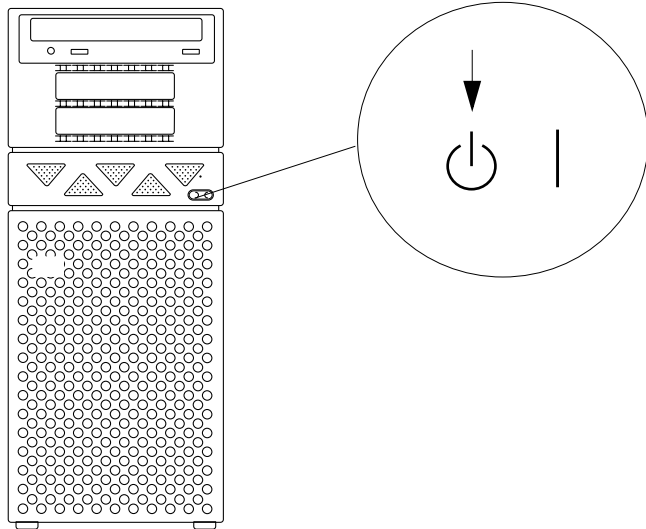

FIGURE 6-3 System Power Off (Front Panel)

Internal Access

This chapter describes how to access the Ultra 30 computer for service.

This chapter contains the following topics:

- Section 7.1 “Removing the Side Access Cover” on page 7-1
- Section 7.2 “Attaching the Wrist Strap” on page 7-4
- Section 7.3 “Replacing the Side Access Cover” on page 7-5

Note – How to access the Ultra 30 computer for service is also illustrated with photographs and audio/visual instructions on the *Sun Ultra 30 ShowMe How Multimedia Documentation*, part number 704-5681.

7.1 Removing the Side Access Cover

1. Power off the system unit.

See Section 6.2 “Powering Off the System Unit” on page 6-3

2. Disconnect the lock block (FIGURE 7-1).

3. Lay the system unit in the service position.

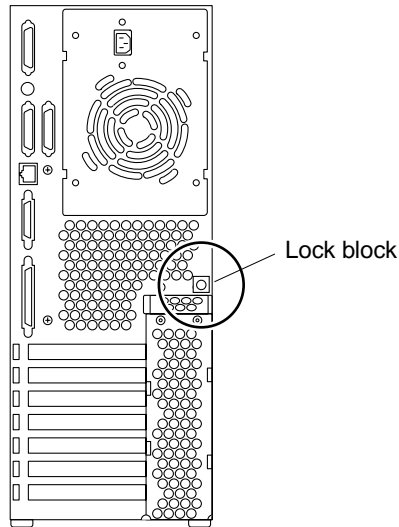

FIGURE 7-1 Lock Block Location

- 4. Remove the side access cover as follows (FIGURE 7-2):**
 - a. Grasp the side panel and pull it toward the back of the system unit.**
 - b. Disengage the side access cover from the chassis hooks.**
 - c. Grasping the access cover sides, lift the side access cover up and remove.**

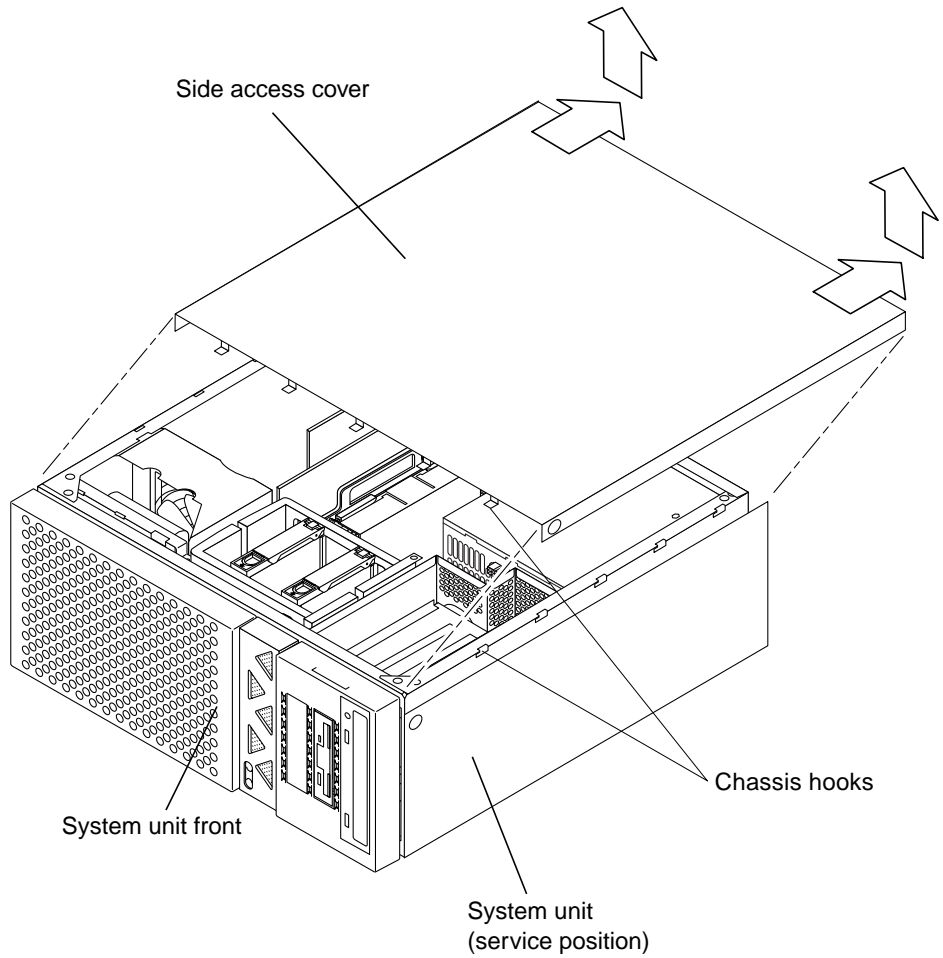

FIGURE 7-2 Removing the Side Access Cover

7.2

Attaching the Wrist Strap



Caution – Wear an antistatic wrist strap and use an ESD-protected mat when handling components. When servicing or removing system unit components, an ESD strap should be attached to the wrist, then to a metal area on the chassis, and then the power cord should be removed from the system unit and the wall receptacle. Following this caution equalizes all electrical potentials within the system unit.

1. **Unwrap the first two folds of the wrist strap; wrap the adhesive side firmly against the wrist.**
2. **Peel the liner from the copper foil at the opposite end of the wrist strap.**
3. **Attach the copper end of the wrist strap to the chassis (FIGURE 7-3).**
4. **Disconnect the AC power cord.**

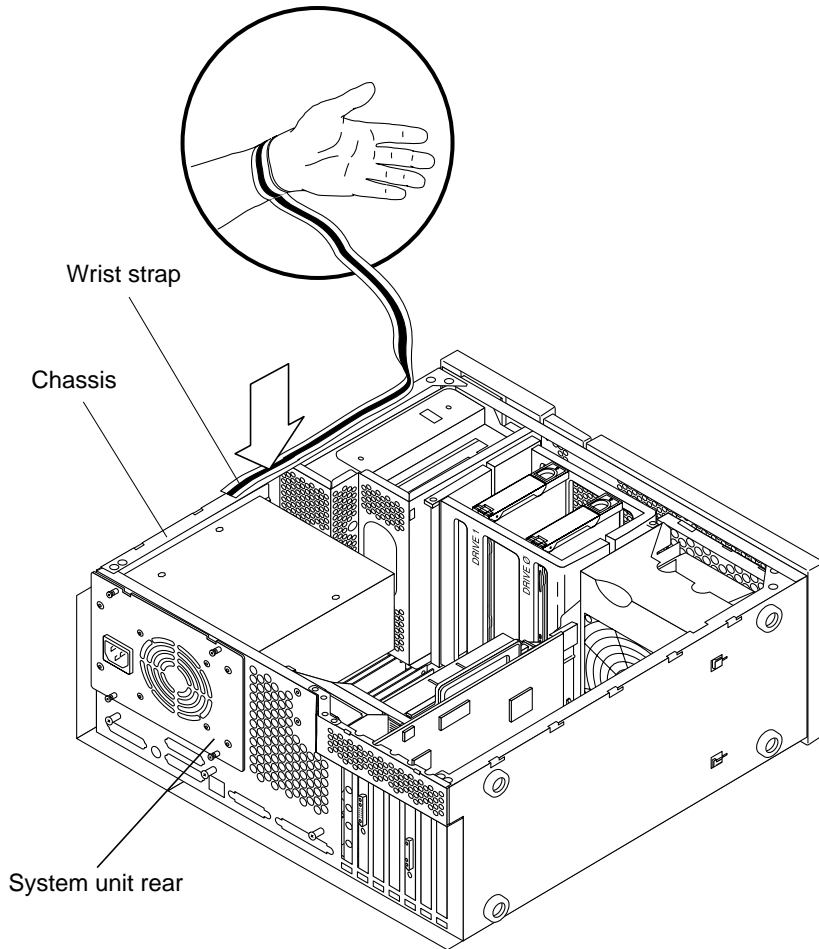

FIGURE 7-3 Attaching the Wrist Strap

7.3 Replacing the Side Access Cover

1. **Position the side access cover (FIGURE 7-4).**
2. **Engage the side access cover and the chassis hooks. Push the access cover toward the system unit front.**
3. **Connect the lock block (FIGURE 7-1).**

4. Position the system unit in the operating position.

5. Power on the system unit.

See Section 6.1 "Powering On the System Unit" on page 6-1

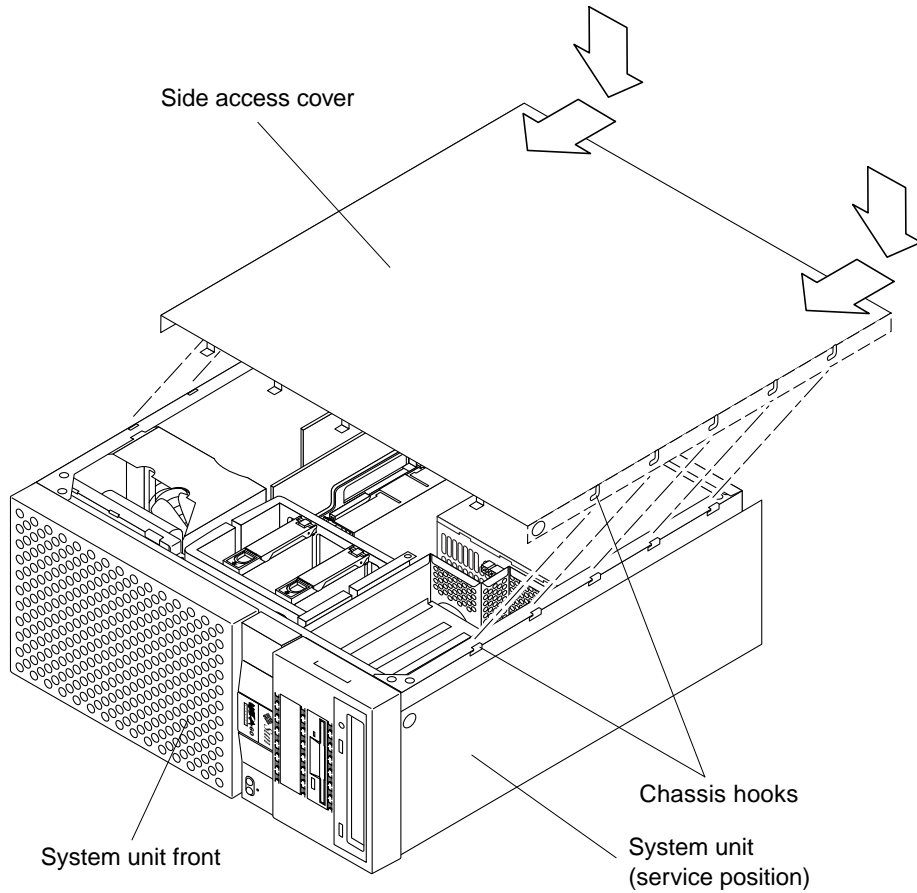

FIGURE 7-4 Replacing the Side Access Cover

Major Subassemblies

This chapter describes how to remove and replace the major subassemblies.

This chapter contains the following topics:

- Section 8.1 “Power Supply” on page 8-1
- Section 8.2 “PCI Fan Assembly” on page 8-5
- Section 8.3 “Hard Drive Bay With SCSI Assembly” on page 8-7
- Section 8.4 “Cable Assemblies” on page 8-10
- Section 8.5 “EMI Filler Panels” on page 8-16
- Section 8.6 “Chassis Foot” on page 8-18
- Section 8.7 “Speaker Assembly” on page 8-20
- Section 8.8 “DC Switch Assembly” on page 8-22
- Section 8.9.1 “One-Piece Shroud Assembly” on page 8-25
- Section 8.9.2 “Two-Piece Shroud Assembly” on page 8-28
- Section 8.9.3 “Two-Piece Shroud Fan Assembly” on page 8-30

Note – Removal and replacement of major subassemblies are also illustrated with photographs and audio/visual instructions on the *Sun Ultra 30 ShowMe How Multimedia Documentation*, part number 704-5681.

8.1 Power Supply

To remove and replace the power supply, proceed as follows.

8.1.1 Removing the Power Supply

1. Power off the system unit.

See Section 6.2 “Powering Off the System Unit” on page 6-3.

2. Remove the side access cover.

See Section 7.1 “Removing the Side Access Cover” on page 7-1.



Caution – Use proper ESD grounding techniques when handling components. Wear an antistatic wrist strap and use an ESD-protected mat. Store ESD-sensitive components in antistatic bags before placing them on any surface.



Caution – When removing the power supply, attach the copper end of the wrist strap to the system unit chassis, not the power supply.

3. Attach the wrist strap.

See Section 7.2 “Attaching the Wrist Strap” on page 7-4.

4. Remove the power supply as follows (FIGURE 8-1 and FIGURE 8-2):

- a. Using a number 2 Phillips screwdriver, loosen the four captive screws securing the power supply to the chassis.
- b. Slide the power supply from the chassis rear until the power supply is stopped by the power supply cables.
- c. Disconnect the peripheral cable connector from the power supply.
- d. Disconnect the power supply cables from the motherboard (not illustrated).
- e. Remove the power supply from the chassis.

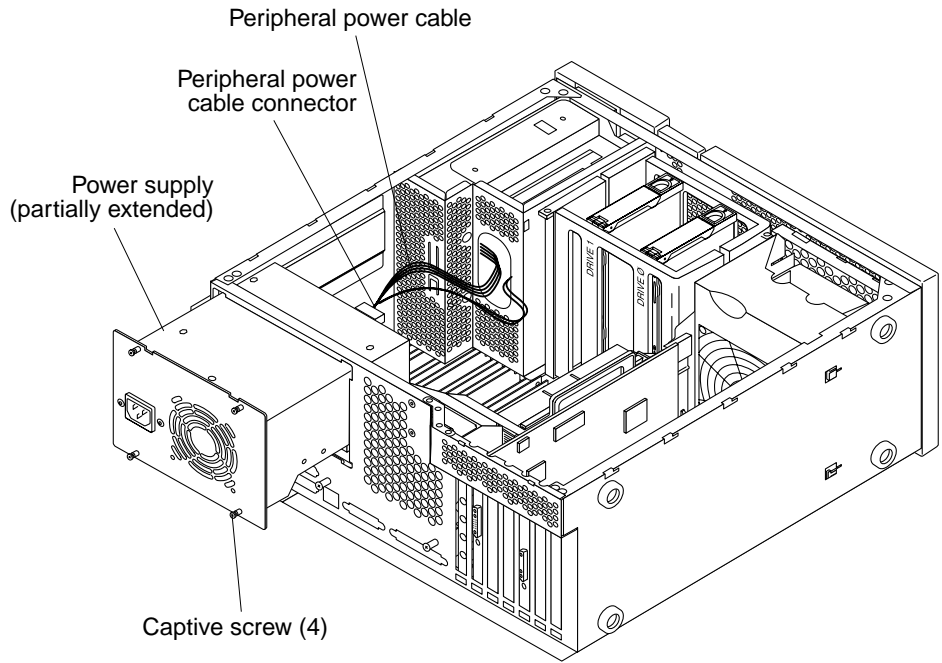

FIGURE 8-1 Removing and Replacing the Power Supply (Part 1 of 2)

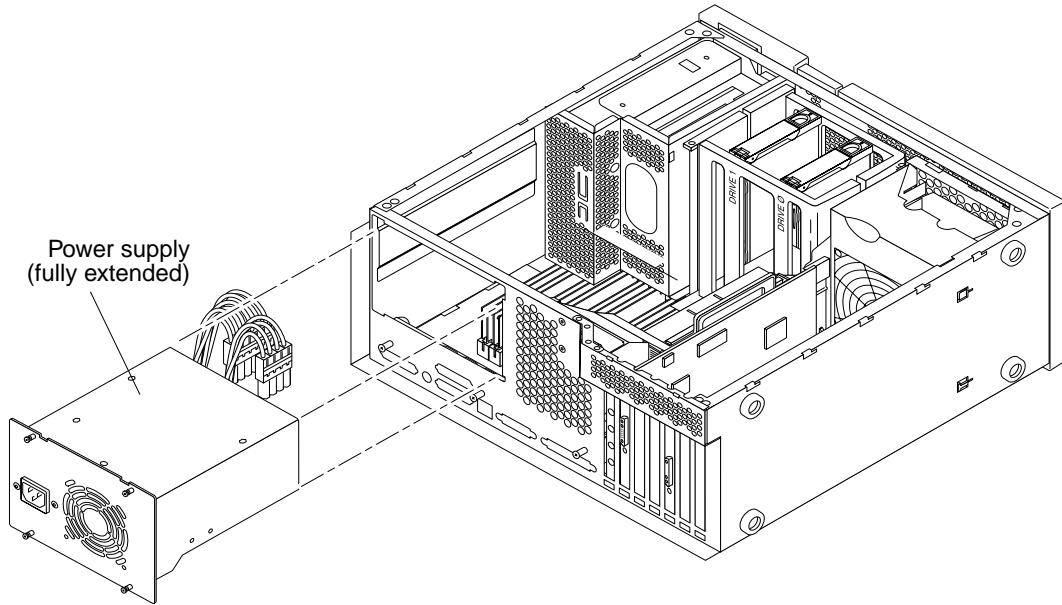

FIGURE 8-2 Removing and Replacing the Power Supply (Part 2 of 2)

8.1.2 Replacing the Power Supply



Caution – Use proper ESD grounding techniques when handling components. Wear an antistatic wrist strap and use an ESD-protected mat. Store ESD-sensitive components in antistatic bags before placing them on any surface.

1. **Replace the power supply as follows (FIGURE 8-1 and FIGURE 8-2):**
 - a. **Feed the power supply cables through the chassis opening; support the power supply cables while engaging the power supply into the chassis rails.**
 - b. **Position the power supply into the chassis.**
 - c. **Slide the power supply toward the chassis front.**
 - d. **Connect the power cables to the motherboard.**
 - e. **Connect the peripheral cable connector to the power supply.**
 - f. **Replace the peripheral power cable through the cable routing clips.**

- g. Slide the power supply toward the chassis front until the power supply rear panel is flush with the chassis.
- h. Using a number 2 Phillips screwdriver, tighten the captive screws securing the power supply to the chassis.

Note – Tighten the captive screws in a clockwise order beginning with the upper right captive screw.

2. **Connect the AC power cord.**
3. **Detach the wrist strap.**
4. **Replace the side access cover.**
See Section 7.3 “Replacing the Side Access Cover” on page 7-5.
5. **Power on the system unit.**
See Section 6.1 “Powering On the System Unit” on page 6-1.

8.2 PCI Fan Assembly

To remove and replace the PCI fan assembly, proceed as follows.

8.2.1 Removing the PCI Fan Assembly

1. **Power off the system.**
See Section 6.2 “Powering Off the System Unit” on page 6-3.
2. **Remove the side access cover.**
See Section 7.1 “Removing the Side Access Cover” on page 7-1.



Caution – Use proper ESD grounding techniques when handling components. Wear an antistatic wrist strap and use an ESD-protected mat. Store ESD-sensitive components in antistatic bags before placing them on any surface.

3. **Attach the wrist strap.**
See Section 7.2 “Attaching the Wrist Strap” on page 7-4.
4. **Disconnect the PCI fan assembly as follows (FIGURE 8-3):**

- a. **Remove any long PCI cards.**
See Section 10.3.1 “Removing a PCI Card” on page 10-6.
 - b. **Remove any long UPA graphics cards.**
See Section 10.4.1 “Removing a UPA Graphics Card” on page 10-9.
 - c. **Disconnect the PCI fan power harness from the motherboard.**
 - d. **Press the locking snap and disengage.**
 - e. **Disengage the studs from the chassis slots.**
5. **Remove the PCI fan assembly by moving it back, over, and up.**

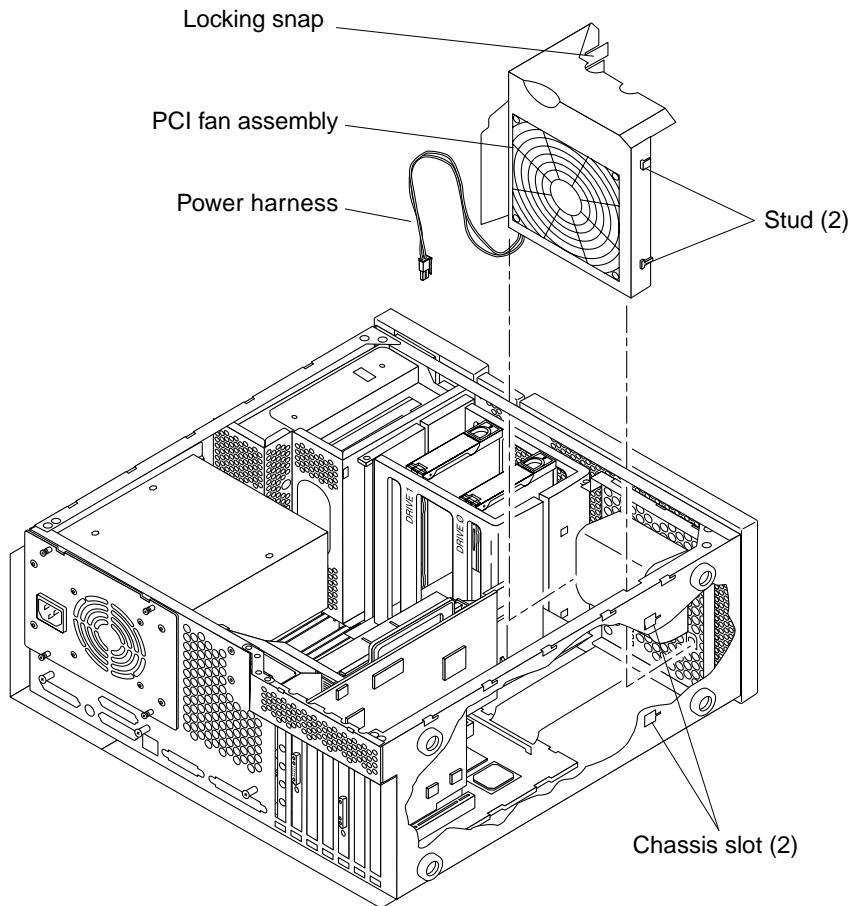

FIGURE 8-3 Removing and Replacing the PCI Fan Assembly

8.2.2 Replacing the PCI Fan Assembly



Caution – Use proper ESD grounding techniques when handling components. Wear an antistatic wrist strap and use an ESD-protected mat. Store ESD-sensitive components in antistatic bags before placing them on any surface.

1. **Position the PCI fan over the speaker assembly** (FIGURE 8-3).
2. **Connect the PCI fan as follows** (FIGURE 8-3):
 - a. **Position the studs into the chassis slots and engage.**
 - b. **Press the locking snap and engage.**
 - c. **Connect the power harness to the motherboard.**
 - d. **Replace any long UPA graphics cards.**
See Section 10.4.2 “Replacing a UPA Graphics Card” on page 10-11.
 - e. **Replace any long PCI cards.**
See Section 10.3.2 “Replacing a PCI Card” on page 10-8.
3. **Connect the AC power cord.**
4. **Detach the wrist strap.**
5. **Replace the side access cover.**
See Section 7.3 “Replacing the Side Access Cover” on page 7-5.
6. **Power on the system unit.**
See Section 6.1 “Powering On the System Unit” on page 6-1.

8.3 Hard Drive Bay With SCSI Assembly

To remove and replace the hard drive bay with SCSI assembly (SCSI drive bay), proceed as follows.

8.3.1 Removing the SCSI Drive Bay

1. **Power off the system unit.**
See Section 6.2 “Powering Off the System Unit” on page 6-3.

2. Remove the side access cover.

See Section 7.1 “Removing the Side Access Cover” on page 7-1.



Caution – Use proper ESD grounding techniques when handling components. Wear an antistatic wrist strap and use an ESD-protected mat. Store ESD-sensitive components in antistatic bags before placing them on any surface.

3. Attach the wrist strap.

See Section 7.2 “Attaching the Wrist Strap” on page 7-4.

4. Remove the SCSI drive bay as follows (FIGURE 8-4):

a. Remove the hard drive(s).

See Section 9.1.1 “Removing a Hard Drive” on page 9-1.

b. Disconnect the SCSI cables from the motherboard connectors.

c. Disconnect the peripheral power cable.

d. Remove the peripheral power cable from the cable routing clips.

e. Remove the diskette drive cable from the plastic spring clips installed adjacent to the drive bay.

f. Unfeed the peripheral power cable through the chassis opening.

g. Using a number 2 Phillips screwdriver, remove the screws securing the SCSI drive bay to the chassis.

h. Feed the SCSI cable under the PCI fan bracket while pulling up in Step 4-g.

i. Slide the SCSI drive bay out of the chassis.

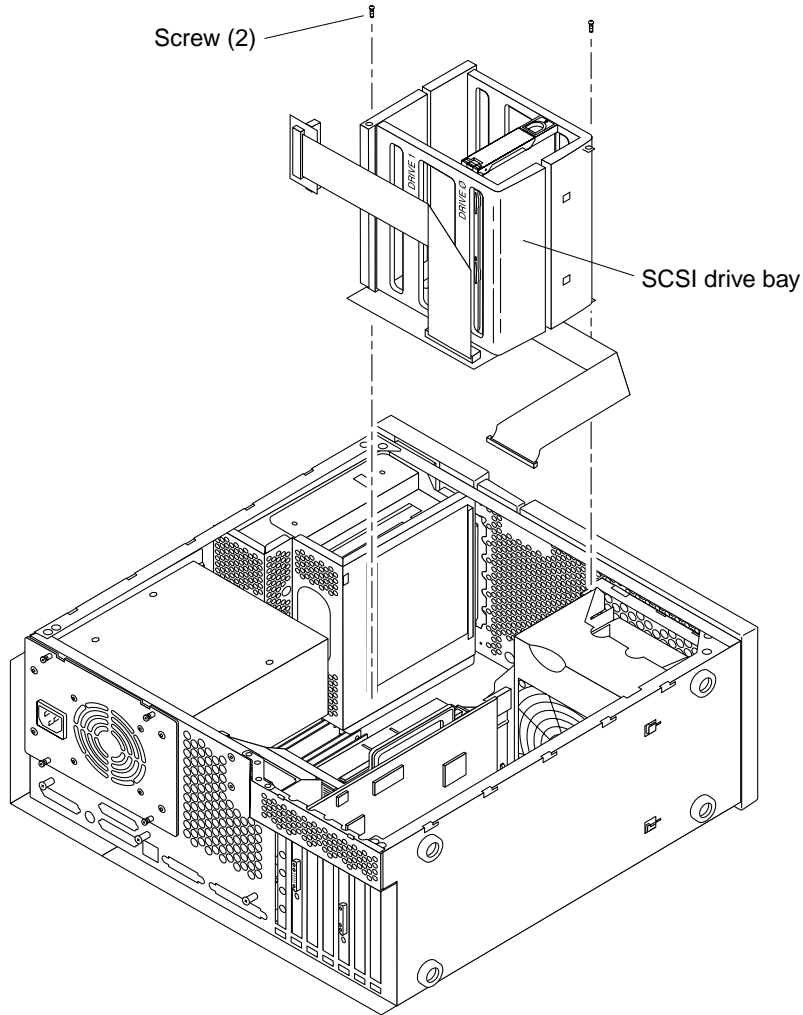

FIGURE 8-4 Removing and Replacing the SCSI Drive Bay

8.3.2 Replacing the SCSI Drive Bay



Caution – Use proper ESD grounding techniques when handling components. Wear an antistatic wrist strap and use an ESD-protected mat. Store ESD-sensitive components in antistatic bags before placing them on any surface.

1. **Replace the SCSI drive bay as follows (FIGURE 8-4):**
 - a. **Position the SCSI drive bay on the channel slides and slide it in.**
 - b. **Using a number 2 Phillips screwdriver, replace the screws securing the SCSI drive bay to the chassis.**
 - c. **Connect the SCSI cables to the motherboard connectors.**
 - d. **Press the SCSI cables into the cage hole and beneath the PCI fan assembly.**
 - e. **Replace the peripheral power cable into the cable routing clips.**
 - f. **Replace the diskette drive cable into the plastic spring clips installed adjacent to the drive bay.**
 - g. **Replace the hard drive(s).**

See Section 9.1.2 “Replacing a Hard Drive” on page 9-3.

Note – Hooks at the chassis base must lock into the bottom holes of the drive bracket.

2. **Connect the AC power cord.**
3. **Detach the wrist strap.**
4. **Replace the side access cover.**

See Section 7.3 “Replacing the Side Access Cover” on page 7-5.
5. **Power on the system unit.**

See Section 6.1 “Powering On the System Unit” on page 6-1.

8.4 Cable Assemblies

To remove and replace the peripheral power cable assembly, the diskette drive cable assembly, or the M6-type UPA graphics card cable assembly, proceed as follows.

8.4.1 Removing the Peripheral Power Cable Assembly

1. **Power off the system unit.**

See Section 6.2 “Powering Off the System Unit” on page 6-3.

2. Remove the side access cover.

See Section 7.1 “Removing the Side Access Cover” on page 7-1.



Caution – Use proper ESD grounding techniques when handling components. Wear an antistatic wrist strap and use an ESD-protected mat. Store ESD-sensitive components in antistatic bags before placing them on any surface.

3. Attach the wrist strap.

See Section 7.2 “Attaching the Wrist Strap” on page 7-4.

4. Disconnect the peripheral power cable assembly as follows:

a. Remove the peripheral power cable connector from the power supply.

b. Partially remove the drive tray.

See Section 9.2.1 “Removing the RMA” on page 9-4.

c. Remove the peripheral power cable connector from the CD-ROM drive (or tape drive) and the diskette drive.

d. Remove the peripheral power cable connector from the hard drive SCSI subassembly.

5. Remove the peripheral power cable from the cable routing clips.

6. Remove the peripheral power cable assembly.

8.4.2 Replacing the Peripheral Power Cable Assembly



Caution – Use proper ESD grounding techniques when handling components. Wear an antistatic wrist strap and use an ESD-protected mat. Store ESD-sensitive components in antistatic bags before placing them on any surface.

1. Position the peripheral power cable assembly into the chassis.

2. Replace the peripheral power cable through the cable routing clips.

3. Connect the following:

a. Replace the peripheral power cable connector to the hard drive SCSI subassembly.

b. Replace the peripheral power cable connector to the CD-ROM drive (or tape drive) and the diskette drive.

c. Replace the drive tray.

See Section 9.2.6 “Replacing the RMA” on page 9-8.

d. Replace the peripheral power cable connector to the power supply.

4. Connect the AC power cord.

5. Detach the wrist strap.

6. Replace the side access cover.

See Section 7.3 “Replacing the Side Access Cover” on page 7-5.

7. Power on the system unit.

See Section 6.1 “Powering On the System Unit” on page 6-1.

8.4.3 Removing the Diskette Drive Cable Assembly

1. Power off the system unit.

See Section 6.2 “Powering Off the System Unit” on page 6-3.

2. Remove the side access cover.

See Section 7.1 “Removing the Side Access Cover” on page 7-1.



Caution – Use proper ESD grounding techniques when handling components. Wear an antistatic wrist strap and use an ESD-protected mat. Store ESD-sensitive components in antistatic bags before placing them on any surface.

3. Attach the wrist strap.

See Section 7.2 “Attaching the Wrist Strap” on page 7-4.

4. Disconnect the diskette drive cable assembly as follows:

a. Partially remove the drive tray.

See Section 9.2.1 “Removing the RMA” on page 9-4.

b. Disconnect the SCSI cable from the CD-ROM drive (or tape drive) and unfeed the cable through the chassis opening to expose the diskette drive cable (underneath).

c. Remove the diskette drive cable connector from the diskette drive.

d. Remove the diskette drive cable from the plastic spring clips installed adjacent to the drive bay.

e. Remove the diskette drive cable connector from the motherboard.

5. Remove the diskette drive cable assembly.

8.4.4 Replacing the Diskette Drive Cable Assembly



Caution – Use proper ESD grounding techniques when handling components. Wear an antistatic wrist strap and use an ESD-protected mat. Store ESD-sensitive components in antistatic bags before placing them on any surface.

1. Position the diskette drive cable assembly into the chassis.
2. Connect the following:
 - a. Replace the diskette drive cable connector to the motherboard.
 - b. Replace the diskette drive cable into the plastic spring clips installed adjacent to the drive bay.
 - c. Replace the diskette drive cable connector to the diskette drive.
 - d. Connect the SCSI cable to the CD-ROM drive (or tape drive).
 - e. Replace the drive tray.

See Section 9.2.6 “Replacing the RMA” on page 9-8.
3. Connect the AC power cord.
4. Detach the wrist strap.
5. Replace the side access cover.

See Section 7.3 “Replacing the Side Access Cover” on page 7-5.
6. Power on the system unit.

See Section 6.1 “Powering On the System Unit” on page 6-1.

8.4.5 Removing the UPA Graphics Card Cable Assembly

1. Power off the system unit.

See Section 6.2 “Powering Off the System Unit” on page 6-3.
2. Disconnect the video cable from the graphics card video connector.

3. Remove the side access cover.

See Section 7.1 “Removing the Side Access Cover” on page 7-1.



Caution – Use proper ESD grounding techniques when handling components. Wear an antistatic wrist strap and use an ESD-protected mat. Store ESD-sensitive components in antistatic bags before placing them on any surface.

4. Attach the wrist strap.

See Section 7.2 “Attaching the Wrist Strap” on page 7-4.

5. Remove the UPA graphics card cable assembly as follows (FIGURE 8-5):

- a. Disconnect the two 10-position sockets from the mating connectors.
- b. Using a number 2 Phillips screwdriver, remove the screw securing the end panel to the chassis.
- c. Remove the UPA graphics card cable assembly end panel from the chassis PCI slot.

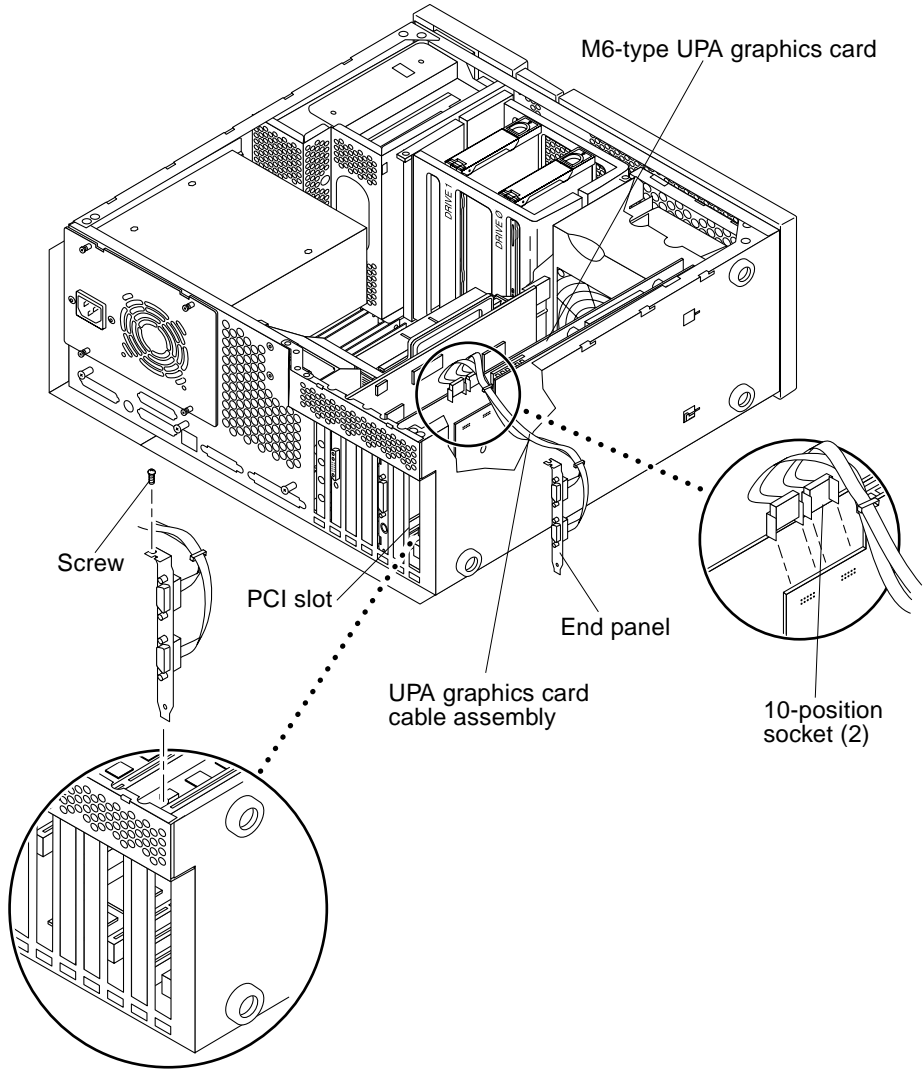

FIGURE 8-5 Removing and Replacing the UPA Graphics Card Cable Assembly

8.4.6 Replacing the UPA Graphics Card Cable Assembly

Note – The UPA graphics card cable assembly is installed only on an M6-type UPA graphics card.

1. **Replace the UPA graphics card cable assembly as follows (FIGURE 8-5):**
 - a. **Insert the cable assembly end panel into the chassis PCI slot.**
 - b. **Using a number 2 Phillips screwdriver, replace the screw securing the end panel to the chassis (not illustrated).**
 - c. **Connect the two 10-position sockets to the mating connectors.**

Note – One cable is shorter than the other to provide intuitive insertion. Sockets are polarized and marked.

- d. **Dress the cables away from the adjacent PCI slot.**
2. **Connect the AC power cord to the system unit.**
3. **Detach the wrist strap.**
4. **Replace the side access cover.**

See Section 7.3 “Replacing the Side Access Cover” on page 7-5.
5. **Connect the video cable to the graphics card video connector.**
6. **Power on the system unit.**

See Section 6.1 “Powering On the System Unit” on page 6-1.

8.5 EMI Filler Panels

To remove and replace the EMI filler panels from the front bezel or the drive tray, proceed as follows.

8.5.1 Removing an EMI Filler Panel

1. Identify the EMI filler panel to be removed.
2. Remove an EMI filler panel as follows (FIGURE 8-6):
 - a. Remove the front bezel.
 - b. Use your finger to pop the EMI filler panel from the bezel.
3. Remove the drive tray drive.
See Section 9.2.1 “Removing the RMA” on page 9-4.
4. Use your fingers to pop the drive tray EMI filler panel from the drive tray (FIGURE 8-7).

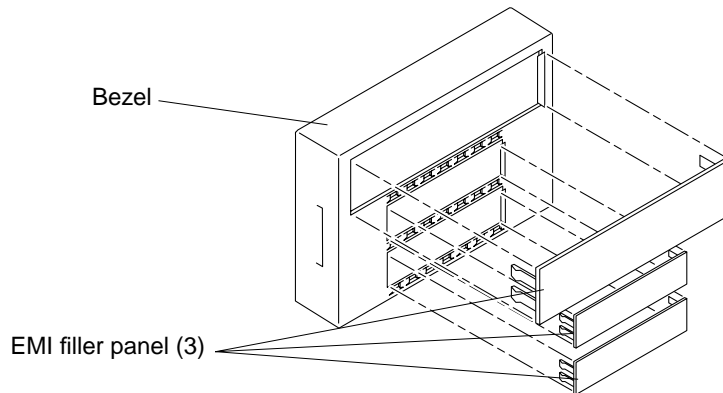

FIGURE 8-6 Removing and Replacing the Bezel EMI Filler Panel

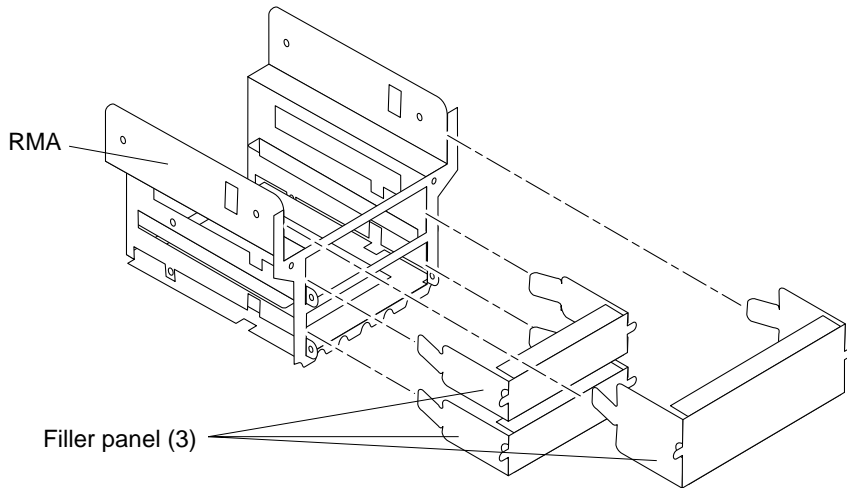

FIGURE 8-7 Removing and Replacing the RMA EMI Filler Panel

8.5.2 Replacing an EMI Filler Panel

1. **Position and snap the EMI filler panel into the RMA** (FIGURE 8-7).
2. **Replace the RMA.**
See Section 9.2.6 “Replacing the RMA” on page 9-8.
3. **Position and snap the EMI filler panel into the bezel** (FIGURE 8-6).

8.6 Chassis Foot

To remove and replace a chassis foot, proceed as follows.

8.6.1 Removing the Chassis Foot

1. **Power off the system unit.**
See Section 6.2 “Powering Off the System Unit” on page 6-3.
2. **Lay the system in the service position.**

3. Using a number 2 Phillips screwdriver, loosen the screw securing the chassis foot to the chassis (FIGURE 8-8).
4. Remove the chassis foot.

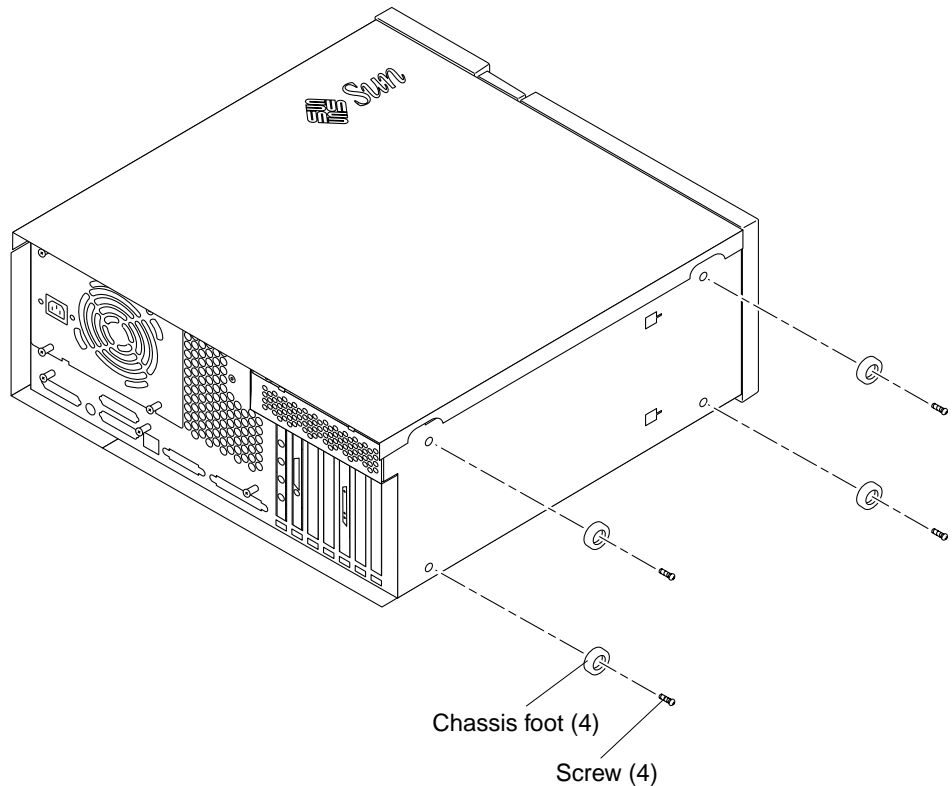

FIGURE 8-8 Removing and Replacing the Chassis Foot

8.6.2 Replacing the Chassis Foot

1. Position the chassis foot (FIGURE 8-8).
2. Using a number 2 Phillips screwdriver, tighten the screw securing the chassis foot to the chassis.
3. Position the system unit in the operating position.
4. Power on the system unit.
See Section 6.1 “Powering On the System Unit” on page 6-1.

8.7 Speaker Assembly

To remove and replace the speaker assembly, proceed as follows.

8.7.1 Removing the Speaker Assembly

1. Power off the system unit.

See Section 6.2 “Powering Off the System Unit” on page 6-3.

2. Remove the side access cover.

See Section 7.1 “Removing the Side Access Cover” on page 7-1.



Caution – Use proper ESD grounding techniques when handling components. Wear an antistatic wrist strap and use an ESD-protected mat. Store ESD-sensitive components in antistatic bags before placing them on any surface.

3. Attach the wrist strap.

See Section 7.2 “Attaching the Wrist Strap” on page 7-4.

4. Remove the PCI fan assembly.

See Section 8.2.1 “Removing the PCI Fan Assembly” on page 8-5.

5. Disconnect the speaker power cable from the motherboard (FIGURE 8-9).

6. Using a number 2 Phillips screwdriver, remove the screw securing the speaker assembly to the chassis.

7. Remove the speaker assembly.

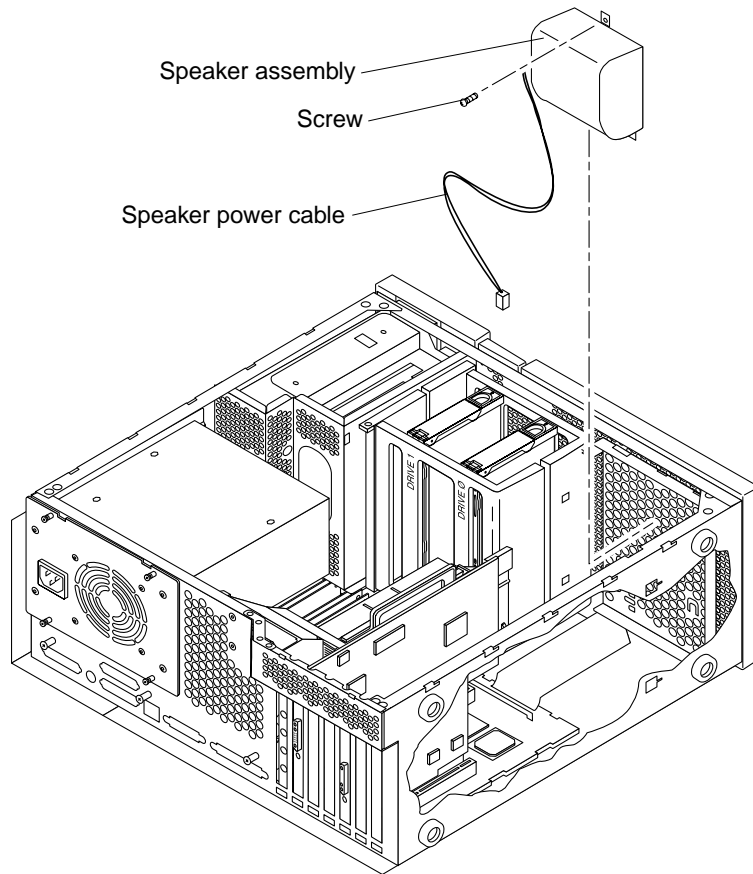

FIGURE 8-9 Removing and Replacing the Speaker Assembly

8.7.2 Replacing the Speaker Assembly



Caution – Use proper ESD grounding techniques when handling components. Wear an antistatic wrist strap and use an ESD-protected mat. Store ESD-sensitive components in antistatic bags before placing them on any surface.

1. Position the speaker assembly in the chassis (FIGURE 8-9).
2. Connect the speaker power cable to the motherboard.
3. Using a number 2 Phillips screwdriver, replace the screw securing the speaker assembly to the chassis.

4. Replace the PCI fan assembly.

See Section 8.2.2 “Replacing the PCI Fan Assembly” on page 8-7.

5. Connect the AC power cord.

6. Detach the wrist strap.

7. Replace the side access cover.

See Section 7.3 “Replacing the Side Access Cover” on page 7-5.

8. Power on the system unit.

See Section 6.1 “Powering On the System Unit” on page 6-1.

8.8 DC Switch Assembly

To remove and replace the DC switch assembly, proceed as follows.

8.8.1 Removing the DC Switch Assembly

1. Power off the system unit.

See Section 6.2 “Powering Off the System Unit” on page 6-3.

2. Remove the side access cover.

See Section 7.1 “Removing the Side Access Cover” on page 7-1.



Caution – Use proper ESD grounding techniques when handling components. Wear an antistatic wrist strap and use an ESD-protected mat. Store ESD-sensitive components in antistatic bags before placing them on any surface.

3. Attach the wrist strap.

See Section 7.2 “Attaching the Wrist Strap” on page 7-4.

4. Remove the bezel.

5. Using a number 2 Phillips screwdriver, remove the four screws securing the front panel to the chassis. Remove the front panel.

6. Remove the SCSI drive bay.

See Section 8.3.1 “Removing the SCSI Drive Bay” on page 8-7.

7. Remove the PCI fan assembly.

See Section 8.2.1 “Removing the PCI Fan Assembly” on page 8-5.

8. Remove the DC switch assembly as follows (FIGURE 8-10):

- a. Using a small flat-blade screwdriver, press the detent tab on one side of the DC switch assembly while pushing the switch toward the front.**
- b. Repeat Step 8-a for the other side of the DC switch assembly.**
- c. Continue from side-to-side to press the detent tab and pushing the DC switch assembly toward the front until the DC switch assembly can be removed from the housing.**
- d. Disconnect the DC switch assembly DC power connector from motherboard connector J3504.**
- e. Remove the SCSI drive.**

See Section 8.3.1 “Removing the SCSI Drive Bay” on page 8-7.
- f. Remove the DC switch assembly through the chassis front.**

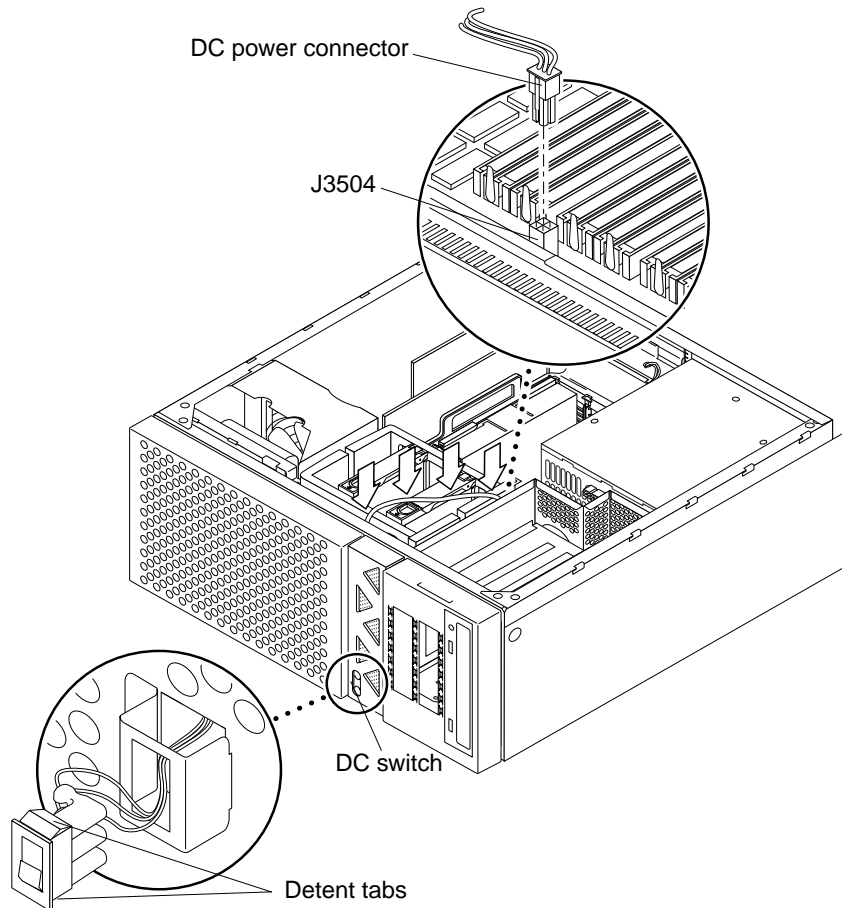

FIGURE 8-10 Removing and Replacing the DC Switch Assembly

8.8.2

Replacing the DC Switch Assembly



Caution – Use proper ESD grounding techniques when handling components. Wear an antistatic wrist strap and use an ESD-protected mat. Store ESD-sensitive components in antistatic bags before placing them on any surface.

1. **Replace the DC switch assembly as follows (FIGURE 8-10):**
 - a. **Feed the DC switch assembly power connector through the chassis front.**
 - b. **Position the DC power connector adjacent to motherboard connector J3504.**

- c. **Connect the DC switch assembly power connector to motherboard connector J3504.**
- d. **Position the DC switch assembly into the chassis housing and snap it into place.**
2. **Replace the SCSI drive bay.**
See Section 8.3.2 “Replacing the SCSI Drive Bay” on page 8-9.
3. **Replace the PCI fan assembly.**
See Section 8.2.2 “Replacing the PCI Fan Assembly” on page 8-7.
4. **Position the front panel. Using a number 2 Phillips screwdriver, replace the four screws securing the front panel to the chassis.**
5. **Replace the bezel.**
6. **Connect the AC power cord.**
7. **Detach the wrist strap.**
8. **Replace the side access cover.**
See Section 7.3 “Replacing the Side Access Cover” on page 7-5.
9. **Power on the system unit.**
See Section 6.1 “Powering On the System Unit” on page 6-1.

8.9 Shroud Assembly

A one-piece shroud assembly contains a non-removable fan that provides CPU cooling. Unlike the one-piece shroud assembly, a two-piece shroud assembly allows for the removal and replacement of the fan. To remove and replace the two-piece shroud assembly, refer to Section 8.9.2 “Two-Piece Shroud Assembly” on page 8-28. To remove and replace the two-piece shroud fan assembly, refer to Section 8.9.3 “Two-Piece Shroud Fan Assembly” on page 8-30. To remove and replace the one-piece shroud assembly, proceed as follows.

8.9.1 One-Piece Shroud Assembly

To remove and replace the one-piece shroud assembly, proceed as follows.

8.9.1.1 Removing the One-Piece Shroud Assembly

1. Remove the motherboard.

See Section 10.7.1 “Removing the Motherboard” on page 10-19.

2. Remove the following from the motherboard:

a. CPU module.

See Section 10.1.1 “Removing the CPU Module” on page 10-2.

b. DIMMs.

See Section 10.5.1 “Removing a DIMM” on page 10-13.

3. Disconnect the one-piece shroud assembly from the motherboard as follows (FIGURE 8-11 and FIGURE 8-12):

a. Disconnect the CPU fan assembly power cable from the motherboard connector J2601.

b. Unlatch the shroud-to-PCI bracket latch.

c. Flip the motherboard over. Dislodge the three retaining clips securing the shroud assembly to the motherboard.

4. Separate the shroud assembly from the motherboard.

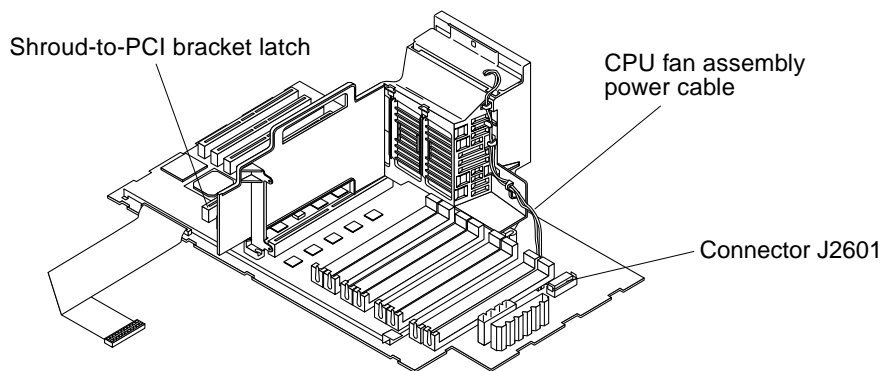

FIGURE 8-11 Removing and Replacing the One-Piece Shroud Assembly (Part 1 of 2)

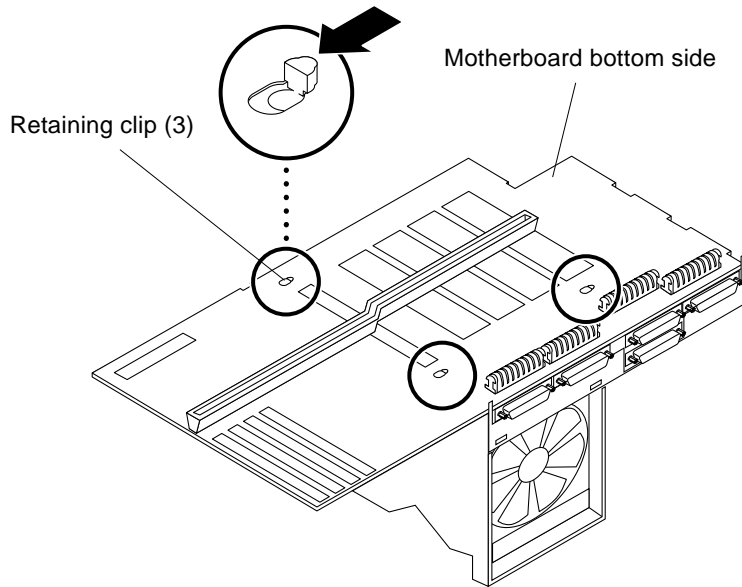

FIGURE 8-12 Removing and Replacing the One-Piece Shroud Assembly (Part 2 of 2)

8.9.1.2

Replacing the One-Piece Shroud Assembly



Caution – Use proper ESD grounding techniques when handling components. Wear an antistatic wrist strap and use an ESD-protected mat. Store ESD-sensitive components in antistatic bags before placing them on any surface.

1. Join the one-piece shroud assembly to the motherboard.
2. Connect the one-piece shroud assembly to the motherboard as follows:
 - a. Position the shroud assembly and the motherboard, ensuring that the shroud assembly retaining clips are aligned with the motherboard retaining clip holes.
 - b. Secure each shroud assembly retaining clip by pressing down on the motherboard around the area of each retaining clip (FIGURE 8-12).
 - c. Slowly flip the motherboard over, ensuring that the shroud assembly and motherboard connection is secure.
 - d. Latch the shroud-to-PCI bracket latch.

- e. **Connect the CPU fan assembly power cable to the motherboard connector J2601**
(FIGURE 8-11).
- 3. Replace the following into the motherboard:**
 - a. **DIMMs.**
See Section 10.5.2 “Replacing a DIMM” on page 10-14.
 - b. **CPU module.**
See Section 10.1.2 “Replacing the CPU Module” on page 10-3.
- 4. Replace the motherboard.**
See Section 10.7.2 “Replacing the Motherboard” on page 10-22.

8.9.2 Two-Piece Shroud Assembly

To remove and replace the two-piece shroud assembly, proceed as follows.

8.9.2.1 Removing the Two-Piece Shroud Assembly

- 1. Power off the system unit.**
See Section 6.2 “Powering Off the System Unit” on page 6-3.
- 2. Remove the side access cover.**
See Section 7.1 “Removing the Side Access Cover” on page 7-1.



Caution – Use proper ESD grounding techniques when handling components. Wear an antistatic wrist strap and use an ESD-protected mat. Store ESD-sensitive components in antistatic bags before placing them on any surface.

- 3. Attach the wrist strap.**
See Section 7.2 “Attaching the Wrist Strap” on page 7-4.
- 4. Remove the power supply.**
See Section 8.1.1 “Removing the Power Supply” on page 8-2.
- 5. Remove the CPU module.**
See Section 10.1.1 “Removing the CPU Module” on page 10-2.
- 6. Remove the DIMMs.**
See Section 10.5.1 “Removing a DIMM” on page 10-13.

7. Disconnect the shroud assembly as follows (FIGURE 8-13):
 - a. Disconnect the CPU fan assembly power cable from the motherboard connector J2601.
 - b. Using a number 2 Phillips screwdriver, loosen the captive screws securing the shroud assembly and motherboard to the chassis (the captive screws will pop up).
 - c. Lift the shroud assembly locking lever to unlock the shroud assembly from the motherboard. Unlatch the shroud-to-PCI bracket latch.
8. Remove the shroud assembly from the motherboard.

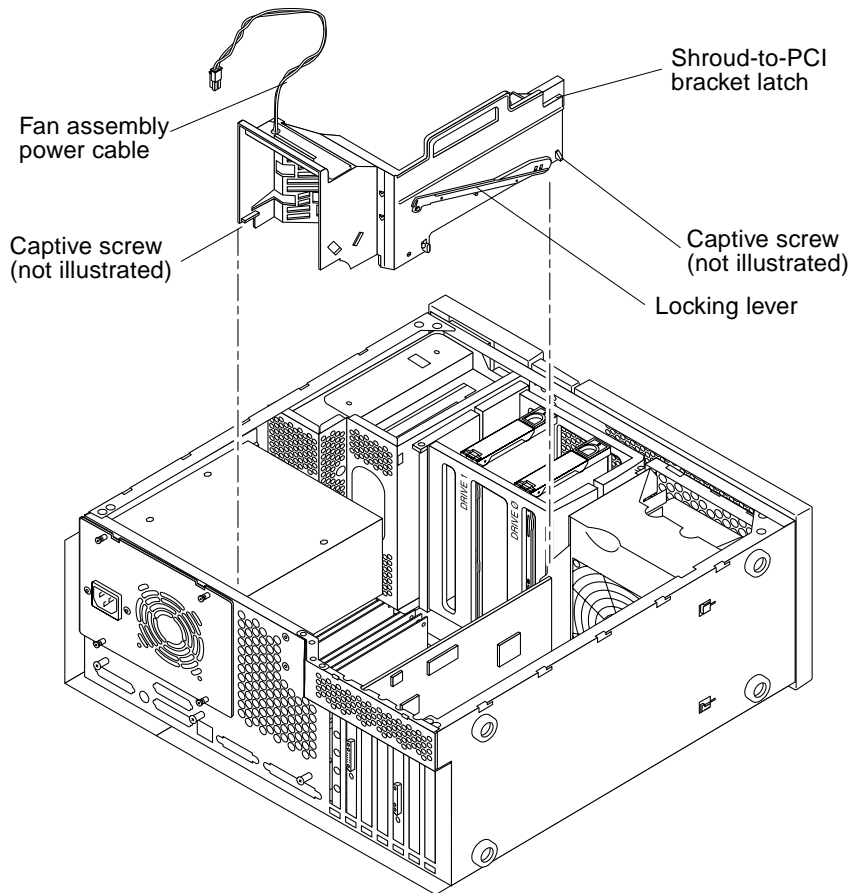

FIGURE 8-13 Removing and Replacing the Two-Piece Shroud Assembly

8.9.2.2

Replacing the Two-Piece Shroud Assembly



Caution – Use proper ESD grounding techniques when handling components. Wear an antistatic wrist strap and use an ESD-protected mat. Store ESD-sensitive components in antistatic bags before placing them on any surface.

1. **Join the shroud assembly onto the motherboard.**
2. **Connect the shroud assembly as follows (FIGURE 8-13):**
 - a. **Lower the locking lever to lock the shroud assembly to the motherboard. Latch the shroud-to-PCI bracket latch.**
 - b. **Using a number 2 Phillips screwdriver, tighten the captive screws securing the shroud assembly and motherboard to the chassis.**
 - c. **Connect the power cable to the motherboard connector J2601.**
3. **Replace the DIMMs.**

See Section 10.5.2 “Replacing a DIMM” on page 10-14.
4. **Replace the CPU module.**

See Section 10.1.2 “Replacing the CPU Module” on page 10-3.
5. **Replace the power supply.**

See Section 8.1.2 “Replacing the Power Supply” on page 8-4.
6. **Connect the AC power cord to the system unit.**
7. **Detach the wrist strap.**
8. **Replace the side access cover.**

See Section 7.3 “Replacing the Side Access Cover” on page 7-5.
9. **Power on the system unit.**

See Section 6.1 “Powering On the System Unit” on page 6-1.

8.9.3

Two-Piece Shroud Fan Assembly

To remove and replace the two-piece shroud fan assembly, proceed as follows.

8.9.3.1 Removing the Two-Piece Shroud Fan Assembly

1. Power off the system unit.

See Section 6.2 “Powering Off the System Unit” on page 6-3.

2. Remove the side access cover.

See Section 7.1 “Removing the Side Access Cover” on page 7-1.



Caution – Use proper ESD grounding techniques when handling components. Wear an antistatic wrist strap and use an ESD-protected mat. Store ESD-sensitive components in antistatic bags before placing them on any surface.

3. Attach the wrist strap.

See Section 7.2 “Attaching the Wrist Strap” on page 7-4.

4. Disconnect the fan assembly as follows (FIGURE 8-14):

- a. **Disconnect the fan assembly power cable from the motherboard connector J2601.**
- b. **Unroute the fan assembly power cable from the five cable clips.**
- c. **Using a number 2 Phillips screwdriver, press the snap catch to release the fan assembly from the two-piece shroud assembly.**
- d. **Using the metal handle, lift the fan assembly from the two-piece shroud assembly.**

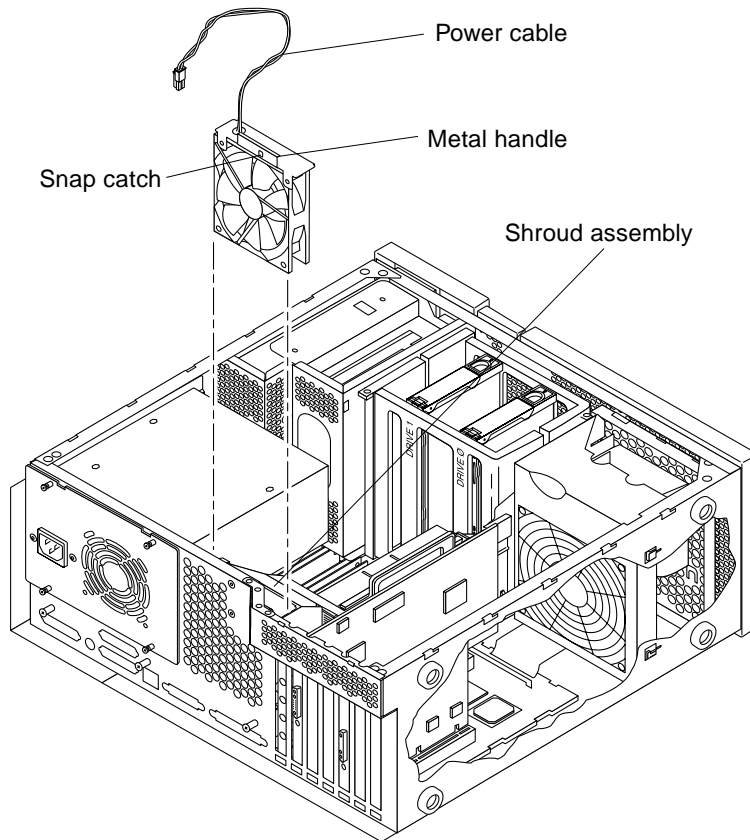

FIGURE 8-14 Removing and Replacing the Two-Piece Shroud Fan Assembly

8.9.3.2

Replacing the Two-Piece Shroud Fan Assembly



Caution – Use proper ESD grounding techniques when handling components. Wear an antistatic wrist strap and use an ESD-protected mat. Store ESD-sensitive components in antistatic bags before placing them on any surface.

1. **Connect the fan assembly as follows (FIGURE 8-14):**
 - a. **Using the metal handle, insert the fan assembly into the two-piece shroud assembly, firmly compressing the foam until the catch snap activates into the square opening.**
 - b. **Route the fan assembly power cable through the five cable clips.**

Storage Devices

This chapter describes how to remove and replace the Ultra 30 storage devices.

This chapter contains the following topics:

- Section 9.1 “Hard Drive” on page 9-1
- Section 9.2 “Removable Media Assembly Drive” on page 9-4

Note – Removal and replacement of selected storage devices are also illustrated with photographs and audio/visual instructions on the *Sun Ultra 30 ShowMe How Multimedia Documentation*, part number 704-5681.

9.1 Hard Drive

To remove and replace a hard drive, proceed as follows.

9.1.1 Removing a Hard Drive

1. Power off the system unit.

See Section 6.2 “Powering Off the System Unit” on page 6-3.

2. Remove the side access cover.

See Section 7.1 “Removing the Side Access Cover” on page 7-1.



Caution – Use proper ESD grounding techniques when handling components. Wear an antistatic wrist strap and use an ESD-protected mat. Store ESD-sensitive components in antistatic bags before placing them on any surface.

3. Attach the wrist strap.

See Section 7.2 “Attaching the Wrist Strap” on page 7-4.

4. Remove the hard drive as follows (FIGURE 9-1):

a. Push the handle latch to open the hard drive handle.

b. Extend the hard drive handle to disconnect the hard drive from the system.

c. Holding the drive handle, remove the hard drive from the drive bay.

5. Place the hard drive on an antistatic mat.

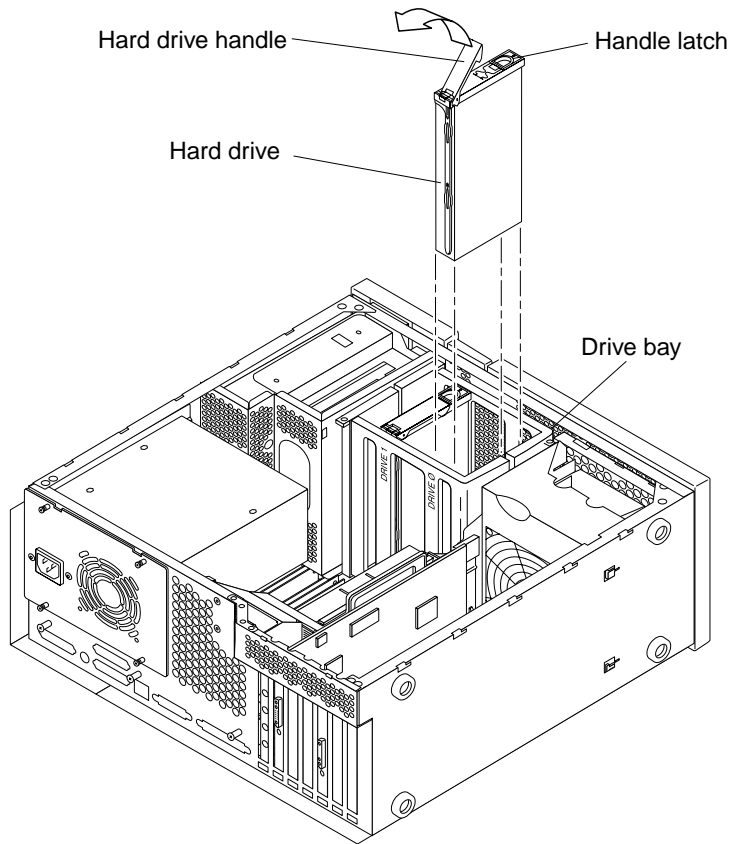

FIGURE 9-1 Removing and Replacing a Hard Drive

9.1.2 Replacing a Hard Drive



Caution – Use proper ESD grounding techniques when handling components. Wear an antistatic wrist strap and use an ESD-protected mat. Store ESD-sensitive components in antistatic bags before placing them on any surface.

1. **Replace the hard drive as follows (FIGURE 9-1):**
 - a. **Holding the drive handle, insert the hard drive into the drive bay.**
 - b. **Push the front of the hard drive to connect it to the SCSI bus.**
 - c. **Close the hard drive handle to lock the hard drive into the system.**

2. **Connect the AC power cord to the system unit.**
3. **Detach the wrist strap.**
4. **Replace the side access cover.**
See Section 7.3 “Replacing the Side Access Cover” on page 7-5.
5. **Power-on the system.**
See Section 6.1 “Powering On the System Unit” on page 6-1.

9.2 Removable Media Assembly Drive

To remove and replace a removable media assembly (RMA) drive, it is necessary to remove and replace the RMA. To remove and replace the RMA and a RMA drive, refer to FIGURE 9-2 and FIGURE 9-3 and proceed as follows.

Note – An RMA drive can include a CD-ROM drive, 4-mm tape drive, 8-mm tape drive, a diskette drive, and any other 3.5-inch device, such as a second diskette drive or a peripheral component interconnect (PCI)-connected device.

9.2.1 Removing the RMA

1. **Power off the system.**
See Section 6.2 “Powering Off the System Unit” on page 6-3.
2. **Remove the side access cover.**
See Section 7.1 “Removing the Side Access Cover” on page 7-1.



Caution – Use proper ESD grounding techniques when handling components. Wear an antistatic wrist strap and use an ESD-protected mat. Store ESD-sensitive components in antistatic bags before placing them on any surface.

3. **Attach the wrist strap.**
See Section 7.2 “Attaching the Wrist Strap” on page 7-4.
4. **Remove the RMA as follows (FIGURE 9-2):**
 - a. **Remove the front bezel.**

- b. Using a number 2 Phillips screwdriver, loosen the two captive screws securing the RMA to the chassis.
 - c. Partially remove the RMA from the chassis.
 - d. Disconnect the peripheral cables and the power cables from the drives (not illustrated).
 - e. Remove the RMA from the chassis.
5. Place the RMA on an antistatic mat.

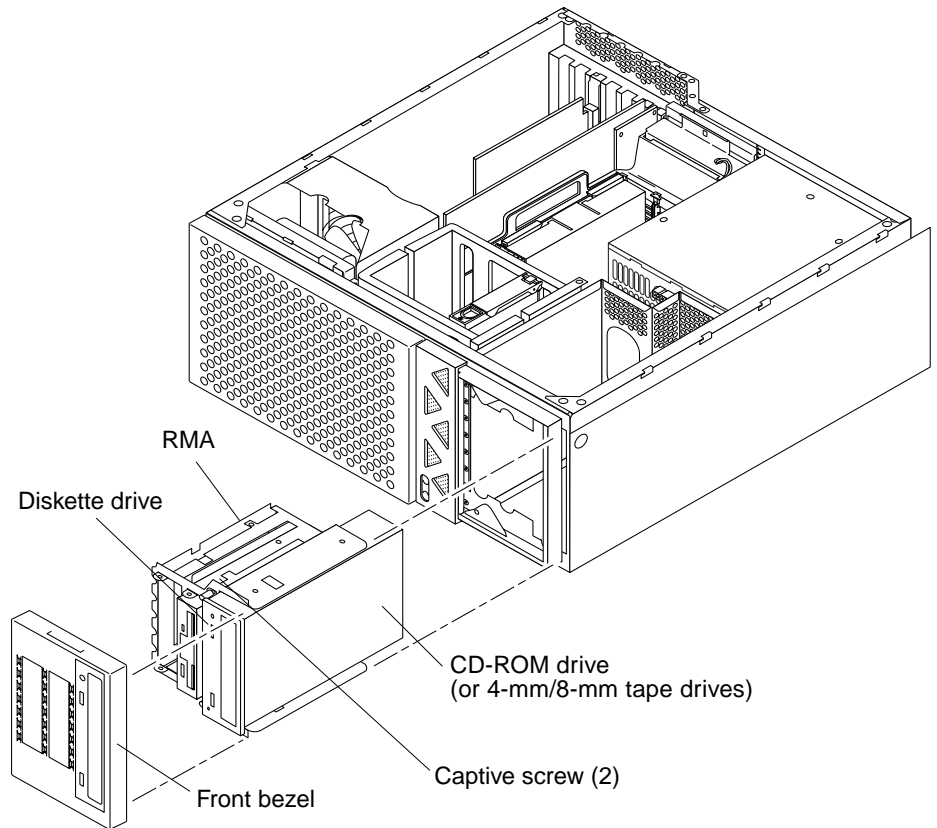

FIGURE 9-2 Removing and Replacing the RMA Drive (Part 1 of 2)

9.2.2

Removing a CD-ROM Drive or 4-mm/8-mm Tape Drive



Caution – Use proper ESD grounding techniques when handling components. Wear an antistatic wrist strap and use an ESD-protected mat. Store ESD-sensitive components in antistatic bags before placing them on any surface.

1. Position the RMA on a flat surface so that the CD-ROM drive or tape drive is flat (FIGURE 9-3).

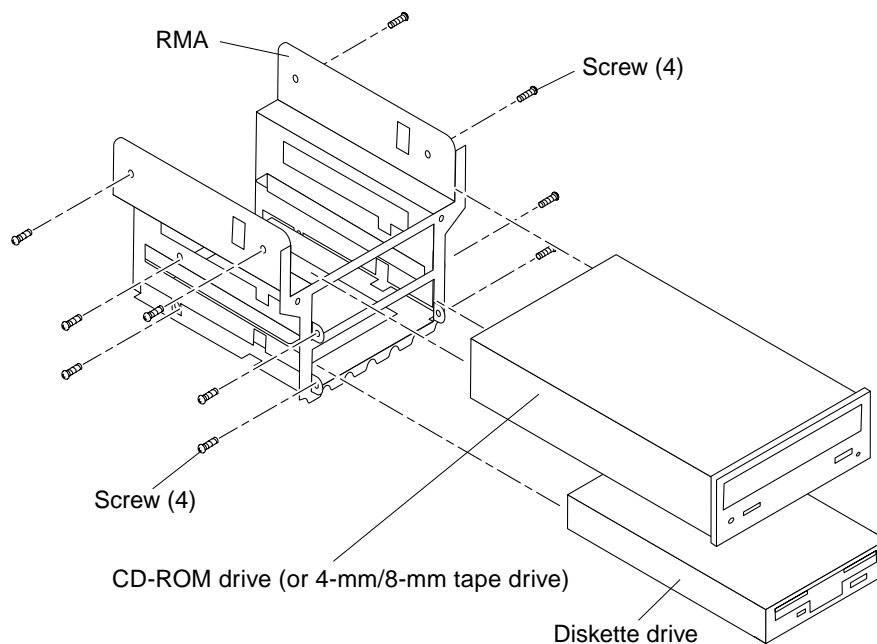

FIGURE 9-3 Removing and Replacing the RMA Drive (Part 2 of 2)

2. Using a number 2 Phillips screwdriver, remove the four screws securing the CD-ROM drive or tape drive to the RMA.
3. Remove the CD-ROM drive or tape drive and place it on an antistatic mat.

9.2.3 Replacing a CD-ROM Drive or 4-mm/8-mm Tape Drive



Caution – Use proper ESD grounding techniques when handling components. Wear an antistatic wrist strap and use an ESD-protected mat. Store ESD-sensitive components in antistatic bags before placing them on any surface.

1. **Position the CD-ROM drive or tape drive into the RMA (FIGURE 9-3).**
2. **Using a number 2 Phillips screwdriver, replace the four screws securing the CD-ROM drive or tape drive to the RMA.**
3. **Replace the RMA.**

See Section 9.2.6 “Replacing the RMA” on page 9-8

9.2.4 Removing a Diskette Drive



Caution – Use proper ESD grounding techniques when handling components. Wear an antistatic wrist strap and use an ESD-protected mat. Store ESD-sensitive components in antistatic bags before placing them on any surface.

1. **Position the RMA on a flat surface so that the diskette drive is flat (FIGURE 9-3).**
2. **Using a number 2 Phillips screwdriver, remove the four screws securing the diskette drive to the RMA.**
3. **Remove the diskette drive and place it on an antistatic mat.**

9.2.5 Replacing a Diskette Drive



Caution – Use proper ESD grounding techniques when handling components. Wear an antistatic wrist strap and use an ESD-protected mat. Store ESD-sensitive components in antistatic bags before placing them on any surface.

1. **Position the diskette drive into the RMA (FIGURE 9-3).**
2. **Using a number 2 Phillips screwdriver, replace the four screws securing the diskette drive to the RMA.**

3. Replace the RMA.

See Section 9.2.6 “Replacing the RMA” on page 9-8

9.2.6 Replacing the RMA



Caution – Use proper ESD grounding techniques when handling components. Wear an antistatic wrist strap and use an ESD-protected mat. Store ESD-sensitive components in antistatic bags before placing them on any surface.

1. Replace the RMA as follows (FIGURE 9-2):

- a. Position the RMA into the chassis, connect the rear cable connectors as required.
- b. Using a number 2 Phillips screwdriver, tighten the captive screws securing the RMA to the chassis.

2. Replace the front bezel.

3. Connect the AC power cord to the system unit.

4. Detach the wrist strap.

5. Replace the side access cover.

See Section 7.3 “Replacing the Side Access Cover” on page 7-5.

6. Power on the system unit.

See Section 6.1 “Powering On the System Unit” on page 6-1.

Motherboard and Component Replacement

This chapter describes how to remove and replace the Ultra 30 motherboard and motherboard components.

This chapter contains the following topics:

- Section 10.1 “CPU Module” on page 10-1
- Section 10.2 “NVRAM/TOD” on page 10-4
- Section 10.3 “PCI Card” on page 10-6
- Section 10.4 “UPA Graphics Card” on page 10-9
- Section 10.5 “DIMM” on page 10-12
- Section 10.6 “Audio Card” on page 10-16
- Section 10.1 “CPU Module” on page 10-1

Note – Removal and replacement of the motherboard and motherboard components are also illustrated with photographs and audio/visual instructions on the *Ultra 30 ShowMe How Multimedia Documentation*, part number 704-5681.

10.1 CPU Module

To remove and replace the CPU module, proceed as follows.

10.1.1 Removing the CPU Module

1. Power off the system unit.

See Section 6.2 “Powering Off the System Unit” on page 6-3.

2. Remove the side access cover.

See Section 7.1 “Removing the Side Access Cover” on page 7-1.

3. Attach a wrist strap.

See Section 7.2 “Attaching the Wrist Strap” on page 7-4.



Caution – Use proper ESD grounding techniques when handling components. Wear an antistatic wrist strap and use an ESD-protected mat. Store ESD-sensitive components in antistatic bags before placing them on any surface.

4. Remove the CPU module as follows (FIGURE 10-1):

a. Using the thumbs of both hands, simultaneously lift the two levers on the CPU module up and to the side to approximately 135 degrees.

b. Lift the CPU module up until it clears the shroud assembly and system chassis.

5. Place the CPU module on an antistatic mat.

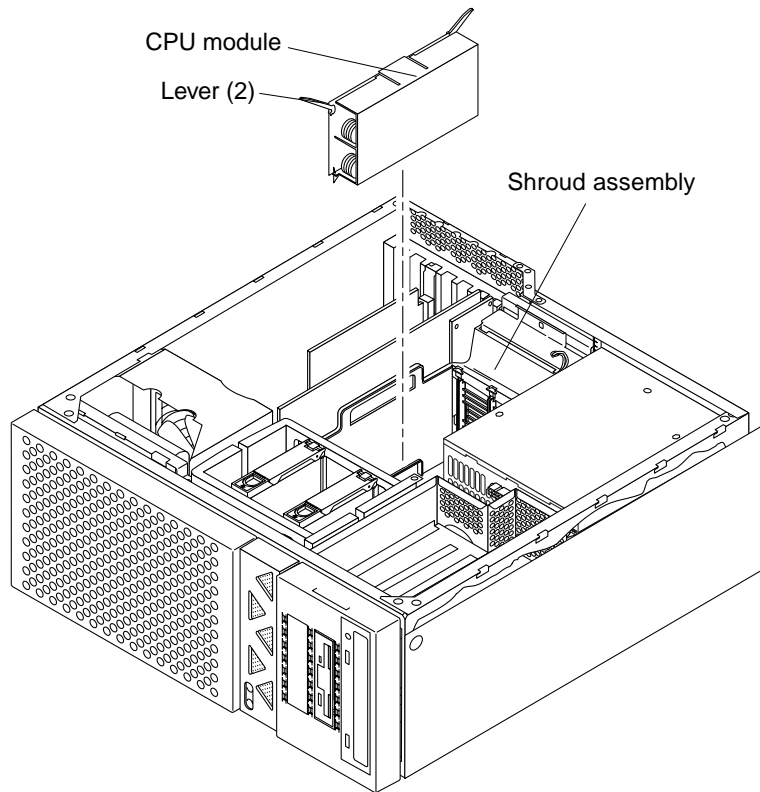

FIGURE 10-1 Removing and Replacing the CPU Module

10.1.2 Replacing the CPU Module



Caution – Use proper ESD grounding techniques when handling components. Wear an antistatic wrist strap and use an ESD-protected mat. Store ESD-sensitive components in antistatic bags before placing them on any surface.

1. **Replace the CPU module as follows (FIGURE 10-1):**
 - a. **On the antistatic mat, hold the CPU module in an upright position with the plastic surface facing you.**
 - b. **Move the levers on the CPU module to the 135-degree position.**

- c. **Lower the CPU module along the vertical plastic guides until the module touches the motherboard slot socket. Lock the CPU module in place as follows (FIGURE 10-1):**
 - i. **With both hands, simultaneously turn and press the levers down to the fully horizontal position.**
 - ii. **Firmly press the module down into the socket until it is fully seated and the levers are fully locked.**
2. **Connect the AC power cord to the system unit.**
3. **Detach the wrist strap.**
4. **Replace the side access cover.**

See Section 7.3 “Replacing the Side Access Cover” on page 7-5.
5. **Power on the system.**

See Section 6.1 “Powering On the System Unit” on page 6-1.

10.2 NVRAM/TOD

To remove and replace the NVRAM/TOD, proceed as follows.

10.2.1 Removing the NVRAM/TOD

1. **Power off the system unit.**

See Section 6.2 “Powering Off the System Unit” on page 6-3.
2. **Remove the side access cover.**

See Section 7.1 “Removing the Side Access Cover” on page 7-1.
3. **Attach a wrist strap.**

See Section 7.2 “Attaching the Wrist Strap” on page 7-4.



Caution – Use proper ESD grounding techniques when handling components. Wear an antistatic wrist strap and use an ESD-protected mat. Store ESD-sensitive components in antistatic bags before placing them on any surface.

4. Remove the power supply.

See Section 8.1.1 “Removing the Power Supply” on page 8-2.

5. Remove the NVRAM/TOD as follows (FIGURE 10-2):

a. Locate the NVRAM/TOD and carrier on the motherboard.

b. Grasp the NVRAM/TOD carrier at each end and pull straight up.

Note – Gently wiggle the NVRAM/TOD as necessary.

6. Place the NVRAM/TOD and carrier on an antistatic mat.

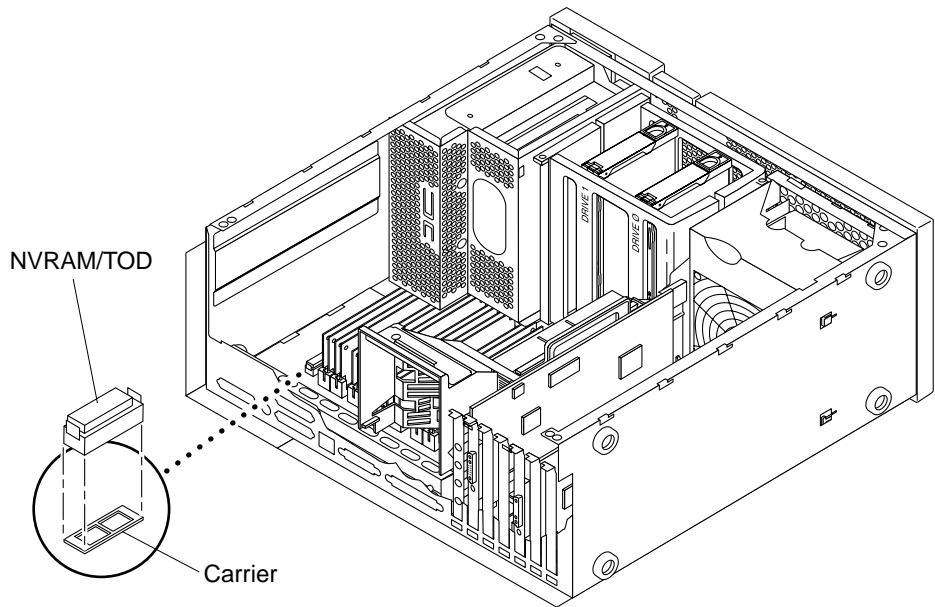

FIGURE 10-2 Removing and Replacing the NVRAM/TOD

10.2.2 Replacing the NVRAM/TOD



Caution – Use proper ESD grounding techniques when handling components. Wear an antistatic wrist strap and use an ESD-protected mat. Store ESD-sensitive components in antistatic bags before placing them on any surface.

1. Replace the NVRAM/TOD as follows (FIGURE 10-2):

- a. **Position the NVRAM/TOD and carrier on the motherboard.**
- b. **Carefully insert the NVRAM/TOD and carrier into the socket.**

Note – The carrier is keyed so the NVRAM/TOD can be installed only one way.

- c. **Push the NVRAM/TOD into the carrier until properly seated.**
2. **Replace the power supply.**
See Section 8.1.2 “Replacing the Power Supply” on page 8-4.
3. **Connect the AC power cord to the system unit.**
4. **Detach the wrist strap.**
5. **Replace the side access cover.**
See Section 7.3 “Replacing the Side Access Cover” on page 7-5.
6. **Power on the system unit.**
See Section 6.1 “Powering On the System Unit” on page 6-1.

10.3 PCI Card

To remove and replace a PCI card, proceed as follows.

10.3.1 Removing a PCI Card

1. **Power off the system unit.**
See Section 6.2 “Powering Off the System Unit” on page 6-3.
2. **Disconnect cables from the PCI card being removed.**
3. **Remove the side access cover.**
See Section 7.1 “Removing the Side Access Cover” on page 7-1.



Caution – Use proper ESD grounding techniques when handling components. Wear an antistatic wrist strap and use an ESD-protected mat. Store ESD-sensitive components in antistatic bags before placing them on any surface.

4. Attach the wrist strap.

See Section 7.2 “Attaching the Wrist Strap” on page 7-4.

5. Remove the PCI card as follows (FIGURE 10-3):

- a. Using a Phillips screwdriver, remove the screw securing the PCI card bracket tab to the system chassis.**



Caution – Avoid damaging the connector by not applying force to one end or one side of the board.

- b. At the two upper corners of the PCI card, pull the card straight up from the slot.**

- c. Remove the PCI card.**

6. Place the PCI card on an antistatic mat.

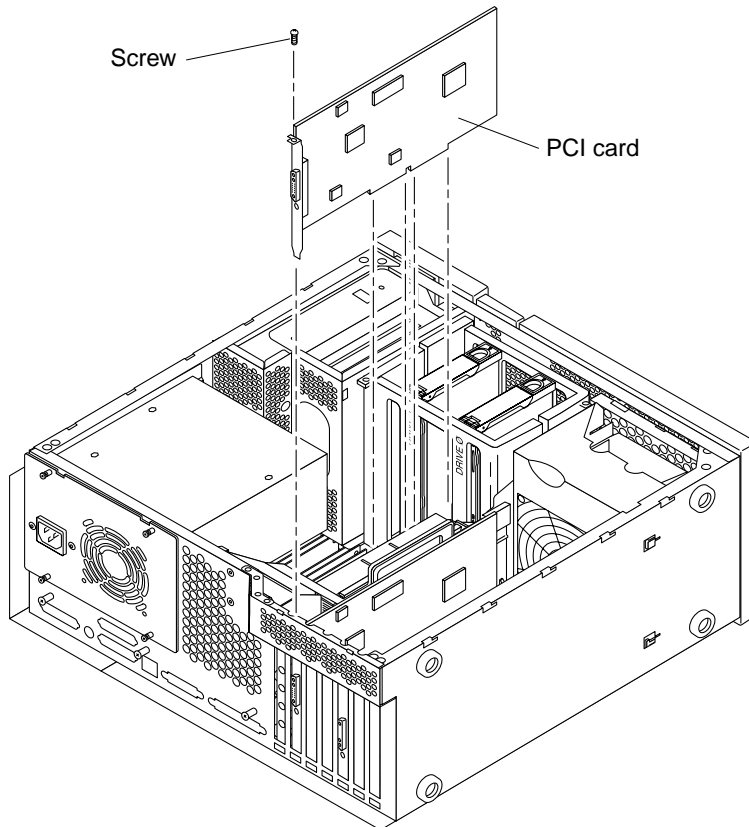

FIGURE 10-3 Removing and Replacing a PCI Card

10.3.2 Replacing a PCI Card



Caution – Use proper ESD grounding techniques when handling components. Wear an antistatic wrist strap and use an ESD-protected mat. Store ESD-sensitive components in antistatic bags before placing them on any surface.

Note – Read the PCI card product guide for information about jumper or switch settings, slot requirements, and required tools.

1. **Replace the PCI card as follows (FIGURE 10-3):**
 - a. **Position the PCI card into the chassis.**
 - b. **Lower the PCI card connector so that it touches its associated PCI card slot on the motherboard.**
 - c. **Guide the PCI card back panel into the chassis back panel.**
 - d. **At the two upper corners of the card, push the card straight down into the slot until the card is fully seated.**
 - e. **Using a Phillips screwdriver, replace the screw securing the card bracket tab to the system chassis.**
2. **Connect the AC power cord to the system unit.**
3. **Detach the wrist strap.**
4. **Replace the side access cover.**

See Section 7.3 “Replacing the Side Access Cover” on page 7-5.
5. **Connect all cables to the PCI slots.**
6. **Power on the system unit.**

See Section 6.1 “Powering On the System Unit” on page 6-1.

10.4 UPA Graphics Card

Note – If the UPA graphics card is an M6-type graphics card, it may be necessary to remove and replace the UPA graphics card cable assembly that is used for stereo applications. To remove the UPA graphics card cable assembly, see Section 8.4.5 “Removing the UPA Graphics Card Cable Assembly” on page 8-13. To replace the UPA graphics card cable assembly, see Section 8.4.6 “Replacing the UPA Graphics Card Cable Assembly” on page 8-16.

To remove and replace a UPA graphics card, proceed as follows.

10.4.1 Removing a UPA Graphics Card

1. Power off the system unit.

See Section 6.2 “Powering Off the System Unit” on page 6-3.

2. Disconnect the video cable from the graphics card video connector.

3. Remove the side access cover.

See Section 7.1 “Removing the Side Access Cover” on page 7-1.



Caution – Use proper ESD grounding techniques when handling components. Wear an antistatic wrist strap and use an ESD-protected mat. Store ESD-sensitive components in antistatic bags before placing them on any surface.

4. Attach the wrist strap.

See Section 7.2 “Attaching the Wrist Strap” on page 7-4.

5. Remove a UPA graphics card as follows (FIGURE 10-4):

Note – If the UPA graphics card being removed is an M6-type UPA graphics card, refer to Section 8.4.5 “Removing the UPA Graphics Card Cable Assembly” on page 8-13.

a. Using a Phillips screwdriver, remove the screw securing the graphics card bracket tab to the system chassis.



Caution – Avoid applying force to one end or one side of the board or connector damage may occur.

- b. At the two upper corners of the graphics card, pull the card straight up from the slot.
 - c. Remove the UPA graphics card.
6. Place the UPA graphics card on an antistatic mat.

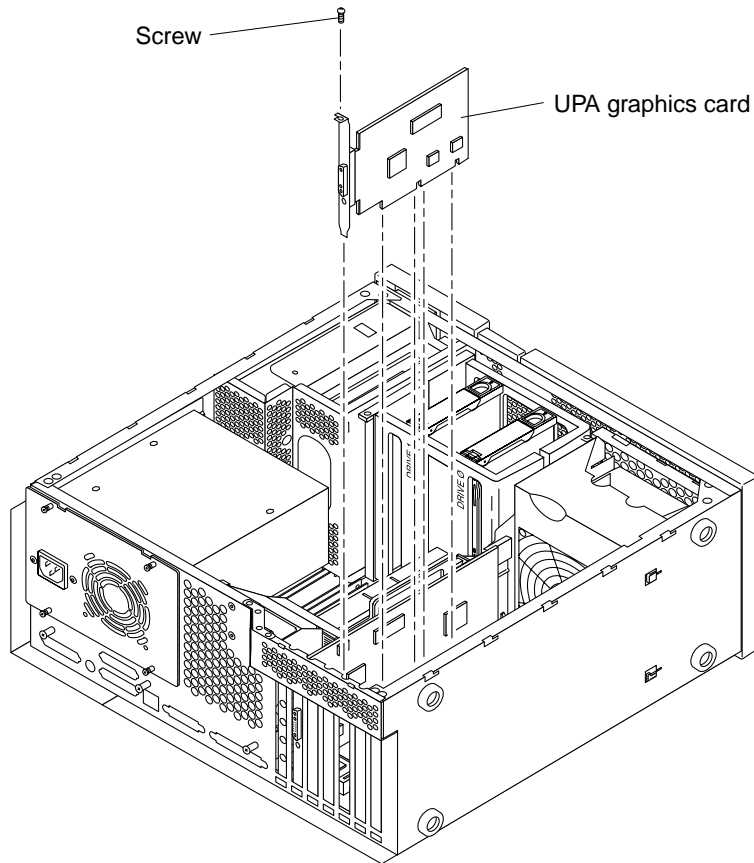

FIGURE 10-4 Removing and Replacing a UPA Graphics Card

10.4.2 Replacing a UPA Graphics Card



Caution – Use proper ESD grounding techniques when handling components. Wear an antistatic wrist strap and use an ESD-protected mat. Store ESD-sensitive components in antistatic bags before placing them on any surface.

1. **Replace the UPA graphics card as follows (FIGURE 10-4):**
 - a. **Position the UPA graphics card into the chassis.**
 - b. **Guide the UPA graphics card back panel into the chassis back panel.**
 - c. **Lower the UPA graphics card connector so that it touches its associated UPA card slot on the motherboard.**



Caution – Avoid damaging the connector by not applying force to one end or one side of the board.

Note – The UPA graphics card connector is a double-row connector that requires two levels of insertion. When installing the graphics card, ensure that the connector is fully seated into the slot.

- d. **At the two upper corners of the card, push the card straight down into the slot until the card is fully seated.**
- e. **Using a Phillips screwdriver, replace the screw securing the card bracket tab to the system chassis.**

Note – If the UPA graphics card being replaced is an M6-type UPA graphics card, refer to Section 8.4.6 “Replacing the UPA Graphics Card Cable Assembly” on page 8-16.

2. **Connect the AC power cord to the system unit.**
3. **Detach the wrist strap.**
4. **Replace the side access cover.**

See Section 7.3 “Replacing the Side Access Cover” on page 7-5.
5. **Connect the video cable to the graphics card video connector.**
6. **Power on the system unit.**

See Section 6.1 “Powering On the System Unit” on page 6-1.

10.5 DIMM

To remove and replace a DIMM, proceed as follows.



Caution – DIMMs consist of electronic components that are extremely sensitive to static electricity. Ordinary amounts of static electricity from clothing or work environment can destroy the DIMM.



Caution – When removing a DIMM, an identical replacement is required. The replacement DIMM must be inserted into the same socket as the removed DIMM.



Caution – Each DIMM bank must contain at least two DIMMs of equal density (for example: two 32-Mbyte DIMMs) to function properly. Do not mix DIMM densities in any bank.

Note – The system unit *must* have at least two identical DIMMs installed in paired sockets of any DIMM bank. For best system performance, install four identical DIMMs. TABLE 10-1 identifies DIMM installation locations.

TABLE 10-1 DIMM Installation Locations

Bank	Slot Pairs
0	U0701, U0801, U0901, and U1001
1	U0702, U0802, U0902 and U1002
2	U0703, U0803, U0903, and U1003
3	U0704, U0804, U0904, and U1004

10.5.1 Removing a DIMM



Caution – Handle DIMMs only by the edges. Do not touch the DIMM components or metal parts. Always wear a grounding strap when handling a DIMM.

1. Power off the system unit.

See Section 6.2 “Powering Off the System Unit” on page 6-3.

2. Remove the side access cover.

See Section 7.1 “Removing the Side Access Cover” on page 7-1.



Caution – Use proper ESD grounding techniques when handling components. Wear an antistatic wrist strap and use an ESD-protected mat. Store ESD-sensitive components in antistatic bags before placing them on any surface.

3. Attach the wrist strap.

See Section 7.2 “Attaching the Wrist Strap”.

4. Remove the power supply.

See Section 8.1.1 “Removing the Power Supply” on page 8-2.

5. Locate the DIMM to be removed.

6. Push the ejection lever away from the DIMM (FIGURE 10-5).

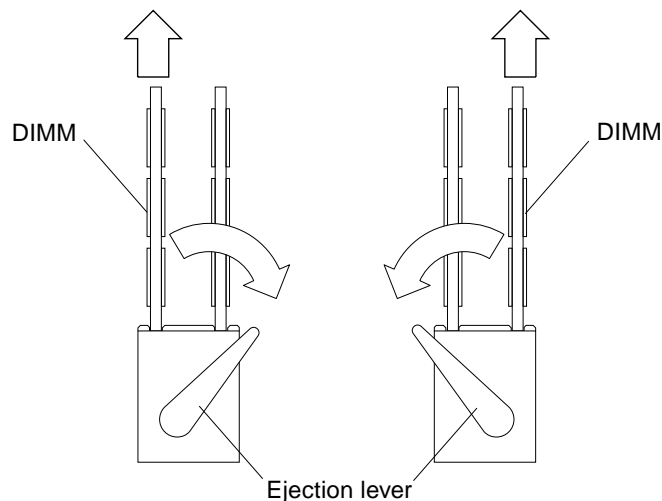

FIGURE 10-5 DIMM Ejection Lever

7. Remove the DIMM from the socket (FIGURE 10-6).
8. Place the DIMM on an antistatic mat.

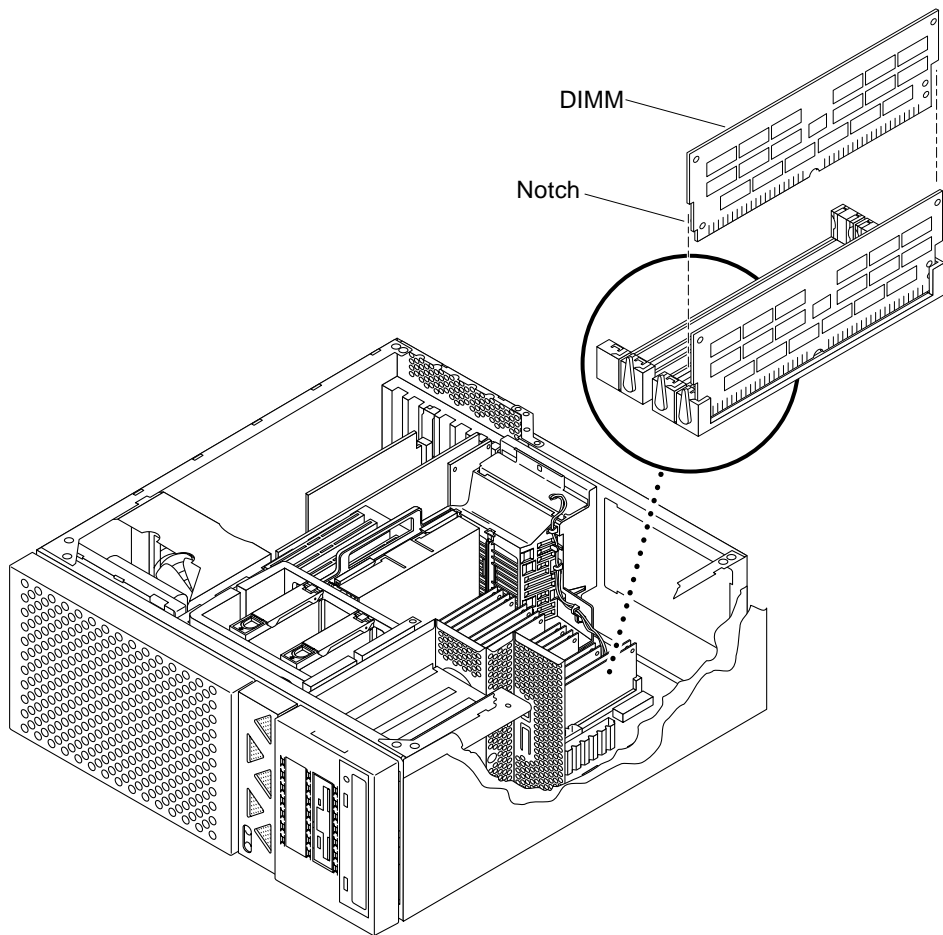

FIGURE 10-6 Removing and Replacing a DIMM

10.5.2 Replacing a DIMM



Caution – DIMMs are made of electronic components that are extremely sensitive to static electricity. Ordinary amounts of static electricity from clothing or work environment can destroy the DIMM.



Caution – Do not remove any DIMM from the antistatic container until ready to install it on the motherboard. Handle DIMMs only by their edges. Do not touch DIMM components or metal parts. Always wear a grounding strap when handling DIMMs.



Caution – Each DIMM bank must contain two DIMMs of equal density (for example two 32-Mbyte DIMMs) to function properly. Do not mix DIMM density in any bank.



Caution – Use proper ESD grounding techniques when handling components. Wear an antistatic wrist strap and use an ESD-protected mat. Store ESD-sensitive components in antistatic bags before placing them on any surface.

1. Locate the DIMM slot(s) on the motherboard where DIMMs were removed.

Note – The system unit *must* have at least two identical DIMMs installed in paired sockets of any DIMM bank. For best system performance, install four identical DIMMs. TABLE 10-1 on page 10-12 identifies DIMM installation locations.



Caution – Hold DIMMs only by the edges.

2. Remove the DIMM from the antistatic container.

3. Install the DIMM as follows (FIGURE 10-6):

- a. Position the DIMM in the socket, ensure that the notch is on the same side as the lever.
- b. Using your thumbs, press firmly on the DIMM top until the DIMM is properly seated.

Note – Proper DIMM seating is verified by a clicking sound. Ensure proper seating occurs.

4. Replace the power supply.

See Section 8.1.2 “Replacing the Power Supply” on page 8-4.

5. Connect the AC power cord to the system unit.

6. Detach the wrist strap.

7. Replace the side access cover.

See Section 7.3 “Replacing the Side Access Cover” on page 7-5.

8. Power on the system unit.

See Section 6.1 “Powering On the System Unit” on page 6-1.

10.6 Audio Card

To remove and replace the audio card, proceed as follows.

10.6.1 Removing the Audio Card

1. Power off the system unit.

See Section 6.2 “Powering Off the System Unit” on page 6-3.

2. Disconnect any audio cables from the audio card.

3. Remove the side access cover.

See Section 7.1 “Removing the Side Access Cover” on page 7-1.



Caution – Use proper ESD grounding techniques when handling components. Wear an antistatic wrist strap and use an ESD-protected mat. Store ESD-sensitive components in antistatic bags before placing them on any surface.

4. Attach the wrist strap.

See Section 7.2 “Attaching the Wrist Strap” on page 7-4.

5. Remove the audio card as follows (FIGURE 10-7):

a. Using a Phillips screwdriver, remove the screw securing the audio card bracket tab to the system chassis.



Caution – Avoid damaging the connector by not applying force to one end or one side of the board.

b. Remove the UPA graphics card(s).

See Section 10.4.1 “Removing a UPA Graphics Card” on page 10-9.

- c. At the two upper corners of the audio card, pull the card straight up from the slot.
 - d. Remove the audio card.
6. Place the audio card on an antistatic mat.

10.6.2 Replacing the Audio Card



Caution – Use proper ESD grounding techniques when handling components. Wear an antistatic wrist strap and use an ESD-protected mat. Store ESD-sensitive components in antistatic bags before placing them on any surface.

1. Replace the audio module as follows (FIGURE 10-7):
 - a. Position the audio module into the chassis.
 - b. Lower the audio module connector so that it touches its associated card slot on the motherboard.
 - c. At the two upper corners of the card, push the card straight down into the slot until the card is fully seated.
 - d. Using a Phillips screwdriver, replace the screw securing the audio module to the system chassis.
 - e. Replace the UPA graphics card(s).

See Section 10.4.2 “Replacing a UPA Graphics Card” on page 10-11.
2. Connect the AC power cord to the system unit.
3. Detach the wrist strap.
4. Replace the side access cover.

See Section 7.3 “Replacing the Side Access Cover” on page 7-5.
5. Connect any audio cables to the audio module.
6. Power on the system unit.

See Section 6.1 “Powering On the System Unit” on page 6-1.

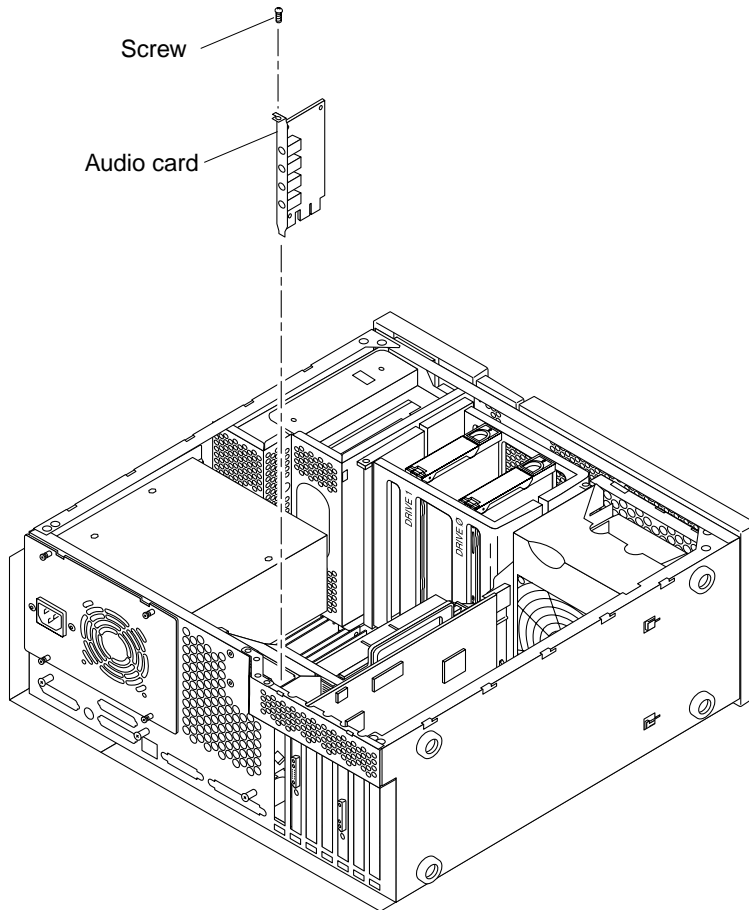

FIGURE 10-7 Removing and Replacing the Audio Card

10.7 Motherboard

To remove and replace the motherboard, proceed as follows.



Caution – Use an antistatic mat when working with the motherboard. An antistatic mat contains the cushioning needed to protect the underside components, to prevent motherboard flexing, and to provide antistatic protection.

Note – If the motherboard is being replaced, remove all DIMMs, UPA graphics cards, PCI card(s), audio card, and CPU module prior to removing the motherboard. Note the chassis slot location for each DIMM, UPA graphics card, and PCI card prior to removal.

Note – The NVRAM/TOD contains the system host identification (ID) and Ethernet address. If the same ID and Ethernet address are to be used on the replacement motherboard, remove the NVRAM/TOD from the motherboard and install the removed NVRAM/TOD on the replacement motherboard.

10.7.1 Removing the Motherboard

1. Power off the system unit.

See Section 6.2 “Powering Off the System Unit” on page 6-3.

2. Remove the side access cover.

See Section 7.1 “Removing the Side Access Cover” on page 7-1.

3. Attach a wrist strap.

See Section 7.2 “Attaching the Wrist Strap” on page 7-4.



Caution – Use proper ESD grounding techniques when handling components. Wear an antistatic wrist strap and use an ESD-protected mat. Store ESD-sensitive components in antistatic bags before placing them on any surface.

4. Remove the power supply.

See Section 8.1.1 “Removing the Power Supply” on page 8-2.

5. Remove the following from the motherboard:

a. PCI card(s).

See Section 10.3.1 “Removing a PCI Card” on page 10-6.

b. UPA graphics card(s).

See Section 10.4.1 “Removing a UPA Graphics Card” on page 10-9.

c. Audio card.

See Section 10.6.1 “Removing the Audio Card” on page 10-16.

d. NVRAM/TOD.

See Section 10.2.1 “Removing the NVRAM/TOD” on page 10-4.

Note – Do not remove the NVRAM/TOD if the one-piece shroud assembly is being removed.

6. Remove the motherboard as follows (FIGURE 10-8) and (FIGURE 10-9):

a. Unlatch the shroud from the PCI fan bracket hinge clip.

b. Disconnect the following:

- Peripheral cable. See Section 8.4.1 “Removing the Peripheral Power Cable Assembly” on page 8-10.

Note – Unconnected peripheral power cables should remain clipped inside the main chassis.

- External cables.
- DC power cable.
- Internal SCSI cable assembly.
- Speaker assembly cable connector.
- PCI fan assembly cable connector.

c. Using a number 2 Phillips screwdriver, proceed as follows:

- Remove the three screws securing the motherboard to the chassis.
- Loosen the two captive screws (until the screws pop up) securing either the one-piece or two-piece shroud assembly to the motherboard.

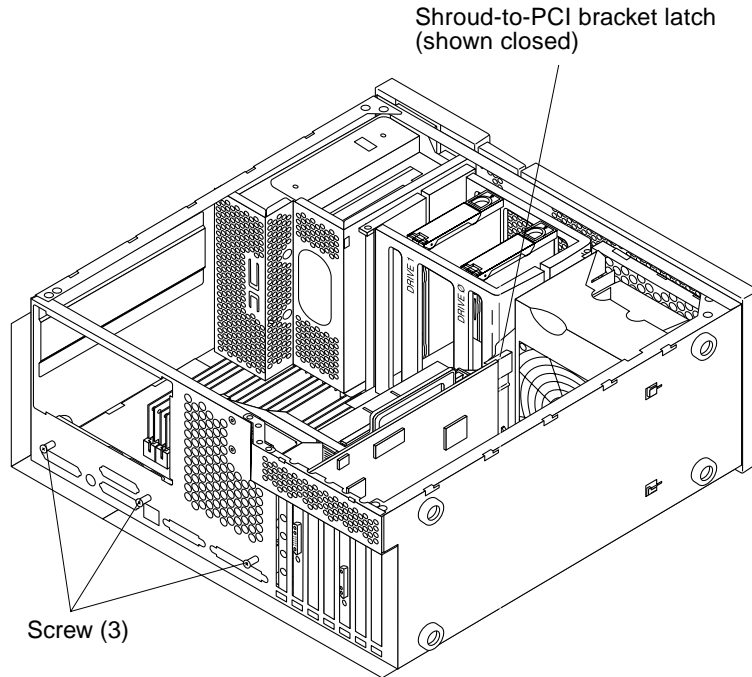

FIGURE 10-8 Removing and Replacing the Motherboard (Part 1 of 2)



Caution – Handle the motherboard by the handle, back panel, or the edges only.

- d. Grasping the shroud assembly handle, lift the motherboard from the chassis.
7. Place the motherboard on an antistatic mat.
 8. Remove the shroud assembly from the motherboard.
 - One-piece shroud assembly – See Section 8.9.1 “One-Piece Shroud Assembly” on page 8-25.
 - Two-piece shroud assembly – See Section 8.9.2 “Two-Piece Shroud Assembly” on page 8-28, beginning at Step 5.

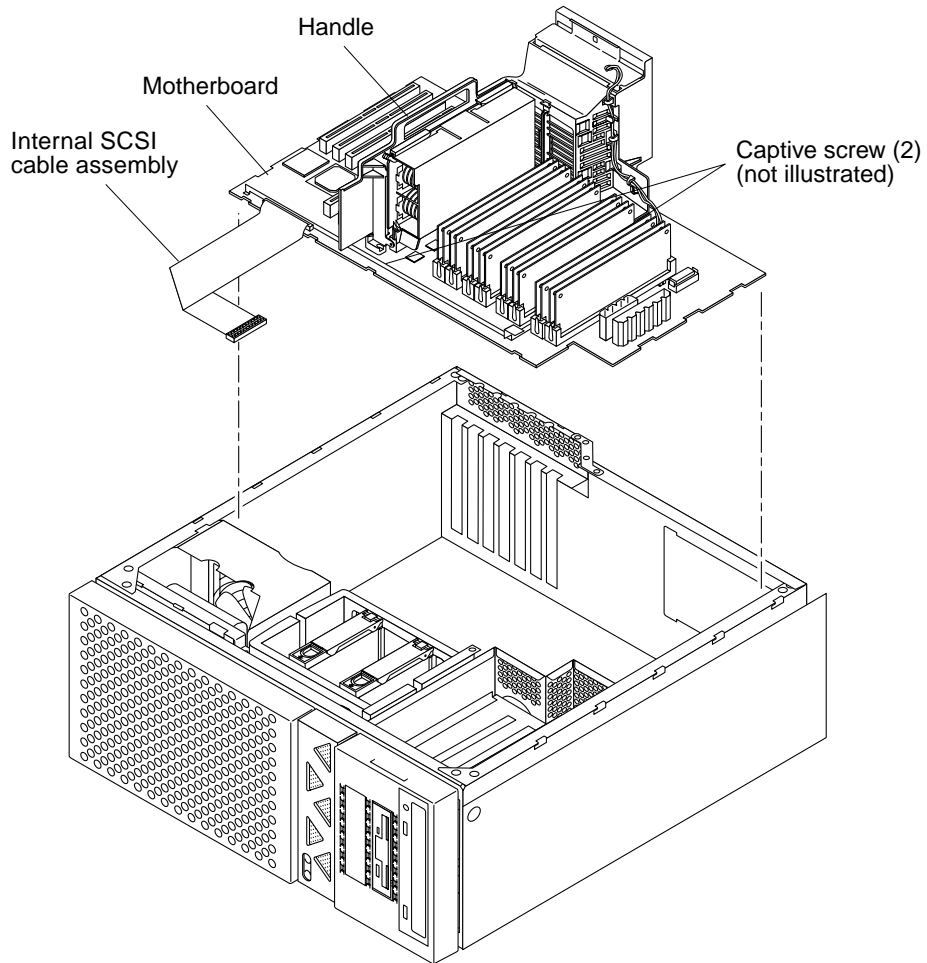

FIGURE 10-9 Removing and Replacing the Motherboard (Part 2 of 2)

10.7.2 Replacing the Motherboard



Caution – Use proper ESD grounding techniques when handling components. Wear an antistatic wrist strap and use an ESD-protected mat. Store ESD-sensitive components in antistatic bags before placing them on any surface.



Caution – Handle the motherboard by the handle, back panel, or the edges only.

Note – Jumpers J2604 and J2605 can be set to either RS-423 or RS-232 serial interface. The jumpers are preset for RS-423. RS-232 is required for digital telecommunication within the European Community.

1. Using needle-nose pliers, set the motherboard serial port jumpers J2604 and J2605.

See TABLE 10-2 and FIGURE 10-10.

TABLE 10-2 Motherboard Serial Port Jumpers J2604 and J2605

Jumper	Pins 1 + 2 Select	Pins 2 + 3 Select	Default Shunt on Pins
J2604	RS-232	RS-423	2 + 3
J2605	RS-232	RS-423	2 + 3



Caution – Handle the motherboard by the handle, back panel, or the edges only.

2. Place the motherboard on an antistatic mat.

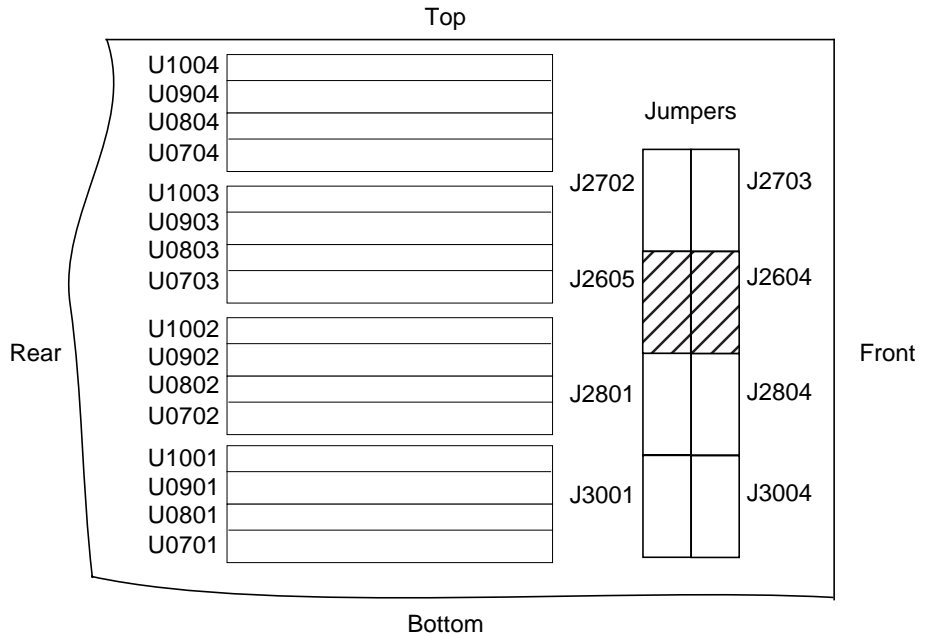

FIGURE 10-10 Location of the Motherboard Serial Port Jumpers

Note – Motherboard jumpers are identified with part numbers. Jumper pins are located immediately adjacent to the part number. Pin 1 is marked with an asterisk in any of the positions shown (FIGURE 10-11). Ensure that the serial port jumpers are set correctly.

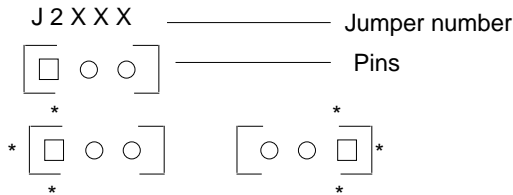

FIGURE 10-11 Identifying Jumper Pins

3. Replace the motherboard as follows:

a. Replace the shroud assembly to the motherboard.

- One-piece shroud assembly – See Section 8.9.1.2 “Replacing the One-Piece Shroud Assembly” on page 8-27.
- Two-piece shroud assembly – See Section 8.9.3.2 “Replacing the Two-Piece Shroud Fan Assembly” on page 8-32.

b. Grasp the shroud assembly handle and place the motherboard into the chassis (FIGURE 10-9).

c. Using a number 2 Phillips screwdriver, proceed as follows:

- i. Tighten the two captive screws securing the CPU fan assembly to the motherboard (FIGURE 10-9).
- ii. Tighten the three screws securing the motherboard to the chassis (FIGURE 10-8).

d. Connect the following:

- Speaker assembly cable connector.
- PCI fan assembly cable connector.
- Internal SCSI cable assembly.

Note – Ensure that the SCSI cable is routed through both plastic spring clips installed adjacent to the drive bay.

- DC power cable.
- External cables.

- Peripheral cable. See Section 8.4.2 “Replacing the Peripheral Power Cable Assembly” on page 8-11.

Note – Ensure that the peripheral power cable is routed through the cable routing clips.

- e. **Latch the shroud to the PCI fan bracket hinge clip.**
4. **Replace the following on the motherboard:**
 - a. **NVRAM/TOD.**

See Section 10.2.2 “Replacing the NVRAM/TOD” on page 10-5.
 - b. **UPA graphics card(s).**

See Section 10.4.2 “Replacing a UPA Graphics Card” on page 10-11.
 - c. **PCI card(s).**

See Section 10.3.2 “Replacing a PCI Card” on page 10-8.
 - d. **Audio card.**

See Section 10.6.2 “Replacing the Audio Card” on page 10-17.
5. **Replace the power supply.**

See Section 8.1.2 “Replacing the Power Supply” on page 8-4.
6. **Connect the AC power cord to the system unit.**
7. **Detach the wrist strap.**
8. **Replace the side access cover.**

See Section 7.3 “Replacing the Side Access Cover” on page 7-5.
9. **Reset the #power-cycles NVRAM variable to zero as follows:**
 - a. **Power on the system unit.**

See Section 6.1 “Powering On the System Unit” on page 6-1.
 - b. **Press the keyboard Stop and A keys after the system banner appears on the monitor.**
 - c. **At the ok prompt, type:**

```
ok setenv #power-cycles 0
```
 - d. **Verify the #power-cycles NVRAM variable increments each time the system is power cycled.**

Note – The Solaris operating environment Power Management software uses the `#power-cycles` NVRAM variable to control the frequency of automatic system shutdown if automatic shutdown is enabled.

Illustrated Parts List

This chapter lists the authorized replaceable parts for the Ultra 30 computer (system unit). FIGURE 11-1 illustrates an exploded view of the system unit. TABLE 11-1 lists the system unit replaceable components. A brief description of each listed component is also provided.

Note – Removal and replacement of selected system unit components are illustrated with photographs and audio/visual instructions on the *Ultra 30 ShowMe How Multimedia Documentation*, part number 704-5681.

Numerical references illustrated in FIGURE 11-1 correlate to the numerical references listed in TABLE 11-1. Consult your authorized Sun sales representative or service provider prior to ordering a replacement part.

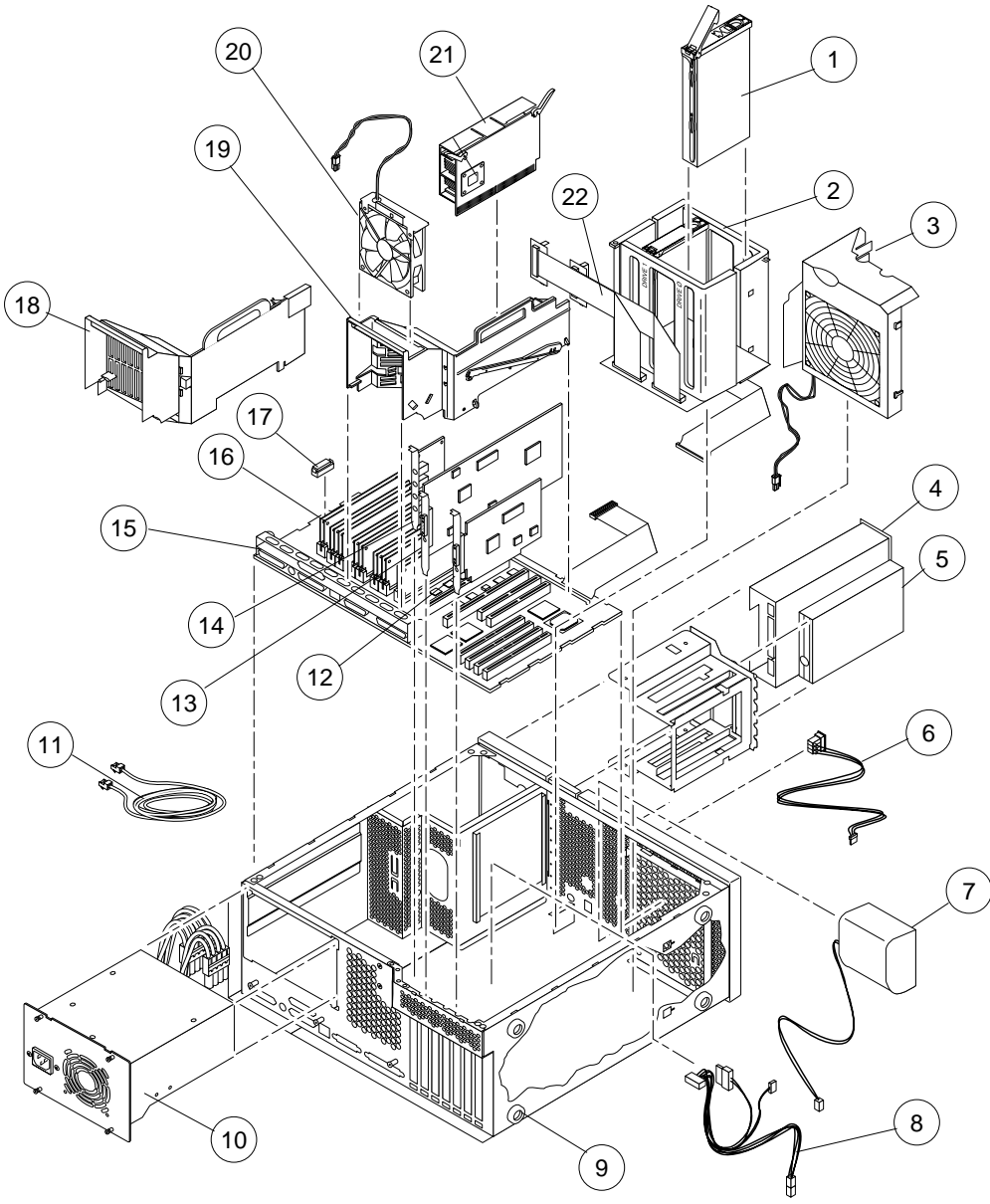

FIGURE 11-1 System Unit Exploded View**TABLE 11-1** System Unit Replaceable Components

Numerical Reference	Component	Description
1	2.1-Gbyte SCSI assembly	Hard drive
1	4.2-Gbyte SCSI assembly	Hard drive
1	9.1-Gbyte SCSI assembly	Hard drive
2	Hard drive bay with SCSI	Mechanical hard drive housing
3	PCI fan assembly	PCI fan
4	CD-ROM drive	CD-ROM drive
4	4-mm tape drive	12/24-Gbyte, 4-mm tape drive, DDS-3
4	8-mm tape drive	14-Gbyte, 8-mm tape drive
5	Manual eject floppy	Diskette drive
6	DC switch assembly	DC switch assembly
7	Speaker assembly	Speaker
8	Peripheral cable	Peripheral cable
9	Foot	Chassis foot
10	Power supply	Power supply
11	TPE cable (category 5)	Provides Ethernet interconnection
12	PCI card	Generic
13	Graphics card	Vertical, single buffer UPA graphics card, 75-MHz
13	Graphics card	Vertical, double buffer plus Z (DBZ) UPA graphics card, 75-MHz
13	Graphics card	Vertical, single buffer UPA graphics card, 83-MHz
13	Graphics card	Vertical, DBZ UPA graphics card, 83-Mhz
13	Graphics card	Vertical UPA graphics card, 100-MHz, without stereo application

TABLE 11-1 System Unit Replaceable Components *(Continued)*

Numerical Reference	Component	Description
13	Graphics card	Vertical UPA graphics card, 100-MHz, with stereo application
14	Audio module	Audio applications
15	Motherboard	System board
16	32-Mbyte DIMM	60-ns, 32-Mbyte DSIMM
16	64-Mbyte DIMM	60-ns, 64-Mbyte DSIMM
16	128-Mbyte DIMM	60-ns, 128-Mbyte DSIMM
17	NVRAM/TOD	Time of day, 48T59, with carrier
18	One-piece shroud assembly	CPU fan shroud
19	Two-piece shroud assembly	CPU fan shroud
20	Fan assembly	CPU fan
21	CPU module	250-MHz, 1-Mbyte external cache
21	CPU module	300-MHz, 2-Mbyte external cache
22	Diskette drive cable	Diskette drive cable
Not illustrated	Filler panel	Diskette drive filler panel
Not illustrated	Filler panel	CD-ROM drive or tape drive filler panel
Not illustrated	24-inch HDTV monitor	24-inch high-definition television monitor
Not illustrated	24-inch HDTV monitor	24-inch high-definition television monitor (logo-less)
Not illustrated	SCSI cable	68-pin external SCSI cable (2 m)
Not illustrated	SCSI cable	68-pin external SCSI cable (0.8-m)

Product Specifications

This appendix provides product specifications for the Ultra 30 computer.

- Section A.1 “Physical Specifications” on page A-1
- Section A.2 “Electrical Specifications” on page A-2
- Section A.3 “Environmental Requirements” on page A-2

A.1 Physical Specifications

TABLE A-1 lists physical specifications for the system unit.

TABLE A-1 Ultra 30 Physical Specifications

Specification	U.S.A.	Metric
Height	19.60 in.	49.80 cm
Width	17.70 in.	45.00 cm
Depth	7.50 in.	19.00 cm
Weight (approximate)	38.80 lb	17.60 kg

A.2 Electrical Specifications

TABLE A-2 lists electrical specifications for the system unit.

TABLE A-2 Ultra 30 Electrical Specifications

Parameter	Value
AC input	100 to 240 Vac, 47 to 63 Hz
DC output	Greater than or equal to 300W (total)
Output 1	+3.3 Vdc, 50A
Output 2	+5.0 Vdc, 30A
Output 3	+12.0 Vdc, 5.0A
Output 4	-12.0 Vdc, 0.4A
Output 5	-12.0V, 0.3A

A.3 Environmental Requirements

TABLE A-3 lists environmental requirements for the system unit.

TABLE A-3 Ultra 30 Environmental Requirements

Environmental	Operating	Non-operating
Temperature:	5 to 40° C ¹ (41 to 104° F)	-40 to 60° C (-40 to 140° F) ²
Temperature	4 to 95°F (5 to 35°C)	-4 to 140°F (-20 to 60°C)
Humidity	20 to 80% relative humidity (noncondensing) at 27° C (81° F) maximum wet bulb	93% relative humidity (noncondensing)
Altitude	10,000 ft (3 km)	40,000 ft (12 km)

1. Not to exceed 35° C (95° F) with tape media.

2. Refer to tape media specifications for recommended tape media storage.

Signal Descriptions

This appendix provides signal descriptions for the Ultra 30 computer (system unit) motherboard connectors. Tables B-1 through B-9 list connector pin assignments and signal descriptions. An illustration of each connector is also provided.

- Section B.1 “Keyboard/Mouse and Serial Ports A and B” on page B-1
- Section B.2 “Twisted-Pair Ethernet Connector” on page B-5
- Section B.3 “UltraSCSI Connector” on page B-6
- Section B.4 “Audio Connectors” on page B-10
- Section B.5 “Parallel Port Connector” on page B-11
- Section B.6 “Media Independent Interface Connector” on page B-13
- Section B.7 “UPA Graphics Card Connector” on page B-15

B.1 Keyboard/Mouse and Serial Ports A and B

B.1.1 Keyboard/Mouse Connector

The keyboard/mouse connector is a DIN-8 type connector located on the motherboard back panel. FIGURE B-1 illustrates the keyboard/mouse connector configuration and TABLE B-1 lists the connector pin assignments.

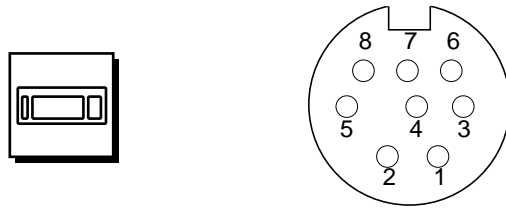

FIGURE B-1 Keyboard/Mouse Connector Pin Configuration

TABLE B-1 Keyboard/Mouse Connector Pin Assignments

Pin	Signal Name	Description
1	Gnd	Ground
2	Gnd	Ground
3	+5 Vdc	+5 Vdc
4	Mse-rxd	Mouse receive data
5	Kbd-txd	Keyboard out
6	Kbd-rxd	Keyboard in
7	Kbd-pwk	Keyboard power on
8	+5 Vdc	+5 Vdc

B.1.2 Serial Port A and B Connectors

The serial port A and B connectors are DB-25 type connectors located on the motherboard back panel. FIGURE B-2 illustrates the serial port A and serial port B connector configuration and TABLE B-2 lists the connector pin assignments.

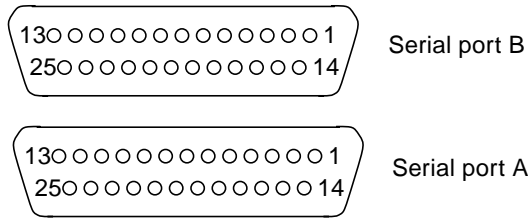

FIGURE B-2 Serial Port A and B Connector Pin Configurations

TABLE B-2 Serial Port A and B Connector Pin Assignments

Pin	Mnemonic	Signal Name	Description
1		Not connected	None
2	TXD	Transmit Data	Used by the data terminal equipment (DTE) to transmit data to the data circuit equipment (DCE). Except when control data is being sent, RTS, CTS, SYNC, and DCD must be ON for this line to be active.
3	RXD	Receive Data	Used by the DCE in response to received data from the DTE.
4	RTS	Ready To Send	Used by the DTE to condition the DCE for data transmission. The transition to ON directs the DCE to go into transmit mode. The transition to OFF directs the DCE to complete the transmission.
5	CTS	Clear To Send	Used by the DCE to indicate if it is ready to receive data from the DTE. When CTS, DSR, RTS, and DTR are ON, the DCE is ready to transmit data received from the DTE across the communications channel. When only CTS is ON, the DCE is ready to accept dialing or control signals only. When CTS is OFF, the DTE should not transfer data across TXD.

TABLE B-2 Serial Port A and B Connector Pin Assignments (*Continued*)

Pin	Mnemonic	Signal Name	Description
6	DSR	Data Set Ready	Used by the DCE to indicate if it is ready to operate. When DSR is ON, the DCE is connected to the line and ready to exchange further control signals to start data transfer.
7	Gnd	Signal Ground	
8	DCD	Data Carrier Detect	Used by the DCE to indicate it is receiving a suitable signal from the communications channel.
9		Not connected	None.
10		Not connected	None.
11		Not connected	None.
12		Not connected	None.
13		Not connected	None.
14		Not connected	None.
15	TRXC	Transmit Clock	Used by the DCE to provide timing information to the DTE. The DTE provides data on TXD in which the transition of the bit corresponds to the rising edge of the clock.
16		Not connected	None.
17	RTXC	Receive Clock	Used by the DCE to provide timing information to the DTE. The falling edge of the clock corresponds to the center of the data bit received on RXD.
18		Not connected	None.
19		Not connected	None.
20	DTR	Data Terminal Ready	Used to control switching of the DCE to the communication channel. Once disabled, DTR can not be enabled until SYNC is turned OFF.
21		Not connected	None.

TABLE B-2 Serial Port A and B Connector Pin Assignments (*Continued*)

Pin	Mnemonic	Signal Name	Description
22		Not connected	None.
23		Not connected	None.
24	TXC	Terminal Clock	Generated by the DTE to provide timing information to the DCE. Used only in synchronous mode and only when the driver requests a locally generated clock. Otherwise, TXC echoes the modem-generated clock. The falling edge of the clock corresponds to the center of the data bit transmitted on TXD.
25		Not connected	None.

B.2 Twisted-Pair Ethernet Connector

The twisted-pair Ethernet (TPE) connector is an RJ-45 type connector located on the motherboard board back panel. FIGURE B-3 illustrates the TPE connector configuration and TABLE B-3 lists the connector pin assignments.



Caution – Connect only TPE cable into the TPE connector.

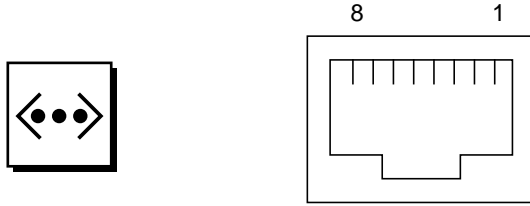

FIGURE B-3 TPE Connector Pin Configuration

TABLE B-3 TPE Connector Pin Assignments

Pin	Signal Name	Description
1	tpe0	Transmit data +
2	tpe1	Transmit data -
3	tpe2	Receive data +
4	Common mode termination	Termination
5	Common mode termination	Termination
6	tpe3	Receive data -
7	Common mode termination	Termination
8	Common mode termination	Termination

B.3 UltraSCSI Connector

The UltraSCSI connector is located on the motherboard back panel. FIGURE B-4 illustrates the UltraSCSI connector configuration and TABLE B-4 lists the connector pin assignments.

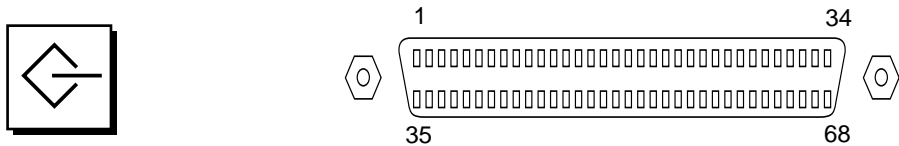

FIGURE B-4 UltraSCSI Connector Pin Configuration

TABLE B-4 UltraSCSI Connector Pin Assignments

Pin	Signal Name	Description
1	Gnd	Ground
2	Gnd	Ground
3	Gnd	Ground
4	Gnd	Ground
5	Gnd	Ground
6	Gnd	Ground
7	Gnd	Ground
8	Gnd	Ground
9	Gnd	Ground
10	Gnd	Ground
11	Gnd	Ground
12	Gnd	Ground
13	Gnd	Ground
14	Gnd	Ground
15	Gnd	Ground
16	Gnd	Ground

TABLE B-4 UltraSCSI Connector Pin Assignments *(Continued)*

Pin	Signal Name	Description
17	Termpower	Termpower
18	Termpower	Termpower
19	Not used	Undefined
20	Gnd	Ground
21	Gnd	Ground
22	Gnd	Ground
23	Gnd	Ground
24	Gnd	Ground
25	Gnd	Ground
26	Gnd	Ground
27	Gnd	Ground
28	Gnd	Ground
29	Gnd	Ground
30	Gnd	Ground
31	Gnd	Ground
32	Gnd	Ground
33	Gnd	Ground
34	Gnd	Ground
35	Dat<12>_	Data 12
36	Dat<13>_	Data 13
37	Dat<14>_	Data 14
38	Dat<15>_	Data 15
39	Par1 l_	Parity 1

TABLE B-4 UltraSCSI Connector Pin Assignments *(Continued)*

Pin	Signal Name	Description
40	Dat<0>_	Data 0
41	Dat<1>_	Data 1
42	Dat<2>_	Data 2
43	Dat<3>_	Data 3
44	Dat<4>_	Data 4
45	Dat<5>_	Data 5
46	Dat<6>_	Data 6
47	Dat<7>_	Data 7
48	Par0 l_	Parity 0
49	Gnd	Ground
50	Term_dis_	Term disable
51	Termpower	Termpower
52	Termpower	Termpower
53	Not used	Undefined
54	Gnd	Ground
55	Atn_	Attention
56	Gnd	Ground
57	Bsy_	Busy
58	Ack_	Acknowledge
59	Rst_	Reset
60	Msg_	Message
61	Sel_	Select
62	Cd_	Command

TABLE B-4 UltraSCSI Connector Pin Assignments (Continued)

Pin	Signal Name	Description
63	Req_	Request
64	IO_	In/Out
65	Dat<8>_	Data 8
66	Dat<9>_	Data 9
67	Dat<10>_	Data 10
68	Dat<11>_	Data 11

B.4 Audio Connectors

The audio connectors are located on the audio card. These connectors use EIA standard 3.5-mm/0.125-inch jacks. FIGURE B-5 illustrates each audio connector configuration and TABLE B-5 lists each connector line assignment.

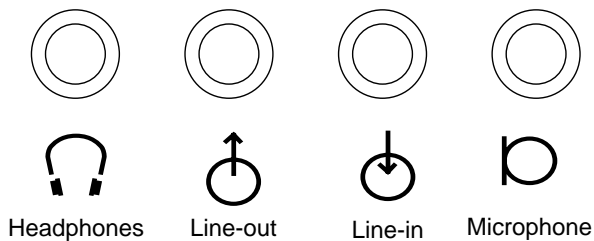

FIGURE B-5 Audio Connector Configuration

TABLE B-5 Audio Connector Line Assignments

Component	Headphones	Line Out	Line In	Microphone
Tip	Left channel	Left channel	Left channel	Left channel
Ring (center)	Right channel	Right channel	Right channel	Right channel
Shield	Ground	Ground	Ground	Ground

B.5 Parallel Port Connector

The parallel port connector is a DB-25 type connector located on the motherboard back panel. FIGURE B-6 illustrates the parallel port connector configuration and TABLE B-6 lists the connector pin assignments.

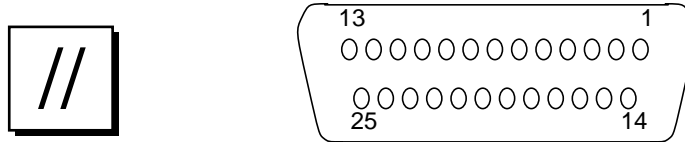

FIGURE B-6 Parallel Port Connector Pin Configuration

TABLE B-6 Parallel Port Connector Pin Assignments

Pin	Mnemonic	Signal Name	Description
1	Data_Strobe_L	Data Strobe Low	Set low during forward channel transfers to latch data into peripheral device. Set high during reverse channel transfers.
2 to 9	Data[0..7]	Data0 Thru Data7	The main data bus for the parallel port. Data0 is the least significant bit (LSB). Are not used during reverse channel transfers.
10	ACK_L	Acknowledge Low	Driven low by the peripheral device to acknowledge data byte transfer from host during forward channel transfer. Qualifies data being transferred to host in reverse channel transfer.
11	BUSY	Busy	Driven high to indicate the peripheral device is not ready to receive data during forward channel transfer. Used to send Data3 and Data7 during reverse channel transfer.

TABLE B-6 Parallel Port Connector Pin Assignments (*Continued*)

Pin	Mnemonic	Signal Name	Description
12	PERROR	Parity Error	Driven high by peripheral device to indicate an error in the paper path during forward channel transfer. Used to send Data2 and Data6 during reverse channel transfer.
13	SELECT_L	Select Low	Indicates the peripheral device is on line during forward channel transfer. Used to send Data1 and Data5 during reverse channel transfer.
14	AFXN_L	Auto Feed Low	Set low by the host to drive the peripheral into auto-line feed mode during forward channel transfer. During reverse channel transfer, set low to indicate host can receive peripheral device data and then set high to acknowledge receipt of peripheral data.
15	ERROR_L	Error Low	Set low by the peripheral device to indicate an error during forward channel transfer. In reverse channel transfer, set low to indicate peripheral device has data ready to send to the host. Used to send Data0 and Data4.
16	INIT_L	Initialize Low	Driven low by the host to reset peripheral.
17	PAR_IN_L	Peripheral Input Low	Set low by the host to select peripheral device for forward channel transfer. Set high to indicate bus direction is from peripheral to host.
18		Signal Ground	Signal ground.
19		Signal Ground	Signal ground.
20		Signal Ground	Signal ground.
21		Signal Ground	Signal ground.
22		Signal Ground	Signal ground.

TABLE B-6 Parallel Port Connector Pin Assignments (*Continued*)

Pin	Mnemonic	Signal Name	Description
23		Signal ground	Signal ground
24		Signal ground	Signal ground
25		Signal ground	Signal ground

B.6 Media Independent Interface Connector

The media independent interface (MII) connector is located on the motherboard back panel. FIGURE B-7 illustrates the MII connector configuration and TABLE B-7 lists the connector pin assignments.

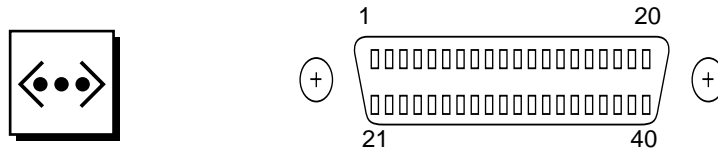

FIGURE B-7 MII Connector Pin Configuration

TABLE B-7 MII Connector Pin Assignments

Pin	Signal Name	Description
1	Pwr	Power
2	Mdio	Management data I/O
3	Mdc	Management data clock
4	Rxd3	Receive data 3
5	Rxd2	Receive data 2
6	Rxd1	Receive data 1

TABLE B-7 MII Connector Pin Assignments *(Continued)*

Pin	Signal Name	Description
7	Rxd0	Receive data 0
8	Rx dv	Receive data valid
9	Rx clk	Receive clock
10	Rx er	Receive error
11	Tx er	Transmit error
12	Tx clk	Transmit clock
13	Tx en	Transmit data enable
14	Txd0	Transmit data 0
15	Txd1	Transmit data 1
16	Txd2	Transmit data 2
17	Txd3	Transmit data 3
18	Col	Collision detected
19	Crs	Carrier sense
20	Pwr	Power
21	Pwr	Power
22	Gnd	Ground
23	Gnd	Ground
24	Gnd	Ground
25	Gnd	Ground
26	Gnd	Ground
27	Gnd	Ground
28	Gnd	Ground
29	Gnd	Ground

TABLE B-7 MII Connector Pin Assignments (*Continued*)

Pin	Signal Name	Description
30	Gnd	Ground
31	Gnd	Ground
32	Gnd	Ground
33	Gnd	Ground
34	Gnd	Ground
35	Gnd	Ground
36	Gnd	Ground
37	Gnd	Ground
38	Gnd	Ground
39	Gnd	Ground
40	Pwr	Power

B.7 UPA Graphics Card Connector

The UPA graphics card connector is located on the UPA graphics card. FIGURE B-8 illustrates the UPA graphics card connector configuration and TABLE B-8 lists the connector pin assignments.

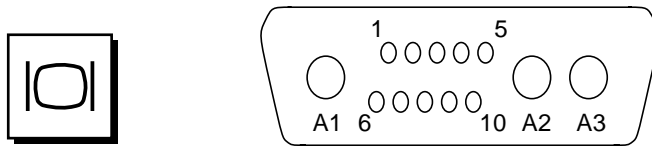

FIGURE B-8 UPA Graphics Card Con

TABLE B-8 UPA Graphics Card Connector Pin Assignments

Pin	Signal Name	Description
A1	R	Red
A2	G	Green
A3	B	Blue
1	Serial Read	Serial Read
2	Vert Sync	Vertical Sync
3	Sense <0>	Sense <0>
4	Gnd	Ground
5	Comp Sync	Composite Sync
6	Horiz Sync	Horizontal Sync
7	Serial Write	Serial Write
8	Sense <1>	Sense <1>
9	Sense <2>	Sense <2>
10	Gnd	Ground

Functional Description

This appendix provides a functional description for the Ultra 30 computer (system unit).

- Section C.1 “System Unit” on page C-1
- Section C.2 “Motherboard” on page C-41
- Section C.3 “Jumper Descriptions” on page C-43
- Section C.4 “Enclosure” on page C-45
- Section C.5 “Environmental Compliance” on page C-46
- Section C.6 “Agency Compliance” on page C-46

C.1 System Unit

The system unit is an UltraSPARC port architecture (UPA)-based uniprocessor machine that uses peripheral component interconnect (PCI) as the I/O bus. The CPU module, U2P ASIC (UPA-to-PCI bridge), and UPA graphics cards communicate with each other using the UPA protocol. The CPU module and the U2P ASIC are UPA master-slave devices. The UPA graphics cards are UPA slave-only devices. The SC_UP+ ASIC routes UPA requests packets through the UPA address bus and controls the flow of data using the UltraBMX ASIC. FIGURE C-1 illustrates the functional throughput of the various ASICs and buses.

- Section C.1.1 “UPA” on page C-4
- Section C.1.2 “PCI Bus” on page C-5
- Section C.1.3 “UltraSPARC II Processor” on page C-6
- Section C.1.4 “Memory System” on page C-7
- Section C.1.5 “Peripherals” on page C-14
- Section C.1.6 “Keyboard and Mouse, Diskette, and Parallel Port” on page C-19
- Section C.1.7 “Serial Port” on page C-21
- Section C.1.8 “Ethernet” on page C-24

- Section C.1.9 “Audio Card and Connector” on page C-27
- Section C.1.10 “SCSI” on page C-28
- Section C.1.11 “ASIC” on page C-32
- Section C.1.12 “SuperIO” on page C-34
- Section C.1.13 “Power Supply” on page C-35
- Section C.1.14 “Control Signals” on page C-36
- Section C.1.15 “Built-In Speaker” on page C-40
- Section C.1.16 “Microphone” on page C-41
- Section C.1.17 “Standard System Facilities” on page C-41

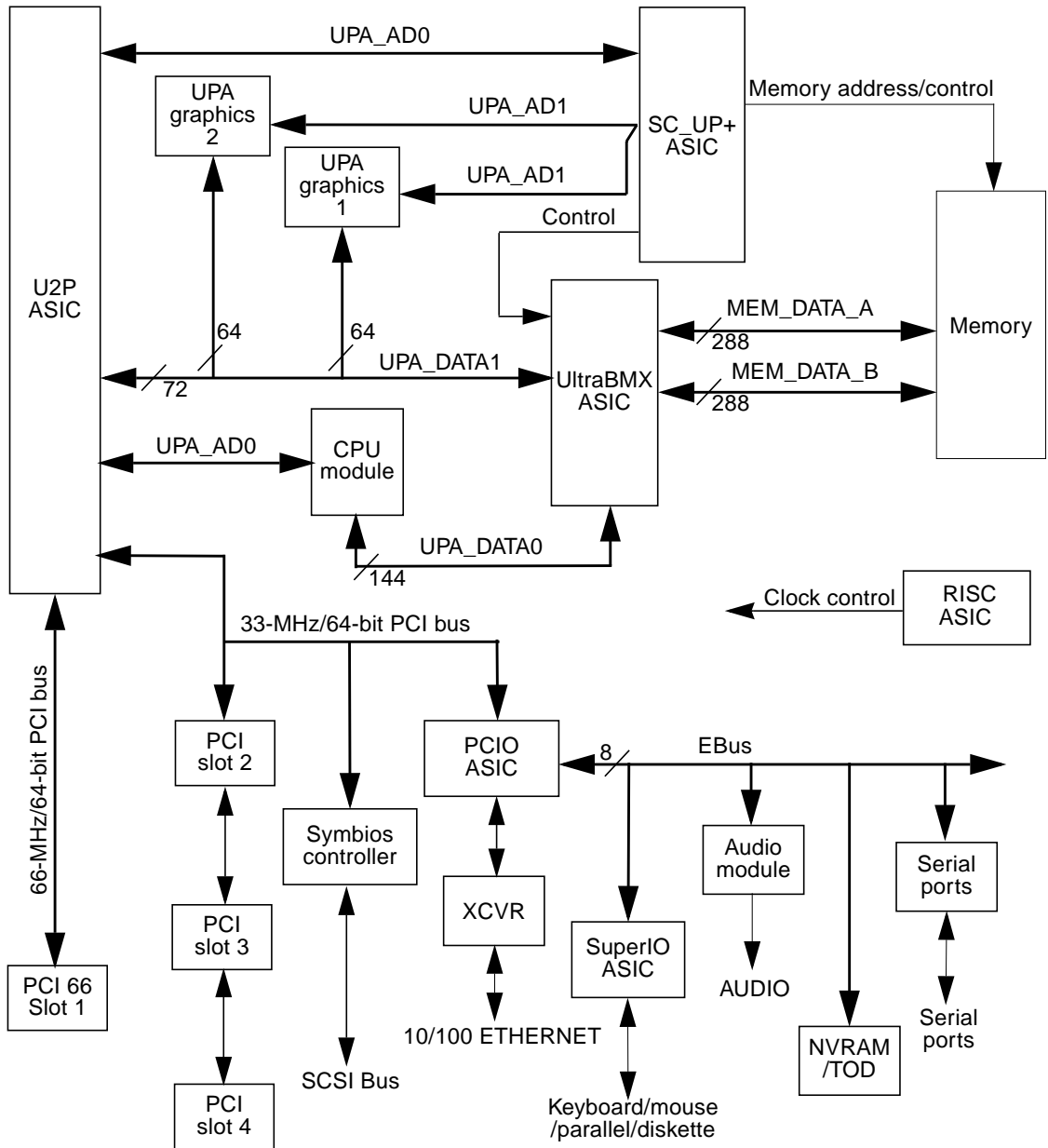

FIGURE C-1 System Unit Functional Block Diagram

C.1.1 UPA

The UltraSPARC port architecture (UPA) provides a packet-based interconnect between the UPA clients: CPU module, U2P ASIC, UPA graphics 0, and UPA graphics 1. Electrical interconnection is provided through two address buses and two data buses. See FIGURE C-2.

The two address buses are:

- UPA address bus 0 (UPA_AD0)
- UPA address bus 1 (UPA_AD1)

The two data buses are:

- UPA data bus 0 (UPA_DATA0)
- UPA data bus 1 (UPA_DATA1).

UPA_AD0 connects the SC_UP+ ASIC to the CPU module and the U2P ASIC. UPA_AD1 connects the SC_UP+ ASIC to UPA graphics 0 and UPA graphics 1. UPA_DATA0 is a bidirectional 144-bit data bus (128 bits of data and 16 bits of ECC) that connects the CPU module to the UltraBMX ASIC. UPA_DATA1 is a bidirectional 72-bit data bus (64 bits of data and eight bits of ECC) that connects the U2P ASIC and the UPA graphics to the UltraBMX ASIC. The UPA graphics do not have ECC, and therefore only consist of 64 bits of data.

TABLE C-1 lists UPA port identification assignments. FIGURE C-2 illustrates how the UPA address and data buses are connected between the UPA and the UPA clients.

TABLE C-1 UPA Port Identification Assignments

UPA Slot Number	UPA Port ID <4:0>
CPU module slot 0	0x0
U2P ASIC	0x1F

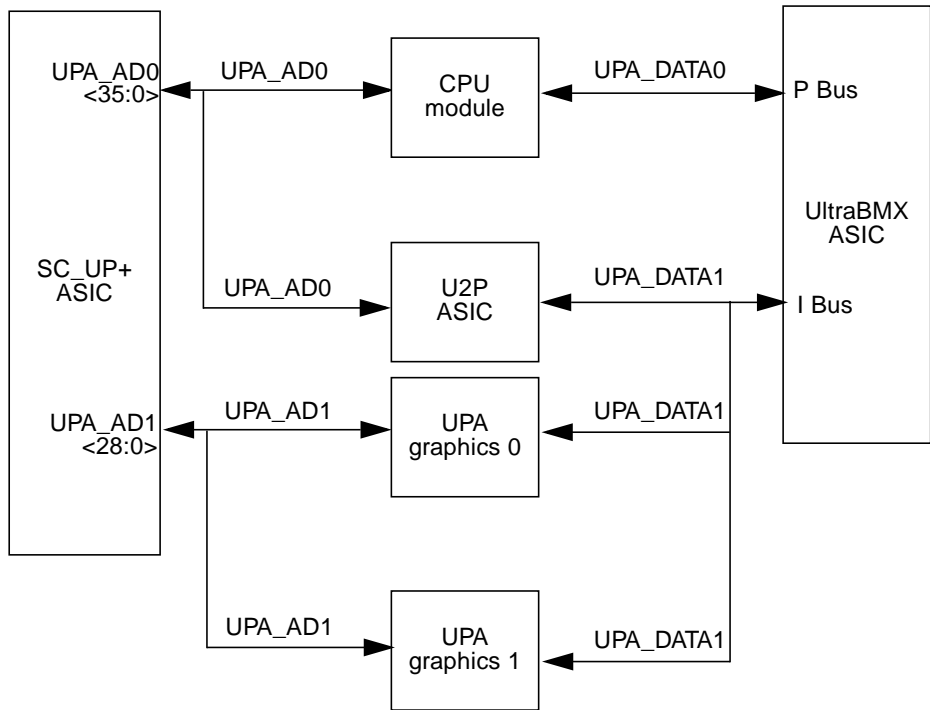

FIGURE C-2 UPA Address and Data Buses Functional Block Diagram

C.1.2 PCI Bus

The peripheral component interconnect (PCI) bus is a high-performance 32-bit or 64-bit bus with multiplexed address and data lines. The PCI bus provides electrical interconnect between highly integrated peripheral controller components, peripheral add-on devices, and the processor/memory system.

There are two PCI buses (FIGURE C-1). The first bus is a one-slot, 3.3-Vdc, 64-bit or 32-bit, 66-MHz or 32-MHz bus. The second bus is a three-slot, 5.0-Vdc, 64-bit or 32-bit, 33-MHz bus. Each bus is controlled by the UPA-to-PCI bridge (U2P) ASIC. There are also two on-board controllers, the Symbios 53C875 SCSI controller and the PCI-to-EBus/Ethernet controller (PCIO) ASIC, on the 33-MHz PCI bus.

C.1.2.1 U2P ASIC

The UPA-to-PCI bridge (U2P) ASIC controls the PCI buses. It forms the bridge from the UPA bus to the PCI buses. For a brief description of the U2P ASIC, see Section C.1.11.4 “U2P” on page C-33.

C.1.2.2 Symbios 53C875 SCSI Controller

The Symbios 53C875 SCSI controller provides electrical connection between the motherboard and the internal and external SCSI buses to the PCI bus. The Symbios controller also provides the SCSI bus control.

C.1.2.3 PCIO ASIC

The PCI-to-EBus/Ethernet controller (PCIO) ASIC bridges the PCI bus to the EBus, enabling communication between the PCI bus and all miscellaneous I/O functions, as well as the connection to slower on-board functions. The PCIO ASIC also embeds the Ethernet controller. For a brief description of the PCIO ASIC, see Section C.1.2.3 “PCIO ASIC” on page C-6.

C.1.3 UltraSPARC II Processor

The UltraSPARC II processor is a high-performance, highly-integrated superscalar processor implementing the SPARC-V9 64-bit RISC architecture. The UltraSPARC II processor is capable of sustaining the execution of up to four instructions per cycle even in the presence of conditional branches and cache misses. This sustained performance is supported by a decoupled prefetch and dispatch unit with instruction buffer. The UltraSPARC II processor supports both 2D and 3D graphics, as well as image processing, video compression and decompression, and video effects through the sophisticated visual instruction set (VIS). VIS provides high levels of multimedia performance, including real-time video compression/decompression and two streams of MPEG-2 decompression at full broadcast quality with no additional hardware support. The UltraSPARC II processor provides either a 1-Mbyte or 2-Mbyte ecache, with system operating frequencies from 250 MHz to 300 MHz.

UltraSPARC II processor characteristics and associated features include:

- SPARC-V9 architecture compliant
- Binary compatible with all SPARC application code
- Multimedia capable visual instruction set (VIS)
 - Multi-processing support
 - Glueless four-processor connection with minimum latency
- Snooping or directory based protocol support
- Four-way superscalar design with nine execution units and four integer execution units
- Three floating-point execution units
- Two graphics execution units
- Selectable little- or big-endian byte ordering

- 64-bit address pointers
- 16-Kbyte non-blocking data cache
- 16-Kbyte instruction cache with single cycle branch following
- Power management
- Software prefetch instruction support
- Multiple outstanding requests

C.1.4 Memory System

The memory system (FIGURE C-3) consists of three components: the system controller uniprocessor plus (SC_UP+) ASIC, the crossbar switch 1 (UltraBMX) ASIC, and the memory module. The SC_UP+ ASIC generates memory addresses and control signals to the memory module. The SC_UP+ ASIC also coordinates the data transfers among the DIMMs through the 144-bit-wide processor data bus (UPA_DATA0) and the 72-bit-wide I/O data bus (UPA_DATA1).

DIMMs are organized in four rows with each row consisting of a bank 0 and a bank 1. DIMM capacities of 16 Mbytes, 32 Mbytes, 64 Mbytes, and 128 Mbytes are supported by the memory module. When all DIMM slots are populated (16 DIMMs) with 128-Mbyte DIMMs, maximum memory capacity is 2 gigabytes.

Organizing two DIMM banks of a given row with 128-Mbyte (plus ECC bit) DIMMs allows data streams to be transferred on two 288-bit-wide (plus ECC) memory data bus, designated MEM_DAT_A and MEM_DAT_B. The UltraBMX ASIC is controlled by the SC_UP+ ASIC and performs all data bus switching.

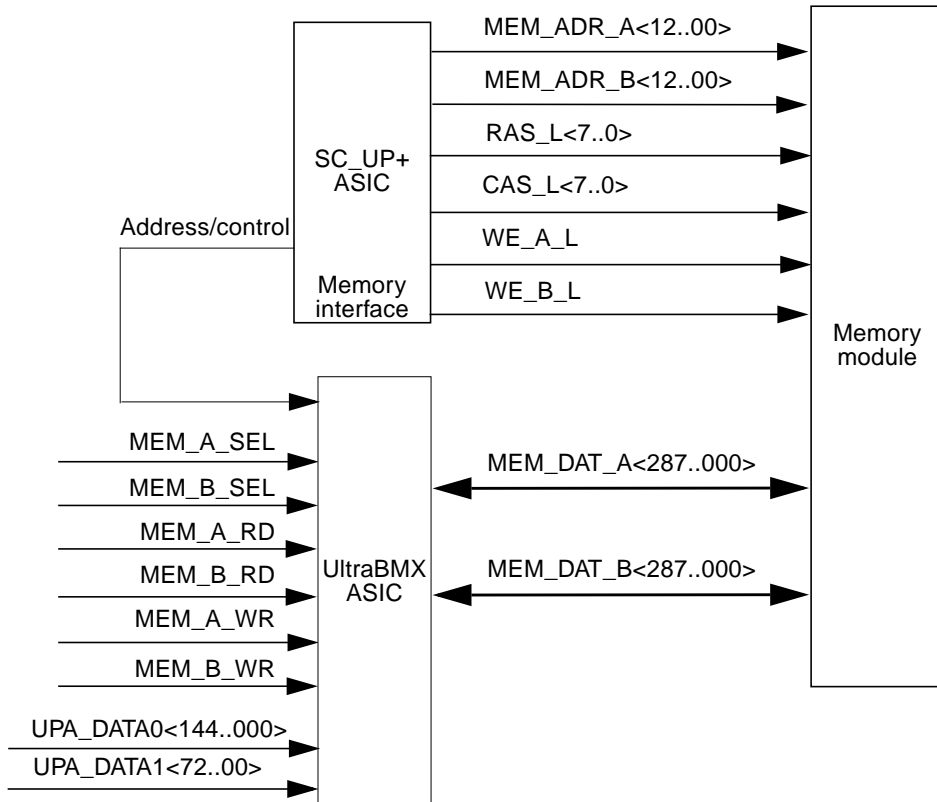

FIGURE C-3 Memory System Functional Block Diagram

As shown in FIGURE C-4 and FIGURE C-5, the memory module is arranged in two banks. DIMMs are always accessed in pairs. Consequently, the memory system must be installed in pairs and individual DIMMs within a pair should be of equal capacity. FIGURE C-6 illustrates DIMM row mapping.



Caution – Failure to populate a DIMM pair with DIMMs of equal capacity and at least 60-ns speed will result in inefficient use of memory resource or system failure.

Note – For best system performance, install four DIMMs of identical capacity.

The memory system normally operates in a non-interleave mode. To operate in the interleave mode, three conditions must exist:

- The interleave bit in the SC_UP+ ASIC is set.
- Any row containing DIMMs is fully populated.

- All DIMMs in the same row must have identical capacity.

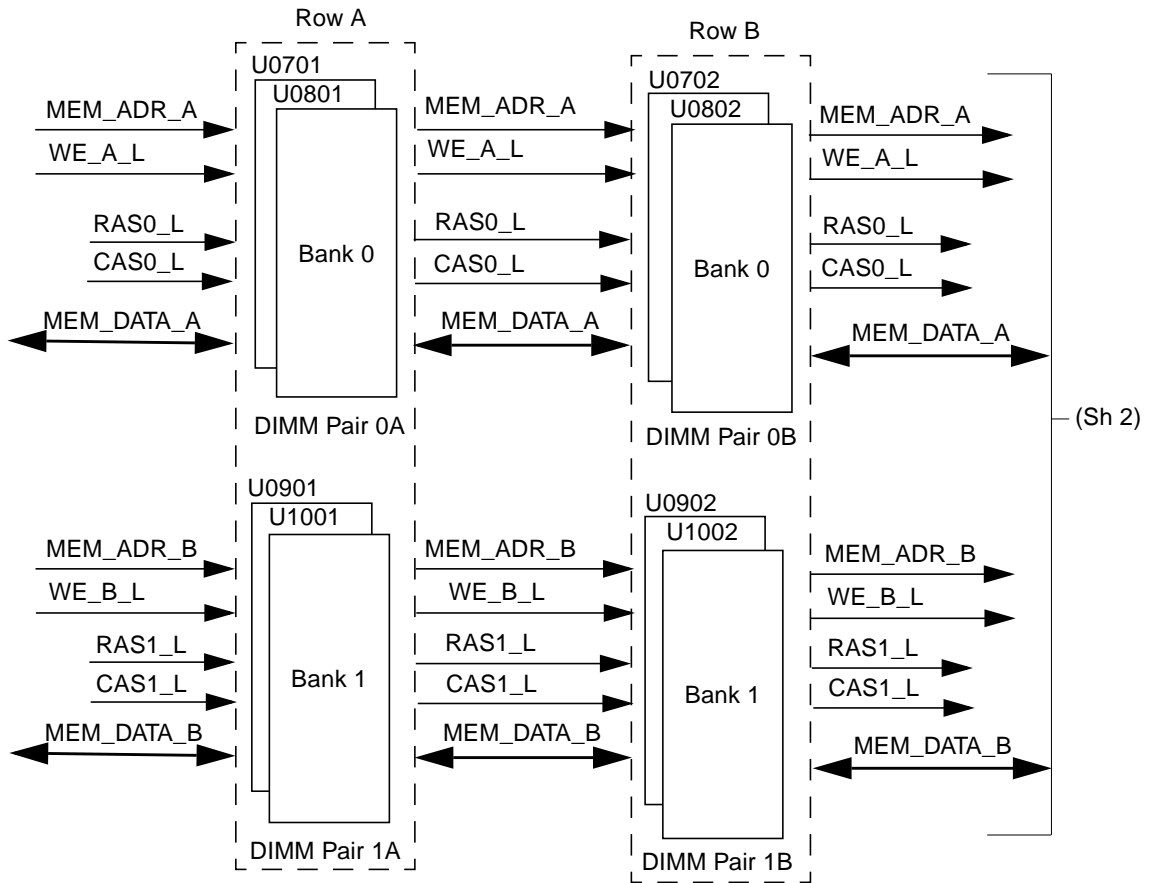

FIGURE C-4 Memory Module Functional Block Diagram (Part 1 of 2)

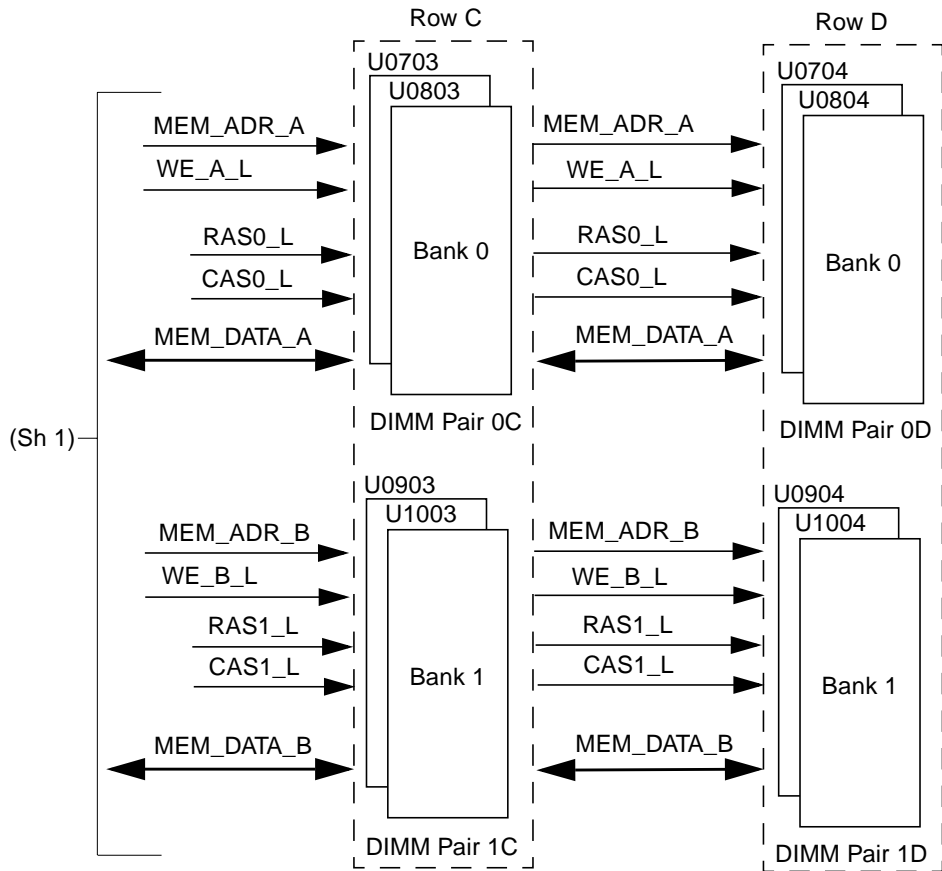

FIGURE C-5 Memory Module Functional Block Diagram (Part 2 of 2)

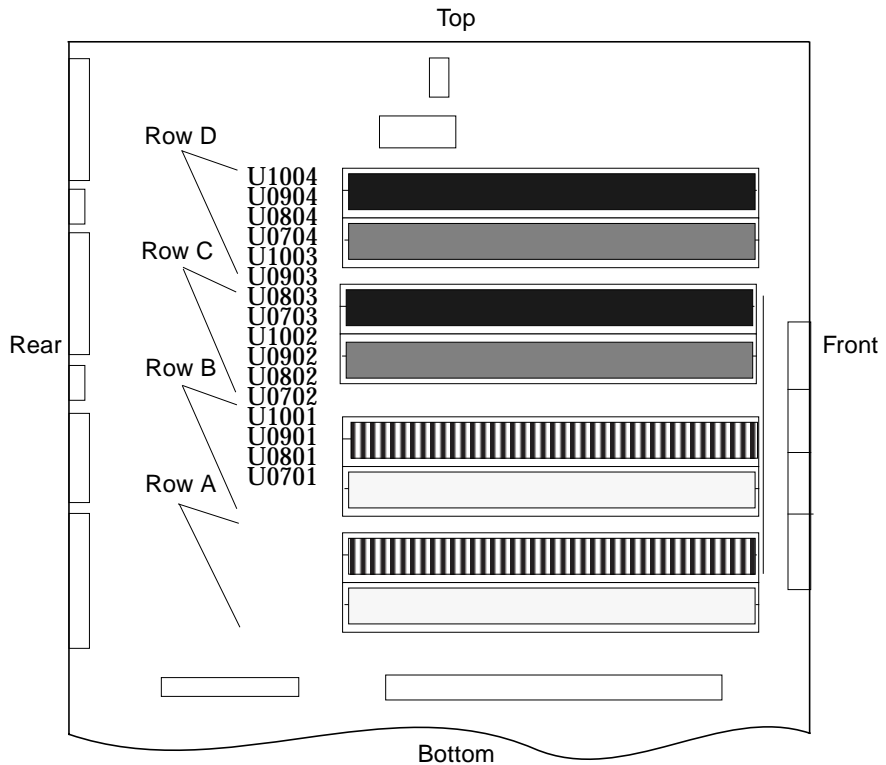

FIGURE C-6 DIMM Row Mapping

C.1.4.1 DIMM

The DIMM is a 60-nanosecond, fast-page-mode-style DIMM. Four DIMM configurations are supported in the system unit: 16-Mbyte, 32-Mbyte, 64-Mbyte, and 128-Mbyte. The minimum memory capacity is 32 Mbytes (two 16-Mbyte DIMMs). The maximum memory capacity is 2 Gbytes (sixteen 128-Mbyte DIMMs).

A block of data (64 bytes) always comes from one pair of DIMMs, even in interleaved mode. An error code containing the address of where a failure occurred, as well as the associated syndrome, is logged when an ECC error occurs.

There are a total of eight DIMM-pairs in the system unit. TABLE C-2 matches DIMM pairs to U numbers. TABLE C-3 lists non-interleave (IL = 0) physical address mapping to DIMM pairs. TABLE C-4 lists interleave (IL = 1) physical address maps to DIMM pairs. The DIMM pair numbering scheme is illustrated in FIGURE C-4.

TABLE C-2 DIMM Pair-To-U Number

DIMM Pair	U Number
0A	U0701 and U0801
0B	U0702 and U0802
0C	U0703 and U0803
0D	U0704 and U0804
1A	U0901 and U1001
1B	U0902 and U1002
1C	U0903 and U1003
1D	U0904 and U1004

TABLE C-3 Physical Address Map to DIMM Pair (Non-Interleave)

DIMM Pair	PA[30:28]
0A	000
0B	001
1A	010
1B	011
2A	100
2B	101
3A	110
3B	111

TABLE C-4 Physical Address Maps to DIMM Pair (Interleave)

DIMM Pair	{PA[30:29],PA[6]}
0A	000
0B	001
1A	010
1B	011
2A	100
2B	101
3A	110
3B	111

C.1.4.2 Memory System Timing

The SC_UP+ ASIC generates the memory addresses and control signals to the memory system. The UPA clock is the clock source for the SC_UP+ ASIC and operates at a 100-MHz frequency.

The system unit takes advantage of UPA features to provide high-performance graphics. High-performance graphics can include a vertical, single buffer UPA graphics card or a vertical, double buffer plus Z (DBZ) UPA graphics card. The UPA graphics card consists of the frame buffer controller (FBC) ASIC, the three-dimensional RAM (3DRAM), the RAM digital-to-analog converter (RAMDAC), and associated circuitry. The graphics card connects to the system unit through the UPA64S expansion connector.

The 3DRAM is a standard dynamic random-access memory (DRAM) that includes a multi-level cache and a separate graphics port. The FBC ASIC provides acceleration for 2-D and 3-D imaging primitives. This, combined with the 3DRAM cache and support for graphics operations, supports a high-performance frame buffer.

C.1.4.3 Graphics Card Features

Features provided by the UPA graphics card include:

- YCC-to-RGB color space conversion for faster video decompression
- Contrast stretch support for imaging
- Line doubling for interlaced video writes
- Consecutive block prefetch for smart frame buffer reads
- DDC2B monitor serial communication with EDID default resolution support in the boot PROM

- 3DRAM3 OpenGL stencil function (four planes) support
- New RAMDAC support
- Single-buffered high-resolution (2.5 Mpixels) supports the following screen resolutions (DBZ graphics card only):
 - 1920 × 1360 landscape mode (HDTV)
 - 1280 × 2048 portrait mode (medical)
- Buffer B addressing for stateless (dumb frame buffer) and video accesses
- Simultaneous 8-bit and 24-bit visual support
- Multiple hardware color maps
- Programmable gamma correction; four color lookup tables help eliminate color flashing within 8-bit window system environment
- Texture cache for texture mapping
- Acceleration for X11 and XIL graphics libraries
- Acceleration for 3-D applications (XGL, OpenGL, and Java3D)
- 3-D solids, dynamic shading, rotation, and Z-buffered acceleration
- High resolution (1280 x 1024 at 76 Hz, non-interlaced)
- Stereo ready (960 x 680 at 122 Hz, non-interlaced)
- Dedicated graphics floating-point processing (can turn on more light points for enhanced visual display without a performance penalty)

C.1.4.4 Graphics Card Performance

The UPA graphics cards have identical window system performance characteristics, 2-D graphics, and imaging and video applications. In addition, the UPA graphics cards provide very fast, high-quality transformation and display of 3-D solid and wireframe objects and dramatically accelerates high-end functionality like double buffering, triangle and quad rendering, and lighting and shading. At the same time, the UPA graphics cards accelerate 2-D objects that meet X11 rules. Fast 8- and 24-bit window system and imaging performance are provided along with acceleration for decompression and display of compressed digital video.

C.1.5 Peripherals

The following peripherals are supported by the system unit: CD-ROM drive, diskette drive, and hard drive. An optional 4-mm or 8-mm tape drive is also supported.

C.1.5.1 CD-ROM Drive

The CD-ROM drive is a standard device with multimedia features. This includes multi-session capability and fast access (16X-speed) for image and video data. The CD-ROM drive dimensions are 5.94 inch (149.5 mm) x 7.78 inch (196 mm) x 1.71 inch (43 mm) and the drive slot is a standard 1.6-inch (40.64 mm) bay that uses industry-standard bezels. Headphone access, eject, pin eject, and volume control are available on the front panel. Audio from the CD is available through either the front panel headphone connection, the line-out connector at the system unit rear (accessible by cabling from front to rear), or the internal speaker.

C.1.5.2 Diskette Drive

The system unit uses a standard 1.44-Mbyte diskette drive that is 1 inch (25.40 mm) high. The system-to-diskette drive interface is an 82077 style interface. Refer to the *Manual Eject Diskette Drive Specifications*, part number 805-1133, for cleaning, jumper setting, and instructions for the diskette drive.

SuperIO Diskette Drive Interface

The SuperIO component contains an onboard diskette drive controller. There is a 16-byte FIFO that buffers and supports burst and non-burst modes. The diskette drive controller handles data rates of 500 Kbps and 250 Kbps.

Supported Features

Two additional pins on the PCIO ASIC combine with the SuperIO diskette drive interface to support all standard Sun diskette drives. This includes Density_Select-type diskette drives, Density_Sense-type diskette drives, and diskette drives that use a Disk_Change signal.

Diskette Drive Connectors

Power is supplied to the diskette drive from a pigtailed connector at the power supply. The diskette drive operates from a 5-Vdc supply and uses a maximum power of 1.1 watts during operation. A maximum of 44 milliwatts is used during standby mode. The diskette drive is connected to the SCSI backplane with a 34-pin ribbon cable. The maximum cable length is 1.5 meters. From the SCSI backplane, the diskette drive is cabled to the motherboard with the SCSI connections.

Diskette Drive Signals

TABLE C-5 lists diskette drive signals by mnemonic name and provides the function.

TABLE C-5 Diskette Drive Signals by Mnemonic Name

Mnemonic Name	Function
AUTO_EJECT	When active low, AUTO_EJECT causes the diskette drive to eject its media at least 15 mm beyond the front of the device. If the drive is actively writing data when AUTO_EJECT is active, the diskette is ejected after the write is completed.
MODE_SELECT	When active low, MODE_SELECT sets the drive for a 1.2-Mbyte formatted disk. When active high, MODE_SELECT sets the drive for a 1.44-Mbyte formatted disk.
HIGH_DENSITY_IN_L	When active low, HIGH_DENSITY_IN_L indicates that a high-density disk is inserted into the drive.
INDEX	When active, INDEX indicates the beginning of each track. An active pulse is sent for each disk rotation.
DRIVE_SELECT	When set true, DRIVE_SELECT enables the drive to respond to other input signals.
MOTOR_ENABLE	When set low, MOTOR_ENABLE initiates the spindle motor rotation.
DIRECTION	When active high, DIRECTION indicates movement of the magnetic head assembly toward the outer cylinders. When active low, it indicates movement of the magnetic head assembly toward the inner cylinders.
STEP	On the trailing edge, STEP moves the magnetic head in the direction specified by DIRECTION at a rate of one cylinder per pulse.
WRITE_DATA	WRITE_DATA supplies the hard drive with the data to be written to disk provided the WRITE_GATE signal is active low.
WRITE_GATE	When active low, WRITE_GATE enables the drive write circuits. When active high, WRITE_GATE enables drive read circuits.

TABLE C-5 Diskette Drive Signals by Mnemonic Name (*Continued*)

Mnemonic Name	Function
TRACK0	When active low, TRACK0 indicates that the track zero sensor has been activated and that the heads are over the outermost cylinder.
WRITE_PROTECT	When active low, WRITE_PROTECT indicates that the inserted diskette is write-protected and that drive write operations are disabled.
READ_DATA	When active, READ_DATA enables data from the disk to be transferred to the host through this signal line.
HEAD_SELECT	When low, HEAD_SELECT selects head 1. When high, HEAD_SELECT selects head 0.
DISK_CHANGE	When low, DISK_CHANGE indicates that the drive tape medium has been changed. DISK_CHANGE is reset when a new disk is inserted and an enable signal is sent by the host.

C.1.5.3 Hard Drives

The system unit supports three SCSI hard drive capacities: 2.1-Gbyte, 4.2-Gbyte, and 9-Gbyte. The 2.1-Gbyte and 4.2-Gbyte hard drives are of the 1-inch form factor. The 9-Gbyte hard drive is of the 1.6-inch form factor. All hard drives have a single connector configuration. A drive bracket is used to mount the drive. TABLE C-6 lists the supported hard drives. The *2.1-Gbyte Disk Drive Specifications*, part number 802-7743, provides installation instructions, power requirements, and performance data for the 2.1-Gbyte hard drive. The *4.2-Gbyte Disk Drive Specifications*, part number 802-7744, provides installation instructions, power requirements, and performance

data for the 4.2-Gbyte hard drive. The *9-Gbyte Disk Drive Specifications*, part number 802-7745, provides installation instructions, power requirements, and performance data for the 9-Gbyte hard drive.

TABLE C-6 Supported Hard Drives

Form Factor Dimension	Hard Drive Capacity	Wide	RPM	Seek Time
1.00-inch (25.4 mm)	2.1 Gbyte	Yes	7200	9.5 ms
1.00-inch (2.54 mm)	4.2 Gbyte	Yes	7200	9.5 ms
1.63-inch (41.3 mm)	9.1 Gbyte	Yes	7200	9.5 ms

C.1.5.4 Optional 4-mm or 8-mm Tape Drive

The system unit supports optional 4-mm, 8-mm, QIC, or SLR tape drives. These tape drives can be installed in the system unit in lieu of the CD-ROM drive. Brief descriptions of the 4-mm, 8-mm, and QIC tape drives follow.

4-mm Tape Drive

The 4-mm tape drive is equipped with a single-ended SCSI controller and a 1-Mbyte on-drive buffer. The *12-24 Gbyte 4-mm DDS-3 Tape Drive Installation and User's Guide*, part number 802-7791, provides cleaning, jumper setting, and tape cartridge instructions for the 4-mm DDS-3 tape drive.

8-mm Tape Drive

The 8-mm tape drive is an enhanced 8-mm digital helical-scan cartridge tape subsystem. It is packaged in the industry-standard 5.25-inch half-height form factor. The *8-mm Tape Drive Specifications*, part number 802-5775, provides cleaning, jumper setting, and tape cartridge instructions for the 8-mm tape drive.

C.1.6 Keyboard and Mouse, Diskette, and Parallel Port

The keyboard and mouse, diskette, and parallel port interfaces are managed by the SuperIO component. FIGURE C-7 shows keyboard, diskette, and parallel port interface functionality. For a brief description of the SuperIO, see Section C.1.12 “SuperIO” on page C-34.

C.1.6.1 Keyboard and Mouse Port

The keyboard and mouse are connected to an 8-pin DIN connector, located on the motherboard, and to two serial ports on the SuperIO ASIC. Each serial port on the SuperIO ASIC provides 16-byte first-in-first-out (FIFO) buffering. Data is asynchronously exchanged with the keyboard and mouse at 1200 baud. Keyboard current is limited to 700 milliamperes (mA) by a resettable fuse. Only the Type-5 keyboard is supported.

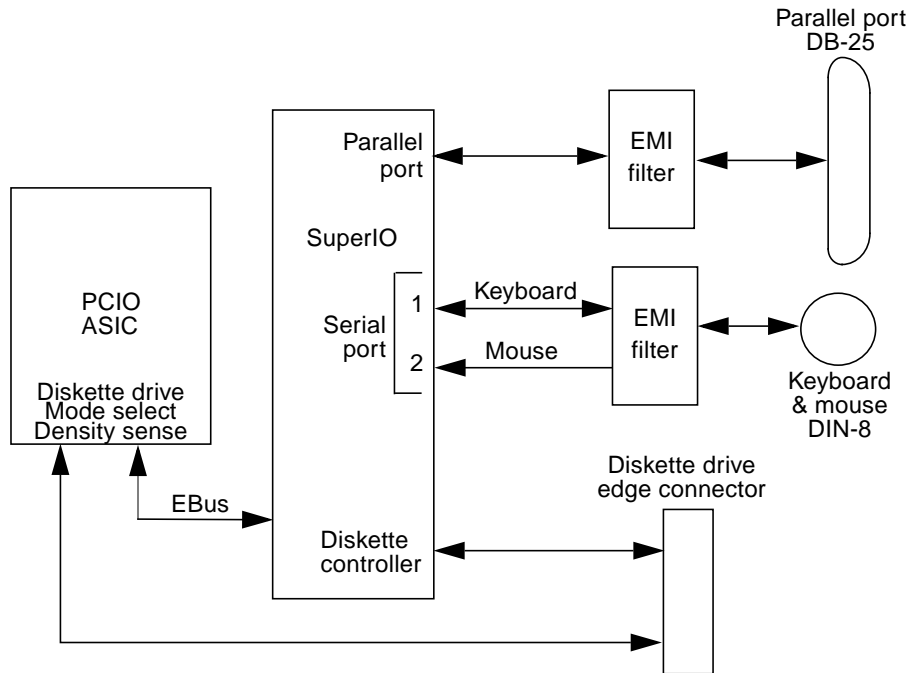

FIGURE C-7 Keyboard and Mouse, Diskette, and Parallel Port Functional Block Diagram

C.1.6.2 Diskette Port

The diskette port is supported by a diskette controller, located on the SuperIO ASIC, and the PCIO ASIC. The diskette controller is software compatible with the DP8473, DP765A, and the N82077 diskette drive standards. The SuperIO ASIC is compatible with perpendicular recording drives (2.88-Mbyte formatted diskettes) as well as standard diskette drives. There is a 16-byte FIFO for buffering and support for burst and non-burst modes. The diskette controller handles data rates of 2 Mbps, 1 Mbps, 500 Kbps, and 250 Kbps.

Note – Sun utilizes the N82077 diskette drive standard.

There are two extra pins on PCIO ASIC that combine with the SuperIO ASIC-to-diskette drive interface to support all Sun standard diskette drives. This includes diskette drives that use Density_Select and Density_Sense pins as well as diskette drives that use a Disk_Change signal. It is DMA driven through a DMA channel in the EBus interface of the PCIO ASIC. Auto eject and manual eject diskette drives (IDs of 0 or 1, respectively) are supported.

Power is supplied to the diskette drive from a separate connector pigtailed from the power supply. The diskette drive operates from the 5-Vdc supply and draws a maximum power of 1.1 watts operating and 44 milliwatts in standby mode. The diskette drive is connected to the SCSI backplane with a 34-pin ribbon cable. Maximum cable length is 1.5 meters. From the SCSI backplane, it is cabled to the motherboard with the SCSI connections.

C.1.6.3 Parallel Port

The parallel port is supported by an IEEE 1284-compatible parallel port controller that is located on the SuperIO ASIC. The parallel port controller is a PC-industry-standard controller that achieves a 2-megabits per second (Mbps) data transfer rate. The parallel port controller interface supports the ECP protocol as well as the following:

- Centronics – A widely accepted parallel port interface.
- Compatibility – Provides an asynchronous, byte-wide forward (host to peripheral) channel with data and status lines used according to their original definitions.
- Nibble mode – Provides an asynchronous, reverse (peripheral-to-host) channel, under control of the host. Data bytes are transmitted as two sequential, four-bit nibbles using four peripheral-to-host status lines.

Parallel Port Cables

The parallel port cable is IEEE 1284 compliant and consists of 18 pairs of signal wires that are double shielded with braid and foil. The maximum length of the parallel port cable is 2 meters.

Electrical Characteristics

Drivers operate at a nominal 5-Vdc transistor-transistor logic (TTL) levels. The maximum open circuit voltage is 5.5 Vdc and the minimum is -0.5 Vdc. A logic high-level signal is at least 2.4 Vdc at a source current of 0.32 mA and a logic low-level signal is no more than 0.4 Vdc at a sink current of 14 mA.

Receivers also operate at nominal 5-Vdc TTL levels and can withstand peak voltage transients between -2 Vdc and 7 Vdc without damage or improper operation. The high-level threshold is less than or equal to 2.0 Vdc and the low-level threshold is at least 0.8 Vdc. Sink current is less than or equal to 0.32 mA at 2.0 Vdc and source current is less than or equal to 12 mA at 0.8 Vdc.

C.1.7 Serial Port

The system unit incorporates two serial ports. Each serial port is synchronous and asynchronous with full modem controls. All serial port functions are controlled by a serial port controller that is electrically connected to the system through the EBus. Line drivers and line receivers control the serial port signal levels and provide RS-232 and RS-423 compatibility. Each serial port interfaces through its own DB-25 connector.

The major features of each serial port include:

- Two fully functional synchronous and asynchronous serial ports
- DB-25 connectors
- Increased baud rate speed (to 384 Kbaud, synchronous; 460.8 Kbaud, asynchronous)
- Variable edge rate for greater performance
- EBus interface

FIGURE C-8 shows a functional block diagram of the serial port.

C.1.7.1 Serial Port Components

Serial port components include a serial port controller, line drivers, and the line receivers.

The serial port controller contains 64-byte buffers on both the input and output. This enables the serial port to require less CPU bandwidth. Interrupts are generated when the buffer reaches 32 bytes or half full. The serial port controller contains its own crystal oscillator that supports rates of up to 921.6 Kbaud.

The line drivers and line receivers are compatible with both RS-232 and RS-423. Two motherboard jumpers are used to set the line drivers and line receivers to either RS-232 or RS-423 protocols. The line driver slew rate is also programmable. For baud rates over 100 K, the slew rate is set to 10 Vdc/ μ sec. For baud rates under 100 K, the slew rate is set to 5 Vdc/ μ sec.

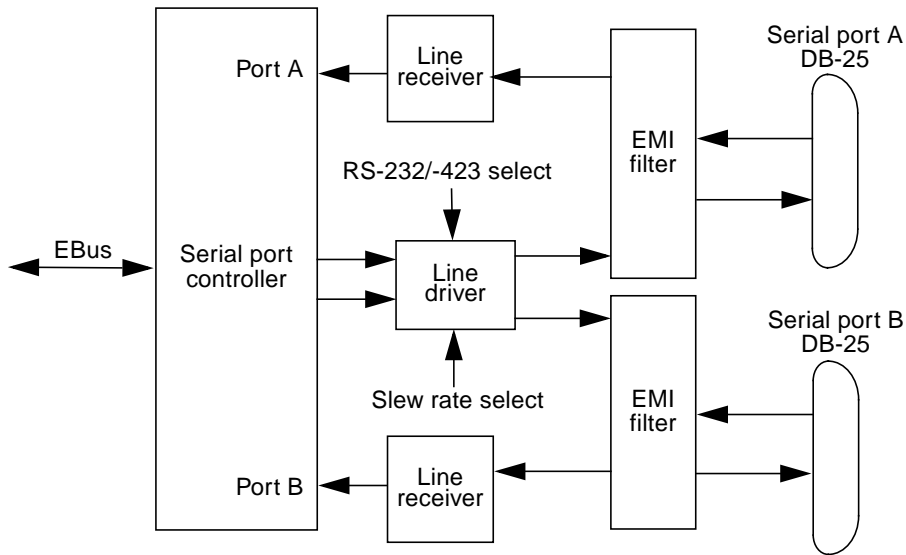

FIGURE C-8 Serial Port Functional Block Diagram

C.1.7.2 Serial Port Functions

The serial port provides a variety of functions. Modem connection to the serial port allows access to the internet. Synchronous X.25 modems are used for telecommunications in Europe. An ASCII text window is accessible through the serial port on non-graphic systems. Low-speed printers, buttonboxes (for CAD/CAM applications), and exotic devices that function like a mouse are also accessible through the serial port. The additional speed of the serial port can be used to execute communications with a CSU/DSU for a partial T1 line to the internet at 384 Kbaud per second.

C.1.7.3 EIA Levels

Each serial port supports both RS-232 and RS-423 protocols. RS-232 signaling levels are between -3 Vdc and -15 Vdc and +3 Vdc and +15 Vdc. A binary 1 (001_2) is anything greater than +3 Vdc and a binary 0 (000_2) is anything less than -3 Vdc. The signal is undefined in the transition area between -3 Vdc and +3 Vdc. The line driver switches at -10 Vdc and +10 Vdc with a maximum of -12 Vdc and +12 Vdc in RS-232 mode. RS-423 is similar except that signaling levels are between -4 Vdc to -6 Vdc and +4 Vdc and +6 Vdc. The line driver switches at -5.3 Vdc and +5.3 Vdc with a maximum of -6 V and +6 Vdc. Switching from RS-232 to RS-423 protocol is accomplished by changing jumpers J2604 and J2605. Jumper positions 1 and 2 are for RS-232 and jumper positions 2 and 3 are for RS-423.

The preferred signaling protocol is RS-423. The higher voltages of R-232 make it difficult to switch at the higher baud rates. The maximum rate for RS-232 is approximately 64 Kbaud while the maximum rate for RS-423 is 460.8 Kbaud. The system default is set to RS-232.

C.1.7.4 Synchronous Rates

The serial synchronous ports operate at any rate from 50 Kbaud to 256 Kbaud when the clock is generated from the serial port controller. When the clock is generated from an external source, the synchronous ports operate at up to 384 Kbaud. Clock generation is accurate within 1 percent for any rate that is generated between 50 Kbaud and 256 Kbaud.

C.1.7.5 Asynchronous Rates

The serial asynchronous ports support twenty baud rates that are all exact divisors of the crystal frequency (with exception for 110, which is off by less than 1 percent). Baud rates include 50, 75, 110, 200, 300, 600, 1200, 1800, 2400, 4800, 9600, 19200, 38400, 57600, 76800, 115200, 153600, 230400, 307200, and 460800.

C.1.7.6 Slew Rate and Cable Length

The maximum cable length RS-423 is 118 feet (30 meters) and the maximum cable length RS-232 is 50 feet (15.24 meters). The slew rate changes depending on the speed. For speeds less than 100 Kbaud, the slew rate is set at 5 Vdc per microsecond. For rates greater than 100 Kbaud, the slew rate is increased to 10 Vdc per microsecond. This allows maximum performance for the greater baud rates and better signal quality at the lesser baud rates.

C.1.8 Ethernet

The system unit supports 10-Mbps, 10BASE-T, twisted-pair Ethernet and 100-Mbps, 100BASE-X, media independent interface (MII) Ethernet with the use of a single magnetics module. Twisted-pair Ethernet is provided through an 8-pin RJ45 connector. MII Ethernet is provided through a 40-pin MII connector. The MII port allows connection to any cable medium, including unshielded twisted-pair (UTP), shielded twisted-pair (STP), and fiber optic accompanied by the appropriate external transceiver. The system automatically senses an external transceiver, thus disabling an on-board transceiver. The Ethernet circuitry design is based on two National Semiconductor ICs: the DP83840 (PHY) IC and the DP83223 (Twister) IC.

The PHY chip integrates a 100BASE-T physical coding sub-layer (PCS) and a complete 10BASE-T module in a single chip. It provides a standard MII to communicate between the physical signaling and the medium access control layers for both 100BASE-X and 10BASE-T operations. The PHY IC interfaces to the 100-Mbps physical-medium-dependent transceiver Twister IC.

The 100BASE-X portion of the PHY IC consists of the following functional blocks:

- Transmitter
- Receiver
- Clock generation module
- Clock recovery module

The 10BASE-T section of the PHY IC consists of the 10-Mbps transceiver module with filters.

The 100BASE-T transceiver is included in a separate Twister IC and features adaptive equalization, baseline wander correction, and transition time control on the output signals.

The 100BASE-X and 10BASE-T sections share the following functional characteristics:

- PCS control
- MII registers
- IEEE 1149.1 controller (JTAG compliance)
- IEEE 802.3u auto negotiation

The next sections provide brief descriptions of the following:

- Automatic negotiation
- External transceivers
- External cables
- Connectors
- MII power
- MII port timing

C.1.8.1 Automatic Negotiation

Automatic negotiation controls the cable when a connection is established to a network device. It detects the various modes that exist in the linked partner and advertises its own abilities to automatically configure the highest performance mode of inter-operation, namely, 10BASE-T, 100BASE-TX, or 100BASE-T4 in half- and full-duplex modes.

The Ethernet port supports automatic negotiation. At power up, an on-board transceiver advertises 100BASE-TX in half-duplex mode, which is configured by the automatic negotiation to the highest common denominator based on the linked partner.

C.1.8.2 External Transceivers

The following external transceivers are connected through the MII port:

- 6211 Micro 100BASE-FX FastEthernet transceiver
- CT4-1030 100BASE-T4 transceiver
- CFX-107X 100BASE-FX transceiver
- XF467A MII-to-AUI transceiver

C.1.8.3 External Cables

The MII port supports a 0.5-meter-long, 40-conductor, 20 signal-ground, STP cable. The single-ended impedance of the cable is 68 ohms (+/-10%). The propagation delay for each twisted-pair, measured from the MII connector to the PHY, does not exceed 2.5 nanoseconds.

The RJ45 Ethernet port supports a Category 5, UTP cable for the 100BASE-T, and a Category 3, 4, or 5 UTP cable for the 10BASE-T operation.

Note – The maximum cable segment lengths for the 100BASE-TX and 10BASE-TX are 100 meters and 1000 meters, respectively.

C.1.8.4 Connectors

A 40-pin connector is used for the MII connector. A standard 8-pin RJ45 connector with a shield is used for the AUI connector.

C.1.8.5 MII Power

A regulated 5-Vdc (+/- 5%) voltage is supplied to the PHY IC over the load range of from 0 to 750 mA. A 2-amp overcurrent protection circuit is provided by a polymer-based resettable fuse to the MII supply voltage.

MII-to-AUI connection to a 10-Mbps medium attachment unit requires a supplemental power source to meet the AUI power supply requirements. The MII-AUI converter provides the necessary supplemental power.

C.1.8.6 MII Port Timing

MII port timing encompasses two configurations involving the use of either an on-board transceiver or external transceivers. For either transceiver configuration, the MII port timing is the same because MII operates with a 40-nanosecond cycle time.

FIGURE C-9 illustrates MII being used to interconnect both integrated circuits and circuit assemblies. This enables separate signal transmission paths to exist between the reconciliation sublayer, embedded in the PCIO ASIC, and a local PHY IC, and between the reconciliation sublayer and a remote PHY IC. The unidirectional paths between the reconciliation sublayer and the local PHY IC are composed of sections A1, B1, C1, and D1. The unidirectional paths between the reconciliation sublayer and the remote PHY IC are composed of sections A2, B2, C2, and D2.

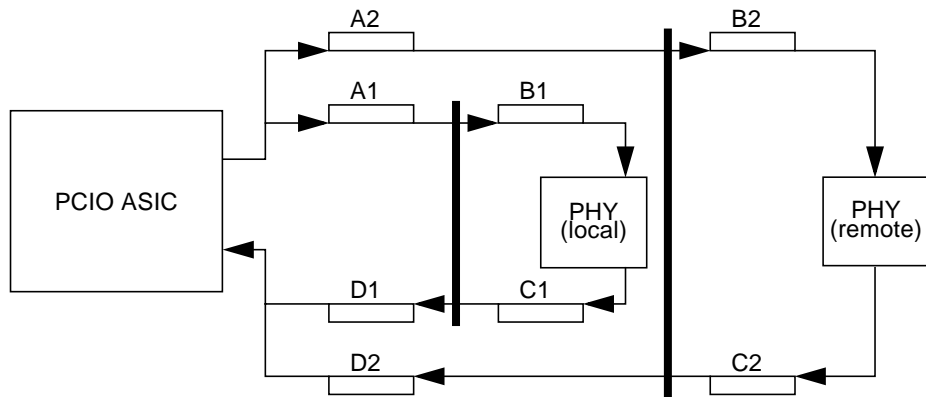

FIGURE C-9 MII Port Timing Model

C.1.9 Audio Card and Connector

The audio card provides various audio applications from telephone-quality speech to CD-quality music. The audio card supports four jacks of identical type: line in, line out, headphone out, and microphone in. TABLE C-7 lists the major features of the audio card and FIGURE C-10 illustrates a functional block diagram.

TABLE C-7 Major Features of the Audio Card

Figure Reference	Feature	Description
A	Stereo line level	Attenuated by a resistor divider network and then fed into the Line Inputs of the Codec.
B	Stereo microphone input	Buffered by a non-inverting operational amplifier (one operational amplifier for the left channel and one operational amplifier for the right channel). The left and right outputs are then fed into the left and right Mic Inputs of the Codec. A filtered +5 Vdc is fed to the signal inputs.
C	Internal CD-ROM peripheral analog outputs	Cabled to the motherboard and AC-coupled to the left and right Aux1 inputs of the Codec.
D	Codex mono-output	Fed into an active graphic equalizer to add bass boost and mid-range attenuation. Equalizer output is amplified and routed to the front mounted 16-ohm, 68-mm speaker.
E	Line output	A direct output, except E1, which enables muting of this signal. The mute function is driven from the Codec PIO lines.
F	Headphone output	Buffered by an operational amplifier to give headphone drive with low impedances of 16 ohms or more. Is independently mutable, driven from Codec PIO lines.
G	MultiMedia Codec (MMCodec)	Heart of the audio module. A single-chip, stereo, A/D and D/A converter based on delta-sigma conversion.

The audio card connector is a dual-position, standard-edge connector whose features include:

- 23 dual positions (46 total)
- 50-millimeter centerline
- 1.49 inches (3.78 cm) total length

The audio connector supports the following:

- Nine Codec address lines
- Eight Codec data lines
- Control lines: Write, Read, Codec chip select, PROM chip select, Reset
- Codec DMA support signals: playback request, playback acknowledge, capture request, and capture acknowledge
- Codec power down line
- Audio analog lines: DC volume control line
- Audio present
- Power/ground: Two +12 Vdc lines, one -12 Vdc line, one Vcc line, five digital grounds, and four analog grounds
- Two spare pins

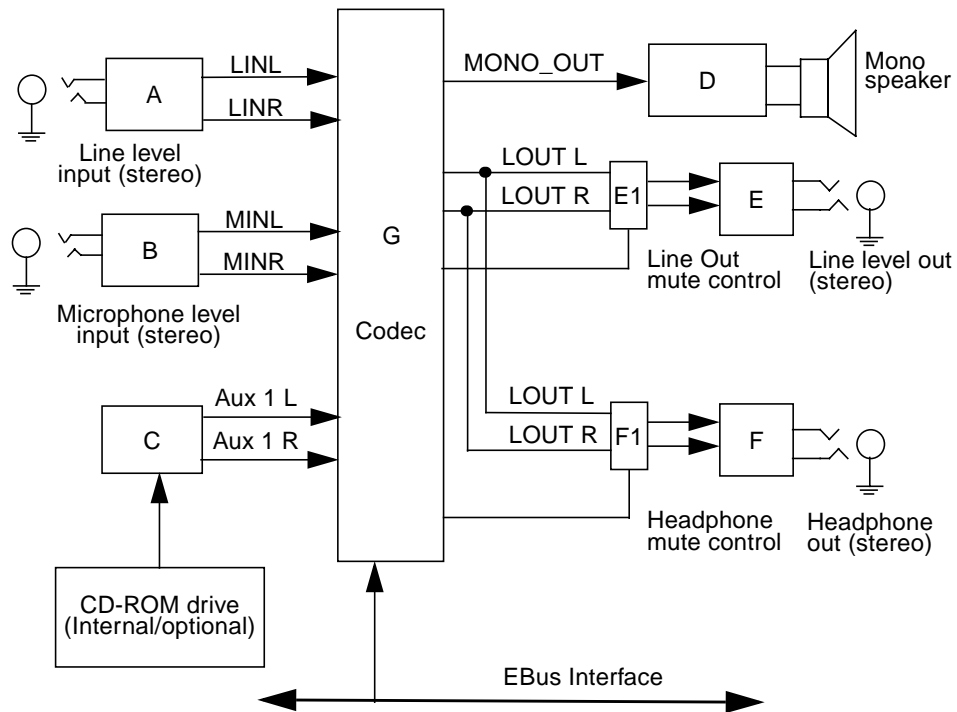

FIGURE C-10 Audio Card Functional Block Diagram

C.1.10 SCSI

The system unit implements a small computer system interface (SCSI) Fast-20 (UltraSCSI) parallel interface bus. The UltraSCSI provides the following:

- Efficient peer-to-peer I/O bus devices
- Mechanical, electrical, and timing specification definitions that support transfer rates of 20 or 40 Mbytes per second (corresponding to the data path width of an 8-bit, or 16-bit bus, respectively)
- Peak bandwidth of 40 Mbytes per second (with implemented 16-bit bus width)

The internal SCSI bus is terminated at each end. One set of terminators is located close to the CD-ROM drive connector on the CD-ROM SCSI card. A second set of terminators is located close to the 68-pin external SCSI connector. FIGURE C-11 shows the SCSI bus configuration.

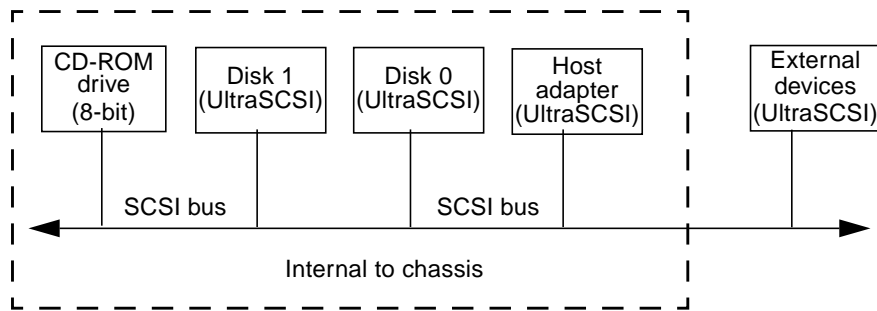

FIGURE C-11 Configuration for the SCSI Bus

C.1.10.1 Host Adapter

The host adapter is a Symbios Logic PCI-SCSI I/O processor IC. The host adapter and all target devices comply with the UltraSCSI single-ended drivers and receivers characteristics. The electrical characteristics of the output buffers include:

- V_{ol} (output low) equals 0 to 0.5 Vdc with I_{ol} at 48 mA (signal asserted)
- V_{oh} (out high) equals 2.5 to 3.7 Vdc (signal negated)
- t_{rise} (rising slew rate) equals 520 mV per nanosecond maximum (0.7 to 2.3 Vdc)
- t_{fall} (falling slew rate) equals 520 mV per nanosecond maximum (2.3 to 0.7 Vdc)

The UltraSCSI electrical characteristics for the host adapter and target device include:

- V_{il} (input low) equals 1.0 Vdc maximum (signal true)
- V_{ih} (input high) equals 1.9 Vdc minimum (signal false)
- I_{il} (input low current) equals +/- 20 μ A at V_i equals 0.5 Vdc
- I_{ih} (input high current) equals +/- 20 μ A at V_i equals 2.7 Vdc
- Minimum input hysteresis equals 0.3 Vdc

C.1.10.2 Supported Target Devices

The SCSI subsystem supports a maximum of four internal devices, including the host adapter. The CD-ROM drive is a narrow device. A unipack with one drive or a six-pack, accommodating six drives, can be used as external devices. TABLE C-8 lists the target devices supported by the SCSI subsystem.

TABLE C-8 SCSI Subsystem Supported Target Devices

Target Device	Comment
Internal disks	Up to two 3.5-inch x 1.6-inch disks (2.1, 4.2, or 9.1-Gbyte). All internal disks are Fast-20 compliant.
Internal CD-ROM drive	Headphone jack with volume control. CD-ROM drive is a narrow SCSI device.
Internal tape drive	Optional 12/24-Gbyte DDS3, 4-mm, supporting narrow SCSI; optional 14-Gbyte 8-mm, supporting wide SCSI.
External SPARCstorage UniPack	Disk 2.1- or 4.2-Gbyte, Fast-20 compliant.
External SPARCstorage SixPack	Disk 2.1- or 4.2-Gbyte, Fast-20 compliant.

C.1.10.3 External Cables

External UltraSCSI-compliant SCSI cables have an impedance of 90 ohm (+/- 6 ohm) and are required for UltraSCSI interface. Sun's implementation of UltraSCSI requires that the total SCSI bus length be limited to no more than approximately 20 feet (6 meters) with up to 12 Sun compensated devices. Due to the considerably short bus length, an approximate 32-inch (0.8-meter) UltraSCSI-compliant external cable is supported in addition to an approximate 6.5-foot (2-meter) UltraSCSI-compliant external cable.

C.1.10.4 Internal SCSI Subassembly

The internal SCSI subassembly consists of two cable assemblies and two SCSI cards. The SCSI subassembly is attached to the motherboard using an insulation displacement connector (IDC) receptacle attached to a 80-conductor cable. In addition to the SCSI signals, the 80-conductor cable carries diskette drive and system LED signals to the SCSI backplane card. The IDC receptacle mates with a right angle plug that is mounted on the motherboard in close proximity to the test edge connector.

The 80-conductor cable attaches on the other end to the SCSI backplane card with another IDC connector. The SCSI backplane card incorporates two SCA-2 connectors for mounting the hard drives, a four-circuit power connector to supply 5-Vdc and 12-Vdc power to the hard drives, a 34-pin diskette drive signal connector, and a green, right-angle LED.

A 68-conductor cable exits the SCSI backplane card, carrying 27 SCSI signals and the Termpower to the internal CD-ROM drive (or tape drive). The SCSI backplane card houses the CD-ROM drive connector and three SCSI bus terminators. The Termpower is routed through the SCSI subassembly to connect to the terminators on the SCSI backplane card in support of the multi-host configuration. FIGURE C-12 functionally shows the internal SCSI subassembly.

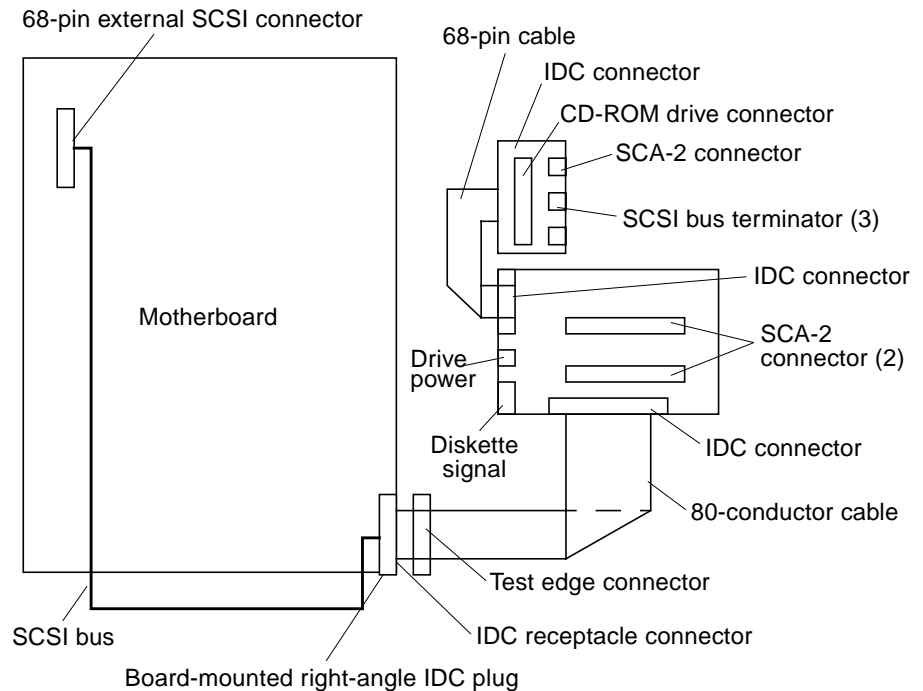

FIGURE C-12 SCSI Subassembly Functional Block Diagram

C.1.10.5 SCSI ID Selection

The motherboard host adapter is assigned the SCSI identification of 7. The two internal drives attached to the SCA-2 connectors have a SCSI identification of 0 and 1, while the CD-ROM has an identification of 6.

C.1.11 ASIC

The system unit achieves a high level of integration through application-specific integrated circuits (ASICs). With exception of the UltraBMX ASIC, all ASICs are 1149.1 (JTAG) compliant. The following ASICs are highlighted and are described in the following sections:

- System controller uniprocessor plus (SC_UP+)
- UltraBMX
- PCI-to Ebus/Ethernet controller (PCIO)
- UPA-to-PCI bridge (U2P)
- Frame buffer controller (FBC)
- Reset, interrupt, scan, and clock (RISC)

Also included in this section are brief discussions of the SuperIO component.

C.1.11.1 SC_UP+

The system controller uniprocessor plus (SC_UP+) ASIC regulates the flow of requests and data throughout the system unit. The SC_UP+ ASIC also controls the resets being transmitted to all UPA clients. The SC_UP+ ASIC provides the following:

- Supports multiple outstanding loads (up to three read transactions in Class 0)
- Supports dual UPA graphics
- Supports two outstanding write-backs and write-back cancels
- Provides enhanced memory subsystem comprised of two memory banks delivering higher memory bandwidth
- Supports up to 16 DIMMs, yielding a maximum memory configuration of 2 Gbytes.
- Supports 10-nanosecond and 12-nanosecond system timing in memory wave forms
- Queue depth of eight Class 1 transactions from the CPU module for higher graphics performance

The SC_UP+ ASIC performs the following functions:

- Accepts UPA request packets from the two masters, CPU module and U2P ASIC; routes the request packets to the correct slave destination.
- Maintains cache coherence between the merger buffer in the U2P ASIC and the CPU module cache.
- Implements blocking to guarantee all requests are properly ordered.
- Controls the UltraBMX ASIC, hence controls the data flow throughout the system.
- Contains a memory controller that supplies address and control lines to memory.
- Receives and distributes resets to all system UPA clients.

- Contains logic for the CPU module wake up.

C.1.11.2 UltraBMX

The UltraBMX ASIC is the hub of all data transfers in the system unit. The UltraBMX ASIC permits the implementation of a high-bandwidth/-interleaved dual bank memory system. It coordinates among memory (two buses, each 288 bits wide), the processor UPA bus (144 bits wide), and the I/O UPA bus (72 bits wide). Data transfers take place among any of the ports, sliced into 18 parts.

C.1.11.3 PCIO

The PCI-to-EBus/Ethernet controller (PCIO) ASIC performs dual roles: PCI bus-to-EBus bridging and Ethernet control. The PCIO ASIC provides the electrical connection between the PCI bus and all other I/O functions. In addition, the PCIO ASIC also contains an embedded Ethernet controller to manage Ethernet transactions and provides the electrical connection to slower on-board functions, such as the Flash PROM and the audio module.

C.1.11.4 U2P

The UPA-to-PCI bridge (U2P) ASIC provides an I/O connection between the UPA bus and the two PCI buses. The U2P ASIC features include:

- Full master and slave port connection to the high-speed UPA interconnect. The UPA is a split address/data packet-switched bus that has a potential data throughput rate of greater than 1 Gbyte per second. UPA data is ECC protected.
- Two physically separate PCI bus segments with full master and slave support:
 - 66-MHz PCI bus segment (PCI bus A): 3.3-Vdc I/O signaling, 64-bit data bus, compatible with the PCI 66-MHz extensions, support for up to four master devices (at 33 MHz only)
 - 33-MHz PCI bus segment (PCI bus B): 5.0-Vdc I/O signaling, 64-bit data bus, support for up to six master devices
- Two separate 16-entry streaming caches, one for each bus segment, for accelerating some kinds of PCI DVMA activity. Single IOMMU with 16-entry TLB for mapping DVMA addresses for both buses (IOMMU used to translate 32-bit or 64-bit PCI addresses into 41-bit UPA addresses).
- A mono-vector dispatch unit for delivering interrupt requests to CPU module, including support for PCI interrupts from up to six slots, as well as interrupts from on-board I/O devices.

C.1.11.5 FBC

The frame buffer controller (FBC) ASIC is the graphics draw ASIC that provides interface between the UPA and the 3DRAM. The FBC ASIC provides 2-D and 3-D graphics draw acceleration. Highlights of the FBC ASIC features include:

- UPA slave device with write-mostly philosophy
- Supports single buffered and DBZ configurations
- Interfaces with 3DRAM to achieve accelerated graphics performance
- Supports frame buffer-to-frame buffer copy
- Supports viewport clipping, picking, and pixel processing
- Supports byte, plane masks, raster operations, blend operations, and conditional writes in 3DRAM
- 83.3-MHz UPA operation and 75-MHz 3DRAM operation
- 3.3-Vdc and 5-Vdc (for RAMDAC ASIC) supply voltage

C.1.11.6 RISC

The reset, interrupt, scan, and clock (RISC) ASIC implements four functions: reset, interrupt, scan, and clock. Generation and stretching of the reset pulse is performed in this ASIC. Interrupt logic concentrates 42 different interrupt sources into a 6-bit code, which communicates with the U2P ASIC. It also integrates a JTAG controller.

Highlights of the RISC ASIC features include:

- Determines system clock frequency
- Controls reset generation
- Performs PCI bus and miscellaneous interrupt concentration for U2P
- Controls Flash PROM programming, frequency margining, and lab console operation
- 33-MHz operation
- 3.3-Vdc and 5-Vdc supply voltage

C.1.12 SuperIO

The SuperIO is a commercial, off-the-shelf component that controls the keyboard, diskette, and parallel port interfaces. It contains a DMA-driven diskette controller, two serial port controllers, an IEEE 1284 parallel port interface, and an IDE disk interface (not currently used). The SuperIO drives the various ports directly with some EMI filtering on the keyboard and parallel port signals. Support for mixed voltage modes and power management features for low power operation are also included. Features of the SuperIO include:

- Two independent serial ports used for keyboard and mouse

- N82077 diskette drive interface
- IEEE 1284 parallel port interface

C.1.13 Power Supply

The system unit uses a 300-watt power supply that operates under the voltage range of 85 to 264 volts root-mean-square (Vrms) and a frequency range of 47 to 63 Hz. The maximum input current is 7 amps and the inrush current is limited to 80 peak amps.

The power supply output voltages are listed in TABLE C-9. The power supply continues to regulate all outputs for 20 milliseconds after AC power is removed.

TABLE C-9 Power Supply Output Voltages

Output	Voltage (Vdc)	Max Current (A)	Regulation Band
1	3.3	50.0	3.23 to 3.43
2	5.0	30.0	4.85 to 5.25
3	12.0	6.0	11.65 to 12.6
4	-12.0	0.4	-12.6 to -11.4
5	2.5 to 3.5	16.0	+/- 2%

Note – The combined power of output 1 and output 2 is less than 235 watts.

C.1.14 Control Signals

With the exception of the `PowerOn` signal, all power supply control signals are at TTL signal levels. TABLE C-10 lists these control signal values.

TABLE C-10 Power Supply Control Signals

Parameter	Min	Max
V _{OH} (high-level output voltage)	2.4 Vdc	
V _{OL} (low-level output voltage)		0.4 Vdc
V _{IH} (high-level input voltage)	2.0 Vdc	
V _{IL} (low-level input voltage)		0.8 Vdc

C.1.14.1 Remote Enable PowerOn and PowerOff

A remote interface can disable the DC outputs with a momentary low signal to the PowerOff input and enable the DC outputs with a momentary low signal to the PowerOn input. Both signals are interfaced to the power supply through the motherboard.

C.1.14.2 ON/OFF Functionality

The system unit uses a latching relay to remember the state of the power supply. This system uses a momentary ON/OFF switch and enables other parts of the system (such as software or the keyboard switch) to control the state of power supply.

Turning the System Unit On

The system unit can be turned on in the following ways:

- Keyboard switch
- Set the TOD timer to wake-up at a given time
- Power switch on front of the system

Turning the System Unit Off

The system unit can be turned off in the following ways:

- Type `poweroff` from shell (this does a graceful shutdown)
- Halt system and type `poweroff` from the OBP
- Activate Energy Star
- Press the keyboard Shift and Power key simultaneously from the OBP
- Press power switch on front of the system unit

Note – Energy Star powers off the system only after a period of inactivity and does not turn the system back on. Energy Star can only be set to be on during a certain time frame, such as from 6 p.m. to 7 a.m. and only comes back on through: TOD, keyboard, or power switch. Energy Star is not a part of the operating system and must be loaded by the user.

Note – When enabled, Energy Star will also checkpoint the system unit from UNIX.

C.1.14.3 System Unit Power Budget

The following sections present the system unit power budgets.

CPU Modules

TABLE C-11 lists the power estimate for the 3.3-ns CPU module and TABLE C-12 lists the power estimate for the 4-ns CPU module.

TABLE C-11 Power Estimate (3.3-ns CPU Module)

Description	Qty	2.5-Vdc Core (A)		3.3-Vdc System (A)		Watt (max)	
		ea.	sub	ea.	sub	ea.	sub
SRAM (4 data +1 tag)	5			0.909	8.18	3.00	27.00
CPU module core + I/O	1	13.33	13.33			33.33	33.33
CPU module I/O	1			0.27	0.27	0.90	0.90
BDB (@ 2.5 Vdc, EPIC 4)	2	1.04	2.08			2.6	5.20
CPU module	1		15.41		8.45		66.43

TABLE C-12 Power Estimate (4-ns CPU Module)

Description	Qty	2.5-Vdc Core (A)		3.3 Vdc System (A)		Watt (max)	Watt (max)
		ea.	sub	ea.	sub	ea.	sub
SRAM (8 data +1 tag)	9			0.76	6.82	2.50	22.50
CPU module core + IO	1	10.00	10.00			25.00	25.00
CPU module IO	1			0.27	0.27	0.89	0.89
BDB (@ 3.3 Vdc, TGC3000)	2			1.21	2.42	2.6	7.99
CPU Module (est. @ 4 ns)	1		10.00		9.51		56.38

PCI Cards

The PCI card power budget supports a total of 60 watts, which is distributed among four PCI cards in an arbitrary way as long as the total PCI power does not exceed 60 watts. TABLE C-13 lists the power estimate for the 5-Vdc PCI card and TABLE C-14 lists the power estimate for the 3.3-Vdc PCI card.

TABLE C-13 Power Estimate for the 5-Vdc PCI Card

Voltage Rail (Vdc)	PCI Cards (Max No.)	Current each (A)	Current total (A)	Total Power (W)
5	4	3.0	12.0	
3.3	4	0	0	<= 60
+12	4	0.5	2.0	
-12	4	0.1	0.4	

TABLE C-14 Power Estimate for the 3.3-Vdc PCI Card

Voltage Rail (Vdc)	PCI Cards (Max No.)	Current each (A)	Current total (A)	Total Power (W)
5	4	0	0	<= 60
3.3	4	4.55	18.18	
+12	4	0.5	2.0	
-12	4	0.1	0.4	

Memory System

TABLE C-15 lists the power estimates for the memory subsystem.

TABLE C-15 Power Estimate for the Memory Subsystem

Number of DIMMs	WC current total [A]	Total Power @5 Vdc [W]
16	9.33	46.66

Mass Storage Devices

TABLE C-16 lists power estimates for specific storage devices

TABLE C-16 Power Estimates for the Storage Devices

Description	Qty	5-Vdc System (A)		2.5-Vdc Core (A)		3.3-Vdc System (A)		12-Vdc System (A)		-12Vdc System [A]		Watt (max)	
		ea.	sub	ea.	sub	ea.	sub	ea.	sub	ea.	sub	ea.	sub
Motherboard 16-DIMM no CPU module	1	9.9	9.9			4.25	4.25	0.23	0.23			66.2	66.2
CPU Module	1			15.4	15.4	9.5	9.5					66.4	66.4
Diskette drive	1	0.3	0.3									1.20	1.2
Hard drive, 1-inch 7200 rpm	0	1.2	0.0					1.2	0			15.0	0.0

TABLE C-16 Power Estimates for the Storage Devices (Continued)

Description	Qty	5-Vdc System (A)		2.5-Vdc Core (A)		3.3-Vdc System (A)		12-Vdc System (A)		-12Vdc System [A]		Watt (max)	Watt (max)
Hard drive, 1.6-inch 7200 rpm	2	1.5	3.0					1.65	3.3			20.0	40.0
Mammoth tape	1	2.4	2.4					0.7	0.7			17.0	17.0
UPA graphics	0	0.4	0			5	0	0.1	0			20	0.0
PCI (5 Vdc)	4	3	12					0.5	2.0	0.1	0.4	15	60.0
PCI (3.3 Vdc)						4.6	18.2						
MII	1	0.8	0.8									4	4.0
Fan	2							0.4	0.8			4.8	9.6
Total		20	28	15	15	27	32	5	7	0.1	0.4	185	264

C.1.15 Built-In Speaker

The system unit contains a cost-effective speaker. The speaker provides audio functionality in the absence of external speakers. Audio from all sources is available. TABLE C-17 lists the built-in speaker specifications.

TABLE C-17 Built-In Speaker Specifications

Speaker	Specifications
Power output	1.5W average, 3W peak
Distortion	0.02%, typical at 1 kHz
Impedance	16 Ohms +/- 20%
Frequency response	150 Hz-17 kHz +/- 0.5 dB

C.1.16 Microphone

A SunMicrophone™ II mono microphone is included with each system unit.

C.1.17 Standard System Facilities

In addition to the previously listed features, the system unit provides the following:

- TOD/NVRAM for clock and identification functions.
- Flash PROM for operating system initialization. The Flash PROM is re-programmable through UNIX and OBP utilities.
- Single LED for status. If the LED is lit, the system unit has power and some functional intelligence through OBP.

C.2 Motherboard

FIGURE C-13 illustrates a block diagram of the system unit motherboard.

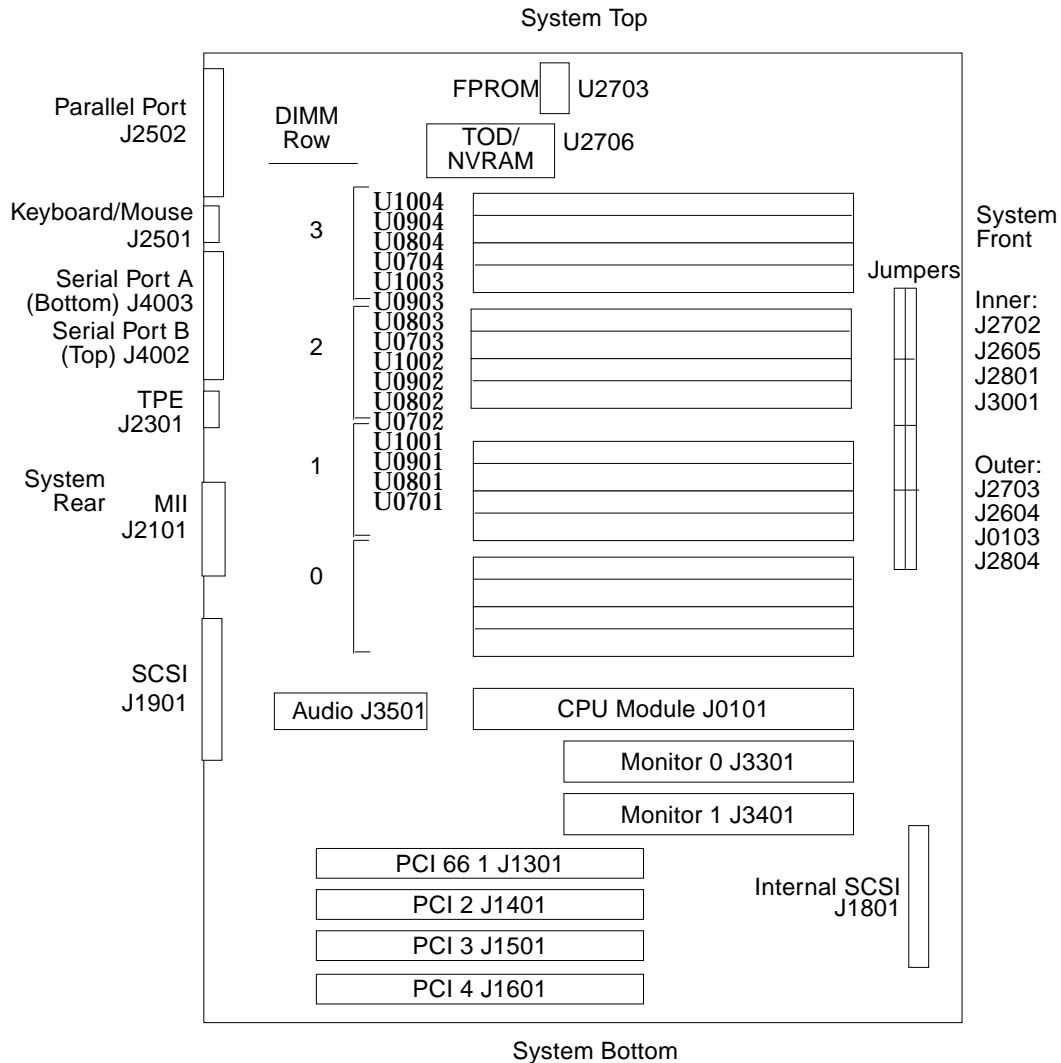

J2703=FEPROM R/W, J2605 + J2604=RS423/
 232.
 J3001=UPA Clk /2 /3, J2804=FEPROM Boot Hi-

FIGURE C-13 System Unit Motherboard Functional Block Diagram

C.3 Jumper Descriptions

Jumper descriptions include brief overviews of serial port jumpers, Flash PROM jumpers, and additional motherboard jumper and connector blocks.

FIGURE C-14 shows typical jumper layout patterns. Jumpers are identified on the motherboard by J designations. Jumper pins are located immediately adjacent to the J designator. Pin 1 is marked with an asterisk in any of the positions shown (FIGURE C-15).

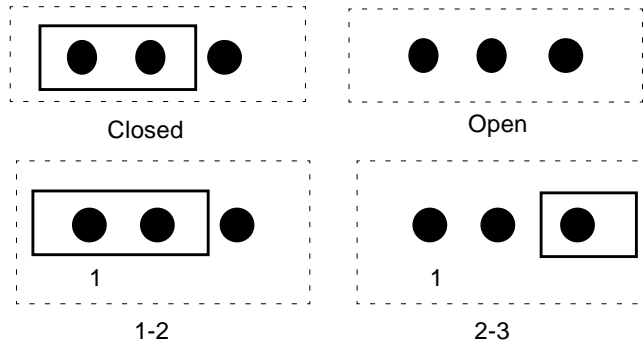

FIGURE C-14 Selected Jumper Settings

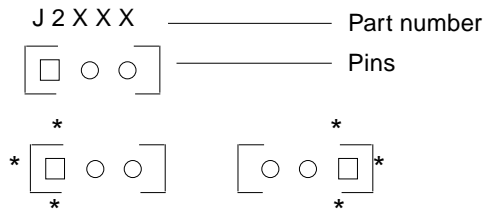

FIGURE C-15 Identifying Jumper Pins

C.3.1 Serial Port Jumpers

Serial port jumpers J2604 and J2605 can be set to either RS-423 or RS-232 serial interface. The jumpers are preset for RS-423. RS-232 is required for digital telecommunication within the European Community. TABLE C-18 identifies serial port jumper settings. If the system is being connected to a public X.25 network, the serial port mode jumper setting may need to change from RS-423 to RS-232 mode.

To change the serial port mode jumper setting:

- 1. Power off the system unit.**

See Section 6.2 “Powering Off the System Unit” on page 6-3.

- 2. Remove the side access cover.**

See Section 7.1 “Removing the Side Access Cover” on page 7-1.



Caution – Use proper ESD grounding techniques when handling components. Wear an antistatic wrist strap and use an ESD-protected mat. Store ESD-sensitive components in antistatic bags before placing them on any surface.

- 3. Attach the wrist strap.**

See Section 7.2 “Attaching the Wrist Strap” on page 7-4.

- 4. Locate the jumpers on the motherboard and change the selection of jumpers J2604 and J2605 to position B.**

- 5. Detach the wrist strap.**

- 6. Replace the side access cover.**

See Section 7.3 “Replacing the Side Access Cover” on page 7-5.

- 7. Power on the system unit.**

See Section 6.1 “Powering On the System Unit” on page 6-1.

TABLE C-18 Serial Port Jumper Settings

Jumper	Pins 1 + 2 Select	Pins 2 + 3 Select	Default Jumper on Pins
J2604	RS-232	RS-423	2 + 3
J2605	RS-232	RS-423	2 + 3

C.3.2 Flash PROM Jumpers

Flash PROM jumpers J2703 and J2704 are for reprogramming specific code blocks and remote programming of the Flash PROM. TABLE C-19 identifies the Flash PROM jumper settings. The default shunt setting of J2703 is on pins 1 and 2. Placing the shunt on pins 2 and 3 enables reprogramming of the Flash PROM.

TABLE C-19 Flash PROM Jumper Settings

Jumper	Pins 1 + 2 Select	Pins 2 + 3 Select	Default Jumper on Pins	Signal Controlled
J2703	Write protect	Write Enable	1 + 2	FLASH PROM PROG ENABLE
J2804	High half booting	Normal Booting	2 + 3	XOR LOGIC SET

C.4 Enclosure

The system unit uses an enclosure that reflects style, ergonomics, serviceability, functionality, versatility, and quality. Physical orientation allows for a rack-mount, desktop, or under desk installation. The enclosure design complies with all necessary environmental and regulatory specifications.

C.4.1 Enclosure Basics

Overall dimensions of the enclosure are 17.70 inches (45.00 cm) x 7.50 inches (19.00 cm) x 17.60 inches (49.60 cm). The enclosure houses:

- One 3.5-inch diskette drive
- One 1.6-inch CD-ROM drive
- One spare 3.5-inch device slot

Note – The CD-ROM drive slot is used for either the CD-ROM drive or optional 2.5-Gbyte, 4-mm, 8-mm, or SLR tape drives.

- Two 1-inch single-connector 3.5-inch hard drives
- One plug-in UltraSPARC module
- Sixteen DIMMs

- Four PCI slots
- One UPA64S module

C.4.2 Enclosure Features

Enclosure features include:

- Good access for internal upgrades and service
- Optimized motherboard layout
- Graphics expansion module (UPA64S connector)
- Processor placed on plug-in module; allows for upgrades
- All standard connectors and no splitter cables on rear panel

C.5 Environmental Compliance

The system unit meets or exceeds the specifications defined by the “Controlled Office” classification of the 990-1146-03, Rev A document.

C.6 Agency Compliance

The system unit complies with international and domestic regulatory requirements for safety, ergonomics, EMI, immunity, electrical, and telecommunication.

Glossary

- 10BASE-T** An evolution of Ethernet technology that succeeded 10BASE5 and 10BASE2 as the most popular method of physical network implementation. A 10BASE-T network has a data transfer rate of 10 megabits per second and uses unshielded twisted-pair wiring with RJ-45 modular telephone plugs and sockets.
- 100BASE-T** Also known as Fast Ethernet, an Ethernet technology that supports a data transfer rate of 100 megabits per second over special grades of twisted-pair wiring. 100BASE-T uses the same protocol as 10BASE-T. There are three subsets of the 100BASE-T technology: 100BASE-TX defines digital transmission over two pairs of shielded twisted-pair wire. 100BASE-T4 defines digital transmission over four pairs of unshielded twisted-pair wire. 100BASE-TX defines digital transmission over fiber optic cable.
- ADC** Analog-to-digital converter. A device that translates analog signals to digital signals.
- address** A unique location within computer or peripheral memory. Reference made to an address is usually for retrieving or storing data.
- address bus** A hardware pathway, typically consisting of from 20 to 32 separate lines, that carries the signals specifying locations in a computer's memory. The address bus enables the microprocessor to select a specific location in memory for transfer of data via the data bus.
- ANSI** American National Standards Institute. An organization that reviews and approves product standards in the United States. In the electronics industry, its work enables designers and manufacturers to create and support products that are compatible with other hardware platforms in the industry.
- ASIC** Application-specific integrated circuit.
- ASP** Authorized service provider.

- asynchronous** (1) Without regular time relationship; unexpected and unpredictable with respect to the execution of a program's instructions. Contrast with synchronous. (2) A form of data transmission in which information is sent one character at a time, with variable time intervals between characters; generally used in communicating via modem. Asynchronous transmission does not use a separate clock signal to enable the sending and receiving units to separate characters by specific time periods. Instead, each transmitted character consists of a number of data bits (the character itself) preceded by a "begin character" signal, called a start bit, and ending with an optional parity bit followed by one or more "end character" signals, called stop bits.
- audio port** A circuit to which the computer sends signals to be output as audible tones. The circuit is a digital-to-analog converter.
- baud rate** The rate at which information is transmitted between devices; for example, between a terminal and the computer. Often incorrectly assumed to indicate the number of bits per second (bps) transmitted, baud rate actually measures the number of events, or signal changes, that occur in 1 second. Because one event can actually encode more than one bit in high-speed digital communications, baud rate and bits per second are not always synonymous, and the latter is the more accurate term to apply to modems. For example, a so-called 9600-baud modem that encodes four bits per event actually operates at 2400 baud but transmits 9600 bits per second (2400 events times 4 bits per event) and thus should be called a 9600-bps modem.
- big-endian** A format for storage or transmission of binary data in which the most significant bit (or byte) comes first (the word is stored "big-end-first"). Contrast with little-endian.
- bit** Short for "binary digit." Indicates the smallest unit of information stored in a digital memory. Binary digits indicate two possible values: on and off.
- boot** A term used to identify the process of reading initial software into the computer.
- boot PROM** In Sun workstations, contains the PROM monitor program, a command interpreter used for booting, resetting, low-level configuration, and simple test procedures.
- bps** Bits per second.
- bus** (1) A circuit over which data or power is transmitted, one that often acts as a common connection among a number of locations. (2) A set of parallel communication lines that connect the major components of a computer system, including CPU, memory, and device controllers.
- byte** A group of adjacent binary digits (bits) operated on by the computer as a unit. The most common size byte contains eight binary digits.

CDE	Common desktop environment. A graphical user interface running on UNIX.
CD-ROM	Compact disc, read-only memory. A form of storage characterized by high capacity (roughly 600 megabytes) and the use of laser optics rather than magnetic means for reading data.
chip	(1) A small chunk of silicon bearing the equivalent of a large number of electrical components. (2) An integrated circuit (IC).
codec	An encoder-decoder.
console	A terminal, or a dedicated window on the screen, where system messages are displayed.
CRC	Cycle-redundancy check. (1) An error check in which the check key is generated by a cyclic algorithm. (2) A system of error checking performed at both the send and receiving station after a block-check character (BCC) has been accumulated.
DAC	Digital-to-analog converter. A mechanical or electronic device used to convert discrete digital numbers to continuous analog signals.
data bus	A set of hardware lines (wires) used for data transfer among the components of a computer system.
DBZ	Double buffer with Z.
DCE	Data communication equipment. A type of hardware, such as a modem, that is responsible for encoding a digital signal for delivery to a compatible DCE connected by a data link.
default	A preset value that is assumed to be correct unless changed by the user.
DIMM	Dual in-line memory module. A small printed circuit card that contains dynamic random-access memory chips.
DIN connector	Deutsch Industrie Norm. A multipin connector conforming to the specification of the German national standards organization.
DIP	Dual in-line package. Refers to the physical geometry of an integrated circuit or other electronic package; rectangular, with pins on the two longer sides.
DIP switch	A multi-sectioned switch that has DIP geometry.
DMA	Direct memory access. The transfer of data directly into memory without supervision of the processor. The data is passed on the bus directly between the memory and another device.

dpi	Dots per inch.
DPS	Data path scheduler. Controls all data flow that coordinates the activity of the BMX chips.
DRAM	Dynamic random-access memory. A read/write dynamic memory in which the data can be read or written in approximately the same amount of time for any memory location.
DTAG	Dual tag or data tag.
DTE	Data terminal equipment. That part of a data station that serves as a data source, data sink, or both, and provides for the data communication control function according to protocols.
ECC	Error checking and correction. The detection, in the processing unit, and correction of all single-bit errors, plus the detection of double-bit and some multiple-bit errors.
ECP	Extended capability port. An IEEE 1284 standard.
EMI	Electrostatic magnetic interference. Electrical phenomena that directly or indirectly contributes to a degradation in performance of an electronic system.
Ethernet	A type of local area network that enables real-time communication between machines connected directly together through cables. Ethernet was developed by Xerox in 1976, originally for linking minicomputers at the Palo Alto Research Center. A widely implemented network from which the IEEE 802.3 standard for contention networks was developed, Ethernet uses a bus topology (configuration) and relies on the form of access known as CSMA/CD to regulate traffic on the main communication line. Network nodes are connected by coaxial cable (in either of two varieties) or by twisted-pair wiring.
FBC	Frame buffer controller. An ASIC responsible for the interface between the UPA and the 3DRAM. Also controls graphic draw acceleration.
FBRAM	Frame buffer RAM. A special type of DRAM used in high-speed frame buffers.
FIFO	First-in first-out.
Flash PROM	Flash programmable read-only memory. Can be reprogrammed by a voltage pulse or a flash of light.
Gbyte	Gigabyte. One billion bytes.
IDC	Insulation displacement connector.

I/O	Input/output. Refers to equipment used to communicate with a computer, the data involved in that communication, the media carrying the data, and the process of communicating that information.
ISO	International Organization for Standardization. An international agency that reviews and approves independently designed products for use within specific industries. ISO is also responsible for developing standards for information exchange.
Kbyte	Kilobyte. A unit of measure equal to 1024 bytes.
kHz	Kilohertz. 1000 Hertz.
LED	Light-emitting diode.
little-endian	A format for storage or transmission of binary data in which the least significant byte (bit) comes first.
Mbyte	Megabyte. One million bytes.
MBps	Megabyte per second.
Mbps	Megabit per second.
MHz	Megahertz. One million cycles per second.
MII	Media independent interface. A 40-pin miniature-D connector that provides the electrical interface between some Sun systems and 10BASE-T or 100BASE-T Ethernet network transceivers.
modem	Short for modulator/demodulator. A device that enables a machine or terminal to establish a connection and transfer data through telephone lines. Because a computer is digital and a telephone line is analog, modems are needed to convert digital into analog and vice versa. When transmitting, modems impose (modulate) a computer's digital signals onto a continuous carrier frequency on the telephone line. When receiving, modems sift out (demodulate) the information from the carrier and transfer it in digital form to the computer. Modems operating over telephone lines typically transmit at speeds ranging from 300 to 9600 baud. Higher rates of operation are also possible but are generally constrained by the limitations of the telephone lines themselves.
motherboard	The main circuit board containing the primary components of a computer system to which other boards may be attached.
ns	Nanosecond.
NVRAM	Non-volatile random-access memory. Stores system variables used by the boot PROM. Contains the system <code>hostID</code> number and Ethernet address.

- OBP** OpenBoot PROM. A routine that tests the network controller, diskette drive system, memory, cache, system clock, network monitoring, and control registers.
- PCI bus** Peripheral component interconnect. A 32-bit bus providing a maximum of 132 Mbytes per second data transfer rate. PCI devices have autoconfiguration capabilities and do not have to be configured by users.
- PCIO** PCI-to-EBus/Ethernet controller. An ASIC that bridges the PCI bus to the EBus, enabling communication between the PCI bus and all miscellaneous I/O functions, as well as the connection to slower on-board functions.
- PCMCIA** Personal Computer Memory Card International Association. A standard that describes a compact hardware interface that accepts a variety of devices.
- PID** Process ID. A unique, system-wide, identification number assigned to a process.
- POR** Power-on reset.
- POST** Power-on self-test. A set of routines stored in a computer's read-only memory (ROM) that tests various system components such as RAM, the disk drives, and the keyboard to see if they are properly connected and operating. If problems are found, the POST routines alert the user by displaying a message, often accompanied by a diagnostic numeric value, to the standard output device. If the POST is successful, it passes control to the system's bootstrap loader.
- RAMDAC** RAM digital-to-analog converter. An ASIC responsible for direct interface to 3DRAM. Also provides on-board phase-lock loop (PLL) and clock generator circuitry for the pixel clock.
- RC** Resistive-capacitive.
- RISC** Reset, interrupt, scan, and clock. An ASIC responsible for reset, interrupt, scan, and clock.
- RMA** Removable media assembly. Can include a CD-ROM drive or 4-mm, 8-mm, 2.5-Gbyte, or SLR tape drive; a diskette drive, and any other 3.5-inch device, such as a second diskette drive or a peripheral component interconnect (PCI) device.
- RJ-45 connector** A modular cable connector standard, used with consumer telecommunications equipment.
- RS-232-C standard** An industry standard for serial communications connections. Adopted by the Electronic Industries Association (EIA), this standard defines the characteristics for serial communications between devices.

RS-423 standard	An industry standards for serial communications between devices with transission distances over 50 feet.
SB	Single buffer.
SCSI	Small computer system interface. An industry standard bus used to connect disk and tape devices to a workstation.
SC_UP+	System controller uniprocessor plus. An ASIC that regulates the flow of requests and data throughout the system unit.
STP	Shielded twisted-pair.
SunVTS	A diagnostic application designed to test hardware.
TPE	Twisted-pair Ethernet.
TOD	Time of day. A time-keeping intergrated circuit.
TTL	Transistor-transistor logic.
UART	Universal asynchronous receiver-transmitter. A device that contains both the receiver and transmitter circuits required for asynchronous serial communications.
U2P	UPA-to-PCI. An ASIC that controls the PCI buses. It forms the bridge from the UPA bus to the PCI buses.
UPA	UltraSPARC port architecture. Provides processor-to-memory interconnection.
UPA AB 0	UPA address bus 0. Provides data interface between the UltraSPARC processor and the SYSIO ASIC.
UPA AB 1	UPA address bus 1. Supports slave UPA connection to the expansion slot for graphics capability.
UTP	Unshielded twisted-pair.
VIS	Visual instruction set.
Vrms	Volts root-mean-square.

Index

NUMERICS

- 4-mm tape drive
 - description, C-18
 - removing, 9-6
 - replacing, 9-7
- 8-mm tape drive
 - description, C-18
 - removing, 9-6
 - replacing, 9-7

A

- agency compliance, C-46
- all above output message, 4-24
- ASIC
 - FBC, C-34
 - PCIO, C-6, C-33
 - RISC, C-34
 - SC_UP+, C-32
 - U2P, C-5, C-33
 - UltraBMX, C-33
- attaching wrist strap, 7-4
- audio, 4-23
 - card
 - connector, C-27
 - functional block diagram, C-28
 - connector, B-10
 - line assignment, B-10
 - pin configuration, B-10
 - module
 - removing, 10-16
 - replacing, 10-17
 - output message, 4-23

- automatic negotiation, C-25

B

- baud rate, verifying, 3-4
- built-in speaker, C-40
- bypassing POST, 3-20

C

- CD-ROM drive, C-15
 - failure, 4-3
 - removing, 9-6
 - replacing, 9-7
- chassis foot, 8-18
 - removing, 8-18, 8-20
 - replacing, 8-19, 8-21
- commands, keyboard control, 3-20
- compliance
 - agency, C-46
 - environmental, C-46
- components, system unit, 1-5
- connector
 - audio, B-10
 - keyboard/mouse, B-1
 - MII, B-13
 - parallel port, B-11
 - pin assignments
 - keyboard/mouse, B-2
 - serial port A, B-3
 - serial port B, B-3
 - pin configuration

- audio, B-10
- keyboard/mouse, B-2
- MII, B-13
- parallel port, B-11
- TPE, B-6
- UltraSCSI, B-7
- UPA graphics card, B-16
- serial port A, B-2
- serial port B, B-2
- TPE, B-5
- UPA graphics card, B-15
- cover, side access
 - removing, 7-1, 7-3
 - replacing, 7-5, 7-6
- CPU module
 - removing, 10-2
 - replacing, 10-3

D

- DC switch assembly
 - removing, 8-22
 - replacing, 8-24
- description, product, 1-1
- desktop workstation, Ultra 30 series, 1-2
- diag-level flag setting, 3-2
- diag-level variable
 - set to max, 3-6
 - set to min, 3-12
- diagnostics, OBP on-board, 4-7
- diag-switch? flag setting, 3-2
- DIMM
 - ejection lever, 10-13
 - failure, 4-6
 - installation locations, 10-12
 - physical memory addresses, 4-6
 - removing, 10-13
 - replacing, 10-14
- diskette drive
 - cable assembly
 - removing, 8-12
 - replacing, 8-13
 - functions, C-16
 - removing, 9-7
 - replacing, 9-7
 - signals, C-16
- diskette port, C-19, C-20
- diskette port functional block diagram, C-19

document organization, xix

E

- EBus
 - DMA register, 4-17
 - DMA register output message, 4-17
 - TCR register, 4-17
 - TCR register output message, 4-17
- electrical specifications, A-2
- EMI filler panel
 - removing, 8-17
 - replacing, 8-18
- enclosure
 - basics, C-45
 - features, C-46
- environmental
 - compliance, C-46
 - requirements, A-2
- error reporting, POST, 3-18
- Ethernet, 4-17, C-24
 - automatic negotiation, C-25
 - connectors, C-25
 - external cables, C-25
 - MII port timing, C-26
 - MII power, C-26
 - output message, 4-18
 - transceivers, external, C-25
- external
 - cables
 - Ethernet, C-25
 - SCSI, C-30
 - Ethernet transceivers, C-25

F

- failure
 - CD-ROM drive, 4-3
 - DIMM, 4-6
 - hard drive, 4-3
 - power-on, 4-1
 - video output, 4-2
- FBC ASIC, C-34
- flag setting
 - diag-level, 3-2
 - diag-switch?, 3-2
- Flash PROM

- jumper settings, C-45
- jumpers, C-45
- floppy
 - diagnostic, 4-19
 - output message, 4-20
- foot, chassis, 8-18
- front view, system unit, 1-3
- functional block diagram
 - audio card, C-28
 - diskette port, C-19
 - keyboard and mouse port, C-19
 - memory module, C-9, C-10
 - memory system, C-8
 - parallel port, C-19
 - SCSI subassembly, C-31
 - serial port, C-22
 - system unit, C-3
 - system unit motherboard, C-42
- UPA
 - address bus, C-5
 - data bus, C-5

G

- graphics card
 - features, C-13
 - performance, C-14

H

- hard drive
 - failure, 4-3
 - removing, 9-1
 - replacing, 9-3
 - supported, C-18
- host adapter, C-29
- how this book is organized, xix

I

- I/O devices, 1-2
- identification assignments, UPA port, C-4
- identifying jumper pins, 10-24, C-43
- illustrated parts list, 11-1
- initializing POST, 3-4
- installation locations, DIMM, 10-12

- internal
 - drives identification, 4-3
 - SCSI sub-assembly, C-30

J

- jumper
 - Flash PROM, C-45
 - pins, identifying, C-43
 - serial port, C-44
 - settings, selected, C-43

K

- keyboard, 4-18
 - LED patterns, 3-19
 - output message, 4-19
 - Sun Type-5, 6-2
- keyboard and mouse port functional block diagram, C-19
- keyboard/mouse
 - connector, B-1
 - pin assignments, B-2
 - pin configuration, B-2
 - port, C-19

L

- LEDs, 3-5
 - keyboard, 3-20
 - patterns, keyboard, 3-19
 - system, 3-20
- line assignment, audio connector, B-10
- lock block location, 7-2

M

- major subassemblies, 8-1
- maximum level of POST, 3-5
- memory
 - module functional block diagram, C-9, C-10
 - system, C-7
 - functional block diagram, C-8
 - timing, C-13
- menu, OBDiag, 4-14
- microphone, C-41

MII

- connector, B-13
 - pin assignments, B-13
 - pin configuration, B-13
- port timing, C-26
 - model, C-26
- power, C-26
- minimum level of POST, 3-5
- motherboard
 - component replacement, 10-1
 - removing, 10-19
 - replacement, 10-1
 - replacing, 10-22
 - test, 3-21
- mouse, 4-19
- mouse output message, 4-19

N

- NVRAM, 4-22
- NVRAM output message, 4-22
- NVRAM/TOD
 - removing, 10-4
 - replacing, 10-5

O

- OBDDiag
 - audio, 4-23
 - EBus DMA register, 4-17
 - EBus TCR register, 4-17
 - Ethernet, 4-17
 - floppy, 4-19
 - keyboard, 4-18
 - menu, 4-14
 - mouse, 4-19
 - NVRAM, 4-22
 - parallel port, 4-20
 - pci/pcio, 4-16
 - SCSI, 4-23
 - serial port A, 4-20
 - serial port B, 4-21
- OBDDiags, 4-12
- OBP on-board diagnostics, 4-7
 - probe-SCSI, 4-9
 - probe-SCSI-all, 4-9
 - selected tests, 4-10

- watch-clock, 4-7
- watch-net, 4-8
- watch-net-all, 4-8
- on/off functionality, C-36
- one-piece shroud assembly
 - removing, 8-26
 - replacing, 8-27
- OpenBoot diagnostics, 4-12
- operation, SunVTS, 2-2
- optional tape drive
 - 4-mm, C-18
 - 8-mm, C-18
- output message
 - all above, 4-24
 - audio, 4-23
 - EBus DMA register, 4-17
 - EBus TCR register, 4-17
 - Ethernet, 4-18
 - floppy, 4-20
 - keyboard, 4-19
 - mouse, 4-19
 - NVRAM, 4-22
 - parallel port, 4-20
 - pci/pcio, 4-16
 - probe-scsi, 4-9
 - probe-scsi-all, 4-9
 - scsi, 4-23
 - serial port A, 4-21
 - serial port A with TIP line, 4-21
 - serial port B, 4-22
 - test, 4-10
 - watch-clock, 4-7
 - watch-net, 4-8
 - watch-net-all, 4-8
- overview
 - I/O devices, 1-2
 - POST, 3-1
 - SunVTS, 2-1

P

- parallel port, 4-20, C-19, C-20
 - cables, C-21
 - connector, B-11
 - pin assignments, B-11
 - pin configuration, B-11
 - electrical characteristics, C-21
 - functional block diagram, C-19

- output message, 4-20
- parts list, illustrated, 11-1
- PCI
 - card
 - removing, 10-6
 - replacing, 10-8
 - fan assembly
 - removing, 8-5, 8-6
 - replacing, 8-7
- pci/pcio, 4-16
- pci/pcio output message, 4-16
- PCIO ASIC, C-6, C-33
- peripheral
 - component interconnect bus, C-5
 - power cable assembly
 - removing, 8-10
 - replacing, 8-11
- peripherals
 - CD-ROM drive, C-15
 - tape drive
 - 4-mm, C-18
 - 8-mm, C-18
- physical specifications, A-1
- pin assignments
 - J2901 connector, 4-5
 - J2902 connector, 4-5
 - J2903 connector, 4-6
 - MII connector, B-13
 - parallel port connector, B-11
 - TPE connector, B-6
 - UltraSCSI connector, B-7
 - UPA graphics card connector, B-16
- POST
 - bypassing, 3-20
 - error reporting, 3-18
 - initializing, 3-4
 - maximum level, 3-5
 - minimum level, 3-5
 - overview, 3-1
 - progress reporting, 3-18
- power estimate
 - 3.3-ns CPU module, C-37
 - 3.3-Vdc PCI card, C-39
 - 4-ns CPU module, C-38
 - 5-Vdc PCI card, C-38
 - memory subsystem, C-39
 - storage devices, C-39
- power supply
 - connector J2901, 4-5

- connector J2902, 4-5
- connector J2903, 4-6
- control signals, C-36
- on/off functionality, C-36
- remote enable
 - PowerOff, C-36
 - PowerOn, C-36
- removing, 8-2
- replacing, 8-4
- test, 4-4
- power supply connector
 - J2901 pin assignments, 4-5
 - J2902 pin assignments, 4-5
 - J2903 pin assignments, 4-6
- powering
 - off system unit, 6-3
 - on system unit, 6-1
- power-on
 - failure, 4-1
 - self-test, 3-1
- pre-POST preparation, 3-2
 - setting up tip connection, 3-2
 - verifying baud rate, 3-4
- probe-SCSI, 4-9
- probe-scsi output message, 4-9
- probe-SCSI-all, 4-9
- probe-scsi-all output message, 4-9
- procedures, troubleshooting, 4-1
- product
 - description, system unit features, 1-3
 - specifications, A-1
- product description, 1-1
- progress reporting, POST, 3-18

R

- rear view, system unit, 1-4
- removing
 - 4-mm tape drive, 9-6
 - 8-mm tape drive, 9-6
 - audio module, 10-16
 - CD-ROM drive, 9-6
 - chassis foot, 8-18, 8-20
 - CPU module, 10-2
 - DC switch assembly, 8-22
 - DIMM, 10-13
 - diskette drive, 9-7
 - diskette drive cable assembly, 8-12

- EMI filler panel, 8-17
- hard drive, 9-1, 9-3
- motherboard, 10-19
- NVRAM/TOD, 10-4
- one-piece shroud assembly, 8-26
- PCI card, 10-6
- PCI fan assembly, 8-5, 8-6
- peripheral power cable assembly, 8-10
- power supply, 8-2
- RMA, 9-4
- SCSI drive bay, 8-7
- side access cover, 7-1, 7-3
- two-piece shroud assembly, 8-28
- two-piece shroud fan assembly, 8-31
- UPA graphics card, 10-9
- UPA graphics card cable assembly, 8-13
- replaceable components
 - system unit, 11-3
- replacing
 - 4-mm tape drive, 9-7
 - 8-mm tape drive, 9-7
 - audio module, 10-17
 - CD-ROM drive, 9-7
 - chassis foot, 8-19, 8-21
 - CPU module, 10-3
 - DC switch assembly, 8-24
 - DIMM, 10-14
 - diskette drive, 9-7
 - diskette drive cable assembly, 8-13
 - EMI filler panel, 8-18
 - hard drive, 9-3
 - motherboard, 10-22
 - NVRAM/TOD, 10-5
 - one-piece shroud assembly, 8-27
 - PCI card, 10-8
 - PCI fan assembly, 8-7
 - peripheral power cable assembly, 8-11
 - power supply, 8-4
 - RMA, 9-8
 - SCSI drive bay, 8-9
 - side access cover, 7-5, 7-6
 - two-piece shroud assembly, 8-30
 - two-piece shroud fan assembly, 8-32
 - UPA graphics card, 10-11
 - UPA graphics card cable assembly, 8-16
- requirements, environmental, A-2
- reset verification, 4-13
- RISC ASIC, C-34
- RMA

- removing, 9-4
- replacing, 9-8

S

- safety requirements, 5-1
- SC_UP+ ASIC, C-32
- SCSI, 4-23, C-28
 - drive bay
 - removing, 8-7
 - replacing, 8-9
 - external cables, C-30
 - host adapter, C-29
 - internal SCSI sub-assembly, C-30
 - subassembly functional block diagram, C-31
 - supported target devices, C-30
- scsi output message, 4-23
- selected jumper settings, C-43
- serial
 - port
 - cable length, C-23
 - port A
 - output message with TIP line, 4-21
 - serial port, C-21
 - asynchronous rates, C-23
 - components, C-21
 - EIA levels, C-23
 - functional block diagram, C-22
 - functions, C-22
 - jumper settings, C-44
 - jumpers, C-44
 - slew rate, C-23
 - synchronous rates, C-23
 - serial port A
 - connector, B-2
 - connector pin assignments, B-3
 - output message, 4-21
 - serial port B
 - connector, B-2
 - connector pin assignments, B-3
 - output message, 4-22
 - setting up tip connection, 3-2
 - shell prompts, xxi
 - signal descriptions, B-1
 - speaker, built-in, C-40
 - specifications
 - electrical, A-2
 - physical, A-1

- product, A-1
- standard system facilities, C-41
- storage devices, 9-1
- Sun
 - Type-5 keyboard, 3-5, 6-2
 - Type-5 keyboard LEDs, 3-5
- SunVTS
 - description, 2-1
 - documentation, 2-2
 - operation, 2-2
 - overview, 2-1
- SuperIO, C-34
- supported
 - hard drives, C-18
 - target devices, C-30
- symbios SCSI controller, C-6
- symbols, 5-1
- system
 - facilities, standard, C-41
 - power off (front panel), 6-4
 - power on (front panel), 6-2
- system unit, C-1
 - components, 1-5
 - exploded view, 11-3
 - features, 1-3
 - front view, 1-3
 - functional block diagram, C-3
 - motherboard functional block diagram, C-42
 - power budget, C-37
 - CPU modules, C-37
 - mass storage devices, C-39
 - memory system, C-39
 - PCI cards, C-38
 - rear view, 1-4
 - replaceable components, 11-3

T

- tape drive
 - 4-mm, C-18
 - 8-mm, C-18
- test
 - motherboard, 3-21
 - power supply, 4-4
- test output message, 4-10
- tip connection, setting up, 3-2
- tools required, 5-3
- TPE connector, B-5, B-6

- pin assignments, B-6
- troubleshooting procedures, 4-1
- two-piece shroud
 - assembly
 - removing, 8-28
 - replacing, 8-30
 - fan
 - removing, 8-31
 - replacing, 8-32
- typical error code failure message, 3-18
- typographic conventions, xxi

U

- U2P ASIC, C-5, C-33
- Ultra 30
 - electrical specifications, A-2
 - environmental requirements, A-2
 - physical specifications, A-1
 - series desktop workstation, 1-2
- UltraBMX ASIC, C-33
- UltraSCSI connector
 - pin assignments, B-7
 - pin configuration, B-7
- UltraSPARC II processor, C-6
- UNIX commands, xx
- UPA, C-4
 - address bus functional block diagram, C-5
 - data bus functional block diagram, C-5
 - port identification assignments, C-4
- UPA graphics card, 4-11
 - cable assembly
 - removing, 8-13
 - replacing, 8-16
 - connector, B-15
 - pin assignments, B-16
 - pin configuration, B-16
 - removing, 10-9
 - replacing, 10-11

V

- verifying baud rate, 3-4
- video output failure, 4-2

W

watch-clock, 4-7

watch-clock output message, 4-7

watch-net, 4-8

watch-net output message, 4-8

watch-net-all, 4-8

watch-net-all output message, 4-8

wrist strap, attaching, 7-4