



# Sun Fire™ V445 Server Installation Guide

---

Sun Microsystems, Inc.  
www.sun.com

Part No. 819-3743-11  
November 2006, Revision A

Submit comments about this document at: <http://www.sun.com/hwdocs/feedback>

Copyright 2006 Sun Microsystems, Inc., 4150 Network Circle, Santa Clara, California 95054, U.S.A. All rights reserved.

Sun Microsystems, Inc. has intellectual property rights relating to technology that is described in this document. In particular, and without limitation, these intellectual property rights may include one or more of the U.S. patents listed at <http://www.sun.com/patents> and one or more additional patents or pending patent applications in the U.S. and in other countries.

This document and the product to which it pertains are distributed under licenses restricting their use, copying, distribution, and decompilation. No part of the product or of this document may be reproduced in any form by any means without prior written authorization of Sun and its licensors, if any.

Third-party software, including font technology, is copyrighted and licensed from Sun suppliers.

Parts of the product may be derived from Berkeley BSD systems, licensed from the University of California. UNIX is a registered trademark in the U.S. and in other countries, exclusively licensed through X/Open Company, Ltd.

Sun, Sun Microsystems, the Sun logo, Java, docs.sun.com, Sun StorEdge, Sun Fire, and Solaris are trademarks or registered trademarks of Sun Microsystems, Inc. in the U.S. and in other countries.

All SPARC trademarks are used under license and are trademarks or registered trademarks of SPARC International, Inc. in the U.S. and in other countries. Products bearing SPARC trademarks are based upon an architecture developed by Sun Microsystems, Inc.

The OPEN LOOK and Sun™ Graphical User Interface was developed by Sun Microsystems, Inc. for its users and licensees. Sun acknowledges the pioneering efforts of Xerox in researching and developing the concept of visual or graphical user interfaces for the computer industry. Sun holds a non-exclusive license from Xerox to the Xerox Graphical User Interface, which license also covers Sun's licensees who implement OPEN LOOK GUIs and otherwise comply with Sun's written license agreements.

U.S. Government Rights—Commercial use. Government users are subject to the Sun Microsystems, Inc. standard license agreement and applicable provisions of the FAR and its supplements.

DOCUMENTATION IS PROVIDED "AS IS" AND ALL EXPRESS OR IMPLIED CONDITIONS, REPRESENTATIONS AND WARRANTIES, INCLUDING ANY IMPLIED WARRANTY OF MERCHANTABILITY, FITNESS FOR A PARTICULAR PURPOSE OR NON-INFRINGEMENT, ARE DISCLAIMED, EXCEPT TO THE EXTENT THAT SUCH DISCLAIMERS ARE HELD TO BE LEGALLY INVALID.

---

Copyright 2006 Sun Microsystems, Inc., 4150 Network Circle, Santa Clara, Californie 95054, États-Unis. Tous droits réservés.

Sun Microsystems, Inc. possède les droits de propriété intellectuelle relatifs à la technologie décrite dans ce document. En particulier, et sans limitation, ces droits de propriété intellectuelle peuvent inclure un ou plusieurs des brevets américains listés sur le site <http://www.sun.com/patents>, un ou les plusieurs brevets supplémentaires ainsi que les demandes de brevet en attente aux États-Unis et dans d'autres pays.

Ce document et le produit auquel il se rapporte sont protégés par un copyright et distribués sous licences, celles-ci en restreignent l'utilisation, la copie, la distribution, et la décompilation. Aucune partie de ce produit ou document ne peut être reproduite sous aucune forme, par quelque moyen que ce soit, sans l'autorisation préalable et écrite de Sun et de ses bailleurs de licence, s'il y en a.

Tout logiciel tiers, sa technologie relative aux polices de caractères, comprise, est protégé par un copyright et licencié par des fournisseurs de Sun.

Des parties de ce produit peuvent dériver des systèmes Berkeley BSD licenciés par l'Université de Californie. UNIX est une marque déposée aux États-Unis et dans d'autres pays, licenciée exclusivement par X/Open Company, Ltd.

Sun, Sun Microsystems, le logo Sun, Java, docs.sun.com, Sun StorEdge, Sun Fire, et Solaris sont des marques de fabrique ou des marques déposées de Sun Microsystems, Inc. aux États-Unis et dans d'autres pays.

Toutes les marques SPARC sont utilisées sous licence et sont des marques de fabrique ou des marques déposées de SPARC International, Inc. aux États-Unis et dans d'autres pays. Les produits portant les marques SPARC sont basés sur une architecture développée par Sun Microsystems, Inc.

L'interface utilisateur graphique OPEN LOOK et Sun™ a été développée par Sun Microsystems, Inc. pour ses utilisateurs et licenciés. Sun reconnaît les efforts de pionniers de Xerox dans la recherche et le développement du concept des interfaces utilisateur visuelles ou graphiques pour l'industrie informatique. Sun détient une licence non exclusive de Xerox sur l'interface utilisateur graphique Xerox, cette licence couvrant également les licenciés de Sun implémentant les interfaces utilisateur graphiques OPEN LOOK et se conforment en outre aux licences écrites de Sun.

LA DOCUMENTATION EST FOURNIE "EN L'ÉTAT" ET TOUTES AUTRES CONDITIONS, DÉCLARATIONS ET GARANTIES EXPRESSES OU TACITES SONT FORMELLEMENT EXCLUES DANS LA LIMITE DE LA LOI APPLICABLE, Y COMPRIS NOTAMMENT TOUTE GARANTIE IMPLICITE RELATIVE À LA QUALITÉ MARCHANDE, À L'APTITUDE À UNE UTILISATION PARTICULIÈRE OU À L'ABSENCE DE CONTREFAÇON.



# Contents

---

## **Preface** v

- 1. Preparing for Installation** 1
  - About the Parts Shipped to You 1
  - Verifying All Parts 2
  - Accessing Online Documentation 3
  - Planning the Installation 3
  - What Next 4
  
- 2. Installing a Sun Fire V445 Server Into a 4-Post Cabinet** 5
  - Checklist of Rackmounting Tasks 6
  - Taking Inventory for Rackmounting 7
  - Tools Required for Rackmounting 8
  - Attaching the Inner Glides to the Chassis 9
  - Preparing the Cabinet 10
  - Locating the Mounting Holes 11
  - Installing the Slide Assemblies 13
  - Installing the Server Into the Cabinet 17
  - Installing the Cable Management Arm 20
  - Securing the Cords and Cables to the  
Cable Management Arm 22

Installing Optional Components	24
Connecting the Cords and Cables	24
Connecting Twisted-Pair Ethernet Cables	26
Restoring the Cabinet	27
What Next	27
<b>3. Setup and Power-On Procedures</b>	<b>29</b>
IMPORTANT: About Initial Configuration and Power-On	29
About Setting Up a System Console Device	30
About Connecting the Server to a Terminal Server	30
Accessing the System Console through a Terminal Server	32
Accessing the System Console Through an Alphanumeric Terminal	34
Accessing the System Console Through a Tip Connection	36
Preparing to Configure the Primary Network Interface	38
Powering On the Server	39
Powering On Using the Power Button	40
Powering On Remotely Using the poweron Command	42
Installing the Solaris Operating System and Additional Software	44
What Next	45
<b>A. Installation Reference</b>	<b>47</b>
System Indicators	47
System Controller Ports	50
Network Management Port	50
Serial Management Port	51
4-Post Cabinet Requirements	52
<b>Index</b>	<b>55</b>

# Preface

---

The *Sun Fire V445 Server Installation Guide* provides instructions, some background information, and reference material to help you install a new Sun Fire™ V445 server.

Instructions in Chapters 1 and 3 assume that a system administrator who is experienced with the Solaris™ Operating System (Solaris OS) is performing the installation. However, you do not need Solaris OS experience to follow the instructions in Chapter 2, which detail the installation of the Sun Fire V445 server into a 4-post cabinet.

---

## How This Book Is Organized

This guide is organized into three chapters and one appendix.

[Chapter 1](#) illustrates the contents of the Sun Fire V445 server ship kit, provides guidelines for planning the installation, and describes how to access additional documentation on the Sun web site.

[Chapter 2](#) provides instructions for installing the Sun Fire V445 server into a 4-post cabinet, installing the cable management arm, and routing the cables and cords into the cable management arm.

[Chapter 3](#) provides instructions for powering on the server and for installing the Solaris OS and additional software.

[Appendix A](#) includes background information about the system console and additional technical specifications, including specifications for connectors and for the rack.

---

# Using UNIX Commands

This document might not contain information on basic UNIX® commands and procedures such as shutting down the system, booting the system, and configuring devices.

Refer to the following for this information:

- Software documentation that you received with your system
- Solaris™ Operating System documentation, which is at:

<http://docs.sun.com>

---

# Shell Prompts

Shell	Prompt
C shell	<i>machine-name%</i>
C shell superuser	<i>machine-name#</i>
Bourne shell and Korn shell	\$
Bourne shell and Korn shell superuser	#

---

# Typographic Conventions

Typeface*	Meaning	Examples
AaBbCc123	The names of commands, files, and directories; on-screen computer output	Edit your <code>.login</code> file. Use <code>ls -a</code> to list all files. % You have mail.
<b>AaBbCc123</b>	What you type, when contrasted with on-screen computer output	% <b>su</b> Password:
<i>AaBbCc123</i>	Book titles, new words or terms, words to be emphasized. Replace command-line variables with real names or values.	Read Chapter 6 in the <i>User's Guide</i> . These are called <i>class</i> options. To delete a file, type <b>rm</b> <i>filename</i> .

\* The settings on your browser might differ from these settings.

---

## Related Documentation

<b>Application</b>	<b>Title</b>	<b>Part Number</b>
Late-breaking product information	<i>Sun Fire V445 Server Product Notes</i>	819-3744
Cabling and power-on overview	<i>Sun Fire V445 Server Getting Started Guide</i>	819-3041
Administration, diagnostics, and troubleshooting	<i>Sun Fire V445 Server Administration Guide</i>	819-3741
Parts installation and removal	<i>Sun Fire V445 Server Service Manual</i>	819-3742
Sun Advanced Lights Out Manager (ALOM) system controller	<i>Sun Advanced Lights Out Manager (ALOM) 1.6 Online Help</i>	817-1960

---

## Documentation, Support, and Training

<b>Sun Function</b>	<b>URL</b>
Documentation	<a href="http://www.sun.com/documentation/">http://www.sun.com/documentation/</a>
Support	<a href="http://www.sun.com/support/">http://www.sun.com/support/</a>
Training	<a href="http://www.sun.com/training/">http://www.sun.com/training/</a>

---

## Third-Party Web Sites

Sun is not responsible for the availability of third-party web sites mentioned in this document. Sun does not endorse and is not responsible or liable for any content, advertising, products, or other materials that are available on or through such sites or resources. Sun will not be responsible or liable for any actual or alleged damage or loss caused by or in connection with the use of or reliance on any such content, goods, or services that are available on or through such sites or resources.



---

# Sun Welcomes Your Comments

Sun is interested in improving its documentation and welcomes your comments and suggestions. You can submit your comments by going to:

<http://www.sun.com/hwdocs/feedback>

Please include the title and part number of your document with your feedback:

*Sun Fire V445 Server Installation Guide*, part number 819-3743-11.



## Preparing for Installation

---

This chapter includes a description of the components of the Sun Fire V445 server, and a set of questions that the system administrator must answer before installing the server software.

This chapter contains the following sections:

- [“About the Parts Shipped to You” on page 1](#)
- [“Verifying All Parts” on page 2](#)
- [“Accessing Online Documentation” on page 3](#)
- [“Planning the Installation” on page 3](#)
- [“What Next” on page 4](#)

---

## About the Parts Shipped to You

Standard components of Sun Fire V445 servers are installed at the factory. However, if you ordered options such as a PCI card and monitor, these are shipped to you separately.

In addition, you should have received the Solaris Media Kit and documentation for all appropriate system software.

Check that you have received everything you ordered.

---

**Note** – Inspect the shipping carton for evidence of physical damage. If a shipping carton is damaged, request that the carrier’s agent be present when the carton is opened. Keep all contents and packing material for the agent’s inspection.

---

# Verifying All Parts

- Verify that you have received all the parts of your system.

See the illustration below to identify most of the parts shipped with the system.

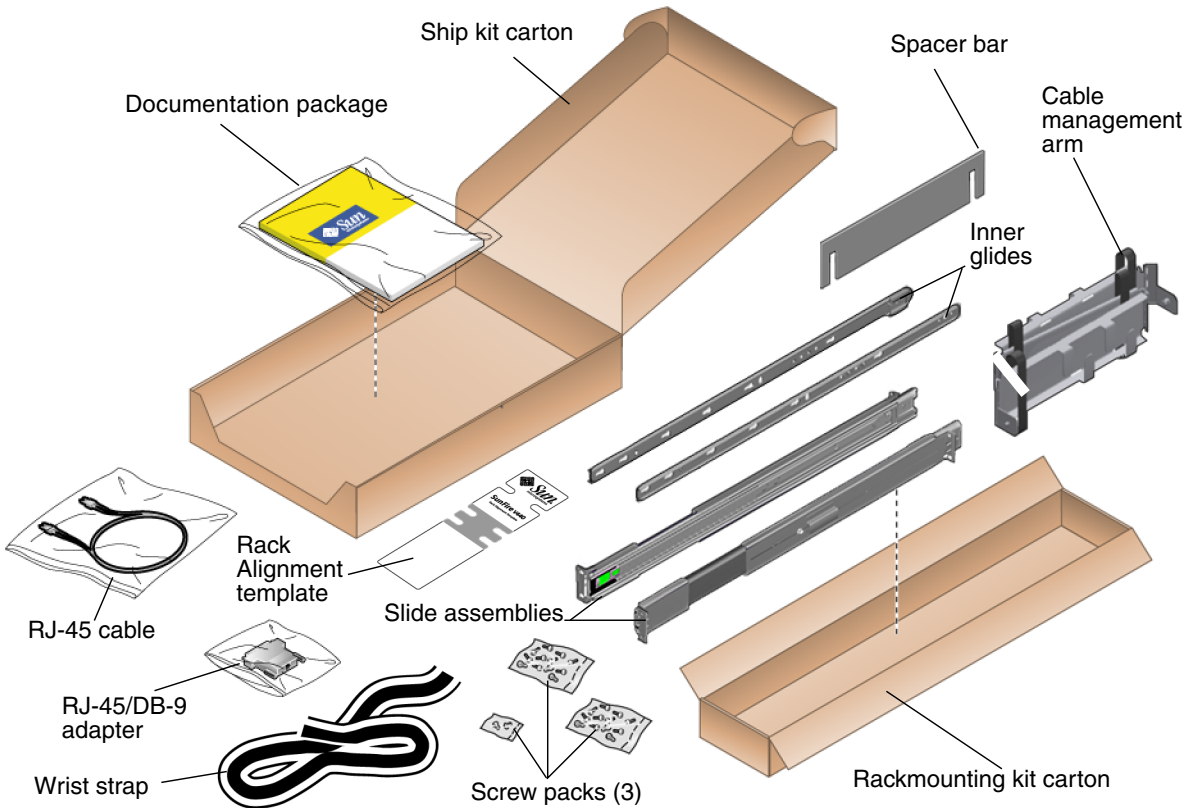


FIGURE 1-1 Contents of ship kit

---

# Accessing Online Documentation

The most up-to-date information for Sun Fire V445 Server is available online at the following URL:

<http://www.sun.com/documentation>

Click through to the Sun Fire V445 documentation from the main documentation web site.

In addition to this guide, the following documents are available on the documentation web site:

- *Sun Fire V445 Server Safety Information*
- *Sun Fire V445 Server Product Notes*
- *Sun Fire V445 Server Administration Guide*
- *Sun Fire V445 Server Diagnostics and Troubleshooting Guide*
- *Sun Fire V445 Server Parts Installation and Removal Guide*
- *Sun Advanced Lights Out Manager (ALOM) 1.6 Online Help*
- *Sun Safety and Compliance Manual*

---

# Planning the Installation

The Sun Fire V445 server is a general-purpose server. How you set up your server depends on what you want it to do.

This set of installation procedures is intended to be as general as possible, to accommodate the variety of uses to which you can apply the server. Even so, you need to make certain decisions to complete the procedures. If you need background information to help you answer the following two questions, see the *Sun Fire V445 Server Administration Guide*.

- On which network or networks do you intend to operate the server?

You need to provide specific networking information about the server when you install the Solaris OS.

- How do you want to use and configure the server's internal disks?
- What software do you intend to load?

Software included in the Solaris Media Kit or other software products can impose certain disk space or disk partitioning requirements. Refer to the documentation accompanying the Solaris software to determine those requirements.

---

**Note** – Be sure to use a supported version of the Solaris OS. See the *Sun Fire V445 Server Product Notes* for more information.

---

---

## What Next

Install the server into a cabinet, following instructions in [Chapter 2](#).

## Installing a Sun Fire V445 Server Into a 4-Post Cabinet

---

This chapter shows you how to install a Sun Fire V445 server into a 4-post Sun™ StorEdge™ Expansion Cabinet or other Electronic Industries Association (EIA)-compliant 19-inch (48.26-cm) wide rack.

---

**Note** – To install a server into an EIA-compliant 19-inch wide rack with mounting holes sized for U.S. dimension screws, use only 10-32 screws to attach the slide assemblies to the rack. The rackmounting kit includes 10-32 and M4 screws. Use the M4 screws to attach the glides to the chassis.

---

---

**Note** – To install a server into an EIA-compliant 19-inch wide rack with mounting holes sized for metric dimension screws, use only M6 screws to attach the slide assemblies to the rack. The rackmounting kit includes M4 and M6 screws. Use the M4 screws to attach the glides to the chassis.

---

This chapter contains the following procedures and information:

- [“Checklist of Rackmounting Tasks” on page 6](#)
- [“Taking Inventory for Rackmounting” on page 7](#)
- [“Tools Required for Rackmounting” on page 8](#)
- [“Attaching the Inner Glides to the Chassis” on page 9](#)
- [“Preparing the Cabinet” on page 10](#)
- [“Locating the Mounting Holes” on page 11](#)
- [“Installing the Slide Assemblies” on page 13](#)
- [“Installing the Server Into the Cabinet” on page 17](#)
- [“Installing the Cable Management Arm” on page 20](#)
- [“Securing the Cords and Cables to the Cable Management Arm” on page 22](#)
- [“Installing Optional Components” on page 24](#)
- [“Connecting the Cords and Cables” on page 24](#)
- [“Connecting Twisted-Pair Ethernet Cables” on page 26](#)

- [“Restoring the Cabinet” on page 27](#)
- [“What Next” on page 27](#)

For a detailed list of 4-post cabinet requirements, see [“4-Post Cabinet Requirements” on page 50](#).

## Checklist of Rackmounting Tasks

**TABLE 2-1** provides a checklist of the tasks need to complete the rackmounting procedure, as well as the relevant sections in this manual.

**TABLE 2-1** Checklist of rackmounting tasks

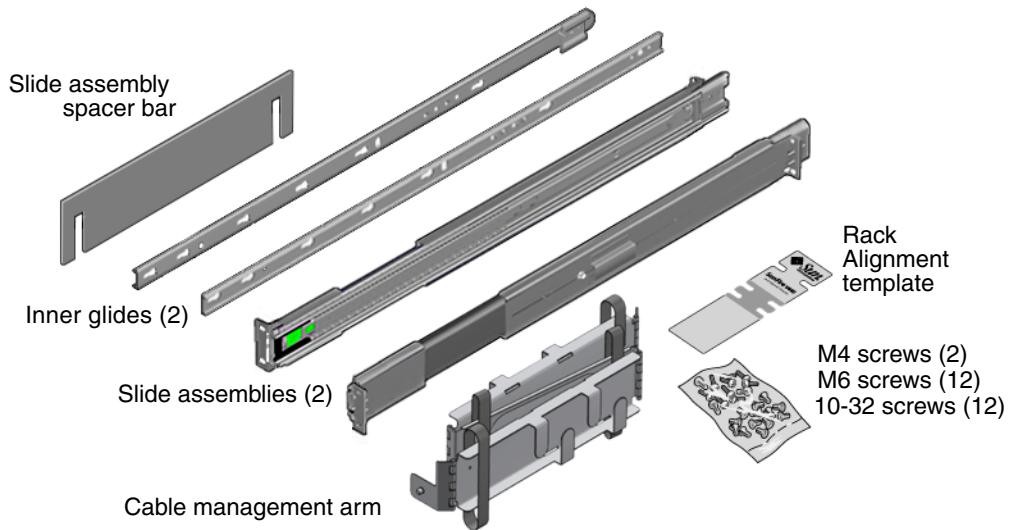
Step	Task	Refer to This Section
1	Install the inner glides on the chassis.	<a href="#">“Attaching the Inner Glides to the Chassis” on page 9</a>
2	Prepare the cabinet.	<a href="#">“Preparing the Cabinet” on page 10</a>
3	Locate the mounting holes.	<a href="#">“Locating the Mounting Holes” on page 11</a>
4	Install the slide assemblies into the cabinet.	<a href="#">“Installing the Slide Assemblies” on page 13</a>
5	Install the server into the cabinet.	<a href="#">“Installing the Server Into the Cabinet” on page 17</a>
6	Install the cable management arm.	<a href="#">“Installing the Cable Management Arm” on page 20</a>
7	Secure the cords and cables to the cable management arm.	<a href="#">“Securing the Cords and Cables to the Cable Management Arm” on page 22</a>
8	Install optional components.	<a href="#">“Installing Optional Components” on page 24</a>
9	Connect the power cords.	<a href="#">“Connecting the Cords and Cables” on page 24</a>
10	Connect a twisted-pair Ethernet (TPE) cable.	<a href="#">“Connecting Twisted-Pair Ethernet Cables” on page 26</a>
11	Restore the cabinet.	<a href="#">“Restoring the Cabinet” on page 27</a>



---

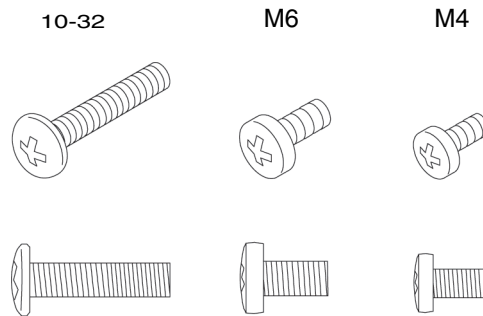
# Taking Inventory for Rackmounting

You need one rackmounting kit for each Sun Fire V445 server you intend to install into a cabinet. The rackmounting kit is included with the server. You also need this document, and the Rack Alignment template from the ship kit.



**FIGURE 2-1** Parts needed for rackmounting the server

The plastic bags of hardware contain screws and nuts that are shown below in actual size.



**FIGURE 2-2** Hardware included with the rackmounting kit

Any screws not used for rackmounting are spares.

---

**Note** – Bar nuts are required (but not included) for nonthreaded cabinets. See the instructions provided with your cabinet for more information.

---

## Tools Required for Rackmounting

- Phillips No. 2 screwdriver (use to tighten 10-32 and M6 screws)
- Set of appropriate Allen wrenches to remove the side panels on some cabinets
- Adjustable wrench to tighten the nuts on the mounting brackets

# Attaching the Inner Glides to the Chassis

1. **Position the straight end of each inner glide toward the front of the server.**

Keyhole-shaped mounting holes in the inner glides fit over a row of studs in each side of the server.

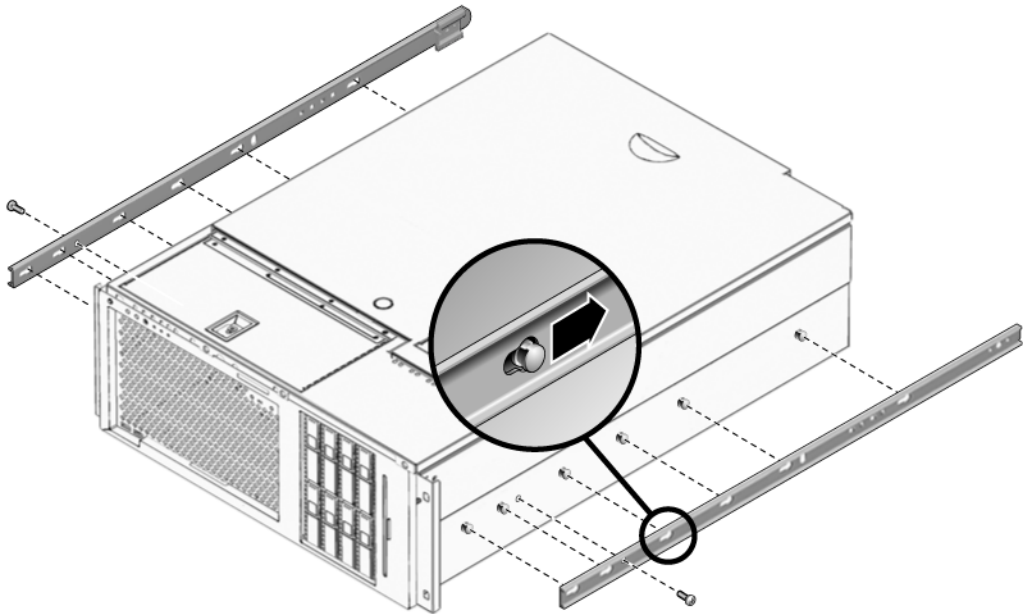
---

**Note** – The inner glide with the cable management arm mounting bracket should be installed on the left (non-power-supply) side of the server.

---

2. **Slide each inner glide back until it is securely fastened to the server.**

One round hole on each inner glide should be aligned with a corresponding threaded mounting point on the server.



**FIGURE 2-3** Attaching the inner glides to the server

3. **Secure each inner glide to the chassis with one M4 screw.**

Install the screw through the round mounting hole on each inner glide.

---

# Preparing the Cabinet

1. **Open and remove, if applicable, the front and back doors of the cabinet.**  
See the instructions provided with your cabinet.
2. **Stabilize the cabinet by extending its antitip legs or bolting the cabinet securely to the floor.**

See the instructions provided with your cabinet and read [“4-Post Cabinet Requirements” on page 50.](#)

FIGURE 2-4 shows two antitip legs. Note that some cabinets have only one such leg.

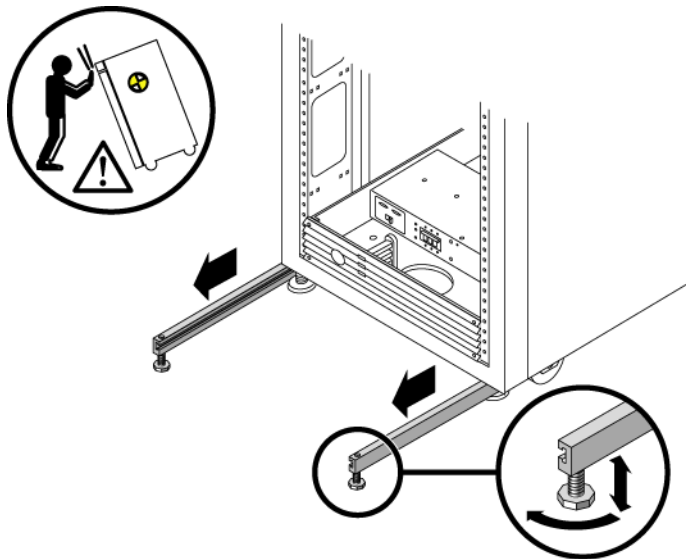


FIGURE 2-4 Extending the antitip legs

3. **Remove the side panels from the cabinet, if applicable.**  
See the instructions provided with your cabinet. Removing the side panels can improve access to the areas where you will install nuts and screws when securing the server in the cabinet.

---

# Locating the Mounting Holes

You can either count the holes on the vertical rack rails or use the rack alignment template included with your documentation set. Ensure that each slide assembly is installed at the same height front-to-back and side-to-side in the rack.

The rack alignment template is four rack units (7.00 inch/17.78 cm) tall. You use the rack alignment template to ensure that the server is correctly placed within standard rack unit spacing, in which the top of the system is defined to be midway between a set of holes separated by 0.5 inch (1.27 cm).

The 4-post mounting holes on the rack alignment template are for mounting the slide assembly brackets to the vertical rack rails. The upper and lower retainer screw openings in the template locate the chassis bracket screws that secure the server in the rack after the server is installed.

FIGURE 2-5 shows the Rack Alignment template.

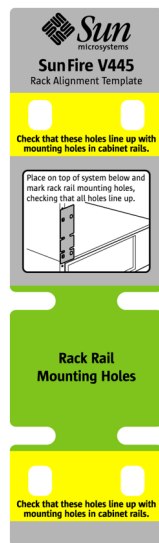
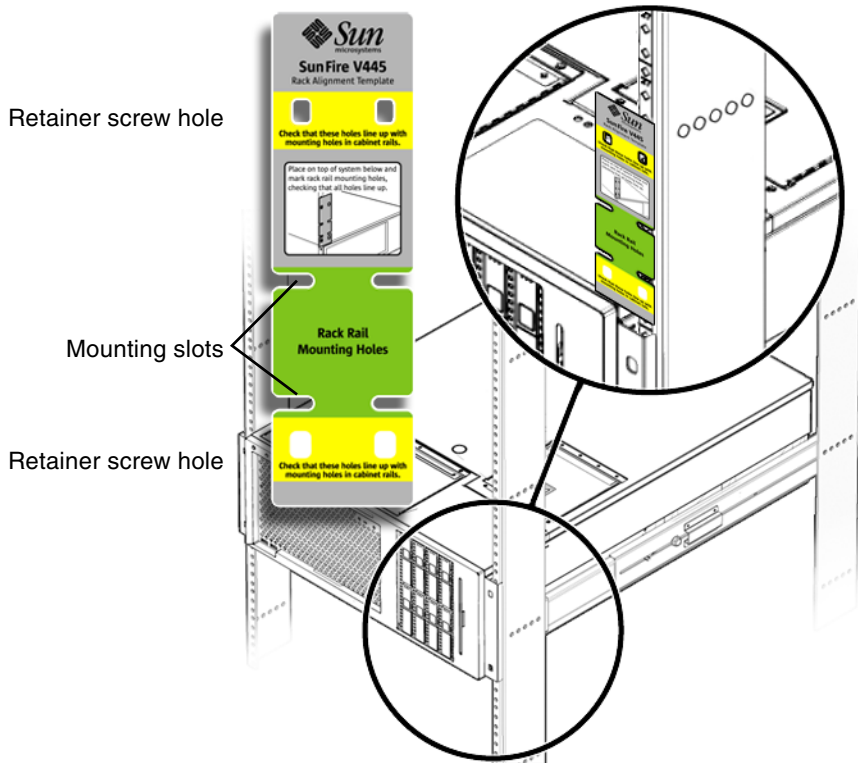


FIGURE 2-5 Rack alignment template

To use the rack alignment template, complete these steps:

1. Place the rack alignment template over the right front vertical rack rail, then move the bottom of the template to the location on the rack rail where the bottom of the server will be located.



**FIGURE 2-6** Using the rack alignment template

2. Adjust the rack alignment template until the mounting slot openings are centered on two holes in the rail and the retainer screw hole is visible.

When you do this, the top of the template is midway between a set of half-inch holes.

3. Repeat [Step 1](#) and [Step 2](#) for the left front vertical rack rail.

---

# Installing the Slide Assemblies

Be aware of the following guidelines.



---

**Caution** – Ensure that you have stabilized the cabinet by extending its antitip legs or bolting the cabinet securely to the floor.

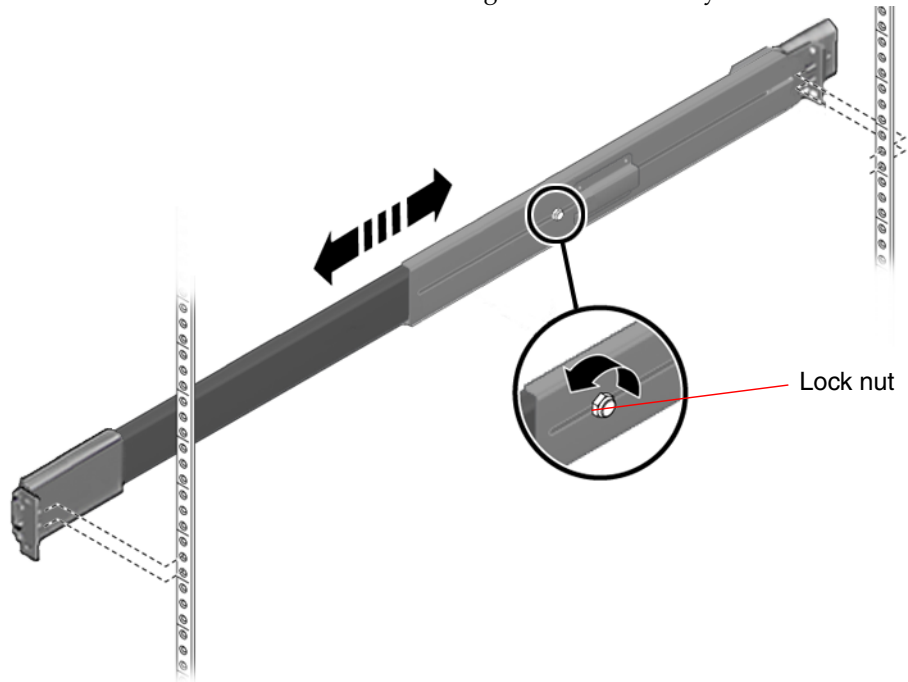
---

- Install the slide assemblies into the lowest available position.
  - Install additional servers from the base up in the cabinet.
1. Use the rack alignment template to locate and mark mounting holes on the front and rear vertical rack rails.

See “Locating the Mounting Holes” on page 11.

2. Adjust the back mounting brackets to accommodate the depth of the cabinet.

Loosen the 8-32 lock nut on each of the back mounting brackets, until the mounting brackets can move forward or rearward along the slide assembly.



**FIGURE 2-7** Adjusting the slide assembly to the depth of the cabinet

---

**Note** – Slide assemblies are labeled “LEFT” and “RIGHT”. Install them to the appropriate side when facing the *front* of the cabinet.

---

3. **With the help of an assistant, position one slide assembly on the inside of the cabinet with the front (short) mounting bracket at the front of the rack.**
  - a. Use the holes you marked in [Step 1](#).
  - b. Ensure that the slide assembly is level front-to-back.
  - c. Use the mounting pins on the brackets to help position the slide assemblies during installation.



---

**Caution** – Do not attempt to install the server before securing the slide assemblies in the cabinet with the hardware provided.

---

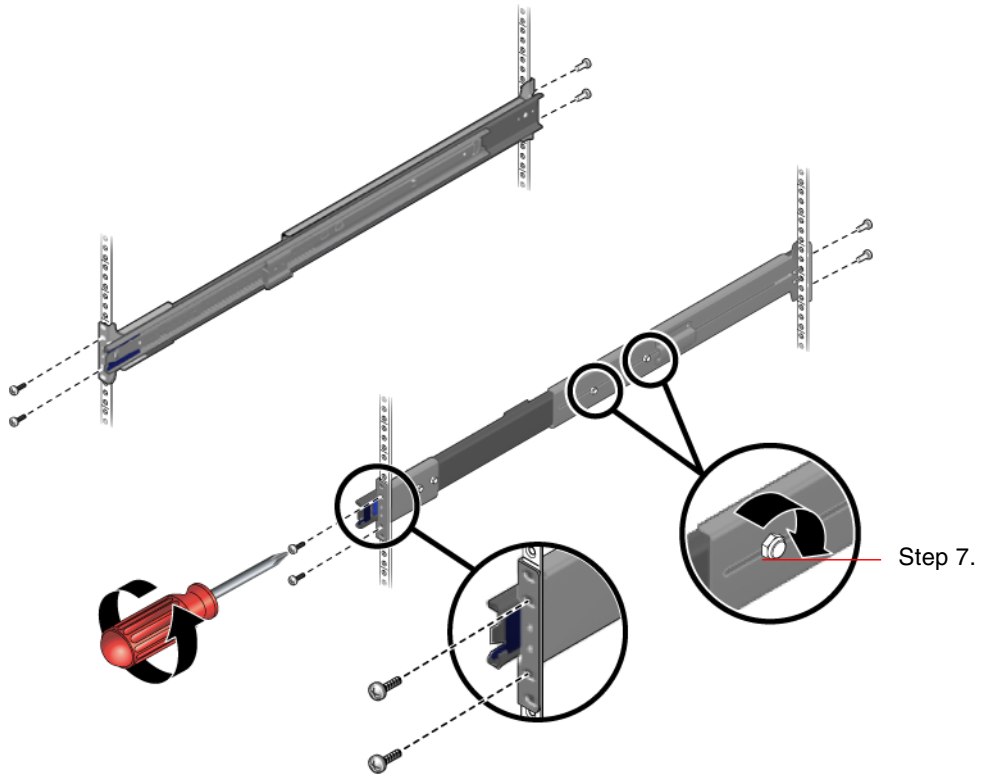
4. **Using two screws for each bracket, attach the front mounting bracket to the front rail of the cabinet and attach the back (long) mounting bracket to the back rail of the cabinet.**

Count the rack rail holes to ensure that you are matching the holes used on the front rail.

To attach the slide assembly, use the appropriate screws for your type of rack:

- Racks with mounting holes sized for U.S. dimensions require 10-32 screws.
- Racks with mounting holes sized for metric dimensions require M6 screws.

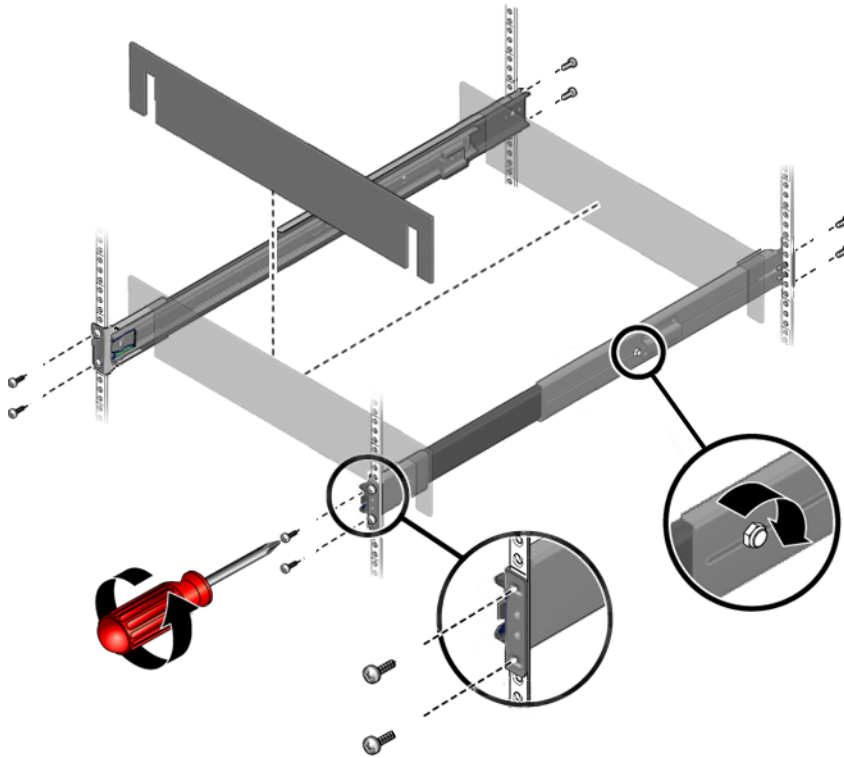




**FIGURE 2-8** Attaching the slide assemblies to the rack rails

5. *Partially* tighten the front and rear bracket screws.

**6. Use the spacer bar to align the rack rails.**



**a. Place the spacer bar over the rack rails near the front of the cabinet.**

Make sure the spacer bar is placed over the mounting flanges, as close as possible to the front cabinet rails.

**b. Fully tighten the front bracket screws.**

**c. Place the spacer bar over the rack rails near the rear of the cabinet.**

Make sure the spacer bar is placed over the mounting flanges, as close as possible to the rear cabinet rails.

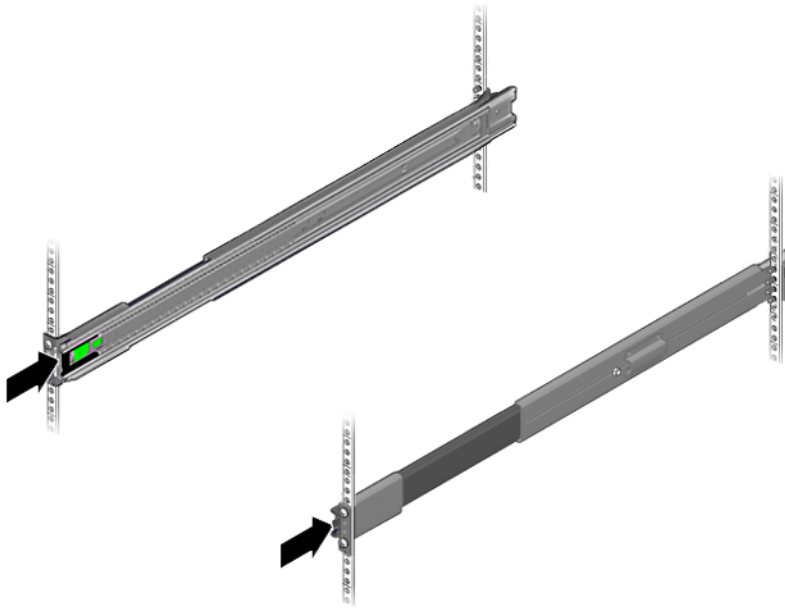
**d. Fully tighten the rear bracket screws.**

**7. If possible, fully tighten the 8-32 lock nuts on the back mounting bracket.**

The nuts use a 3/8 in. driver.

8. Ensure that each slide assembly is fully retracted into the cabinet, and that the ball bearing cages are all the way forward.

The ball bearing cages are locked into the correct position along the inner glides.



**FIGURE 2-9** Ensuring the inner glides are locked into position

---

**Note** – Release the spring catch to push the inner slides into the cabinet.

---

---

## Installing the Server Into the Cabinet

---



**Caution** – Before you install or remove the server from the cabinet, ensure that the cabinet is stabilized so that it cannot move or tip forward. See the cabinet documentation for information about stabilizing the cabinet.

---



---

**Caution** – The server is heavy. Two people are required to move the server.

---

**Note** – Ensure that each slide assembly is fully retracted into the cabinet and check that the ball-bearing runner on each slide assembly is all the way forward.

---

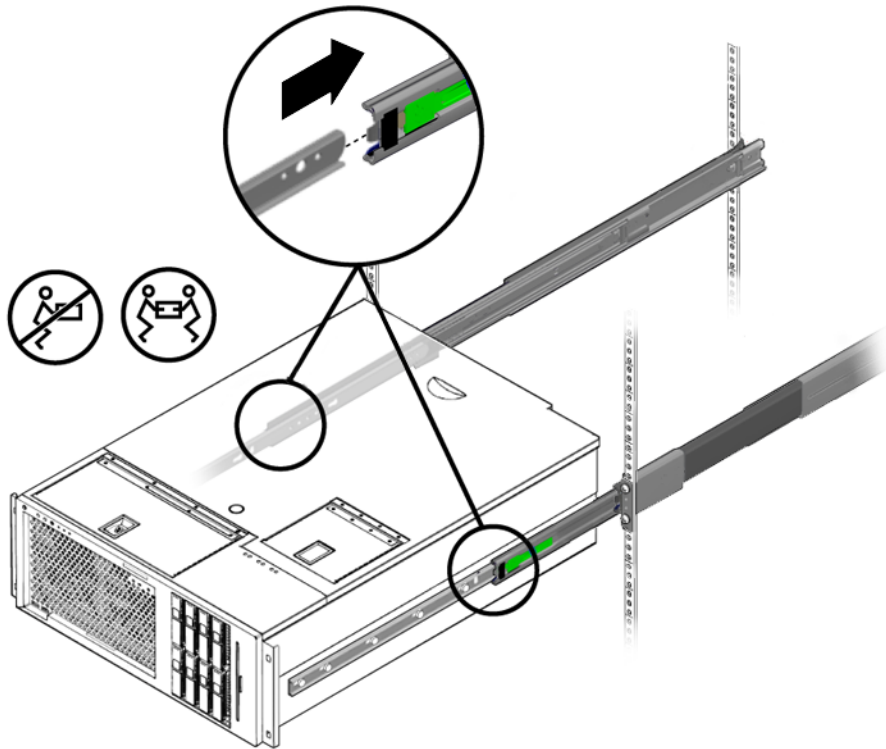
1. With one person on each side of the server, lift the server and approach the cabinet with the back of the server facing the front of the cabinet.
2. Align the rounded ends of the inner glides on the server with the slide assemblies in the cabinet.

---

**Note** – Ensure that the inner glides attached to the server are inserted within the ball-bearing runners.

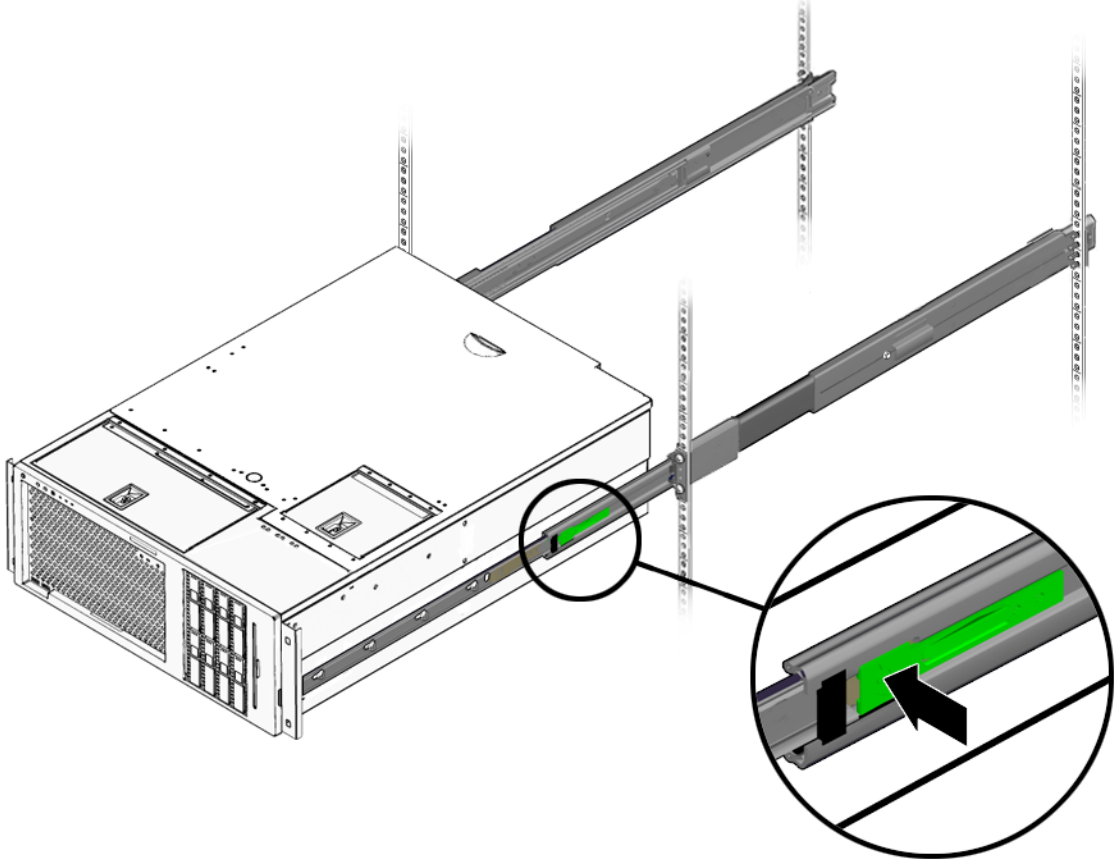
---

3. Holding the server level, slide it evenly into the ends of the slide assemblies until the inner glides stop.



**FIGURE 2-10** Sliding the server into the cabinet

4. Press the green release tabs on both sides of the server to slide the server all the way into the cabinet.



---

**Tip** – Slide the server in and out of the cabinet slowly and carefully to ensure that the slide assemblies are working correctly and are free from obstructions.

---

5. If you are *not* installing the cable management arm, secure the server to the front vertical mounting rails now using either four M6 screws or four 10-32 screws, as described in [FIGURE 2-14](#).

---

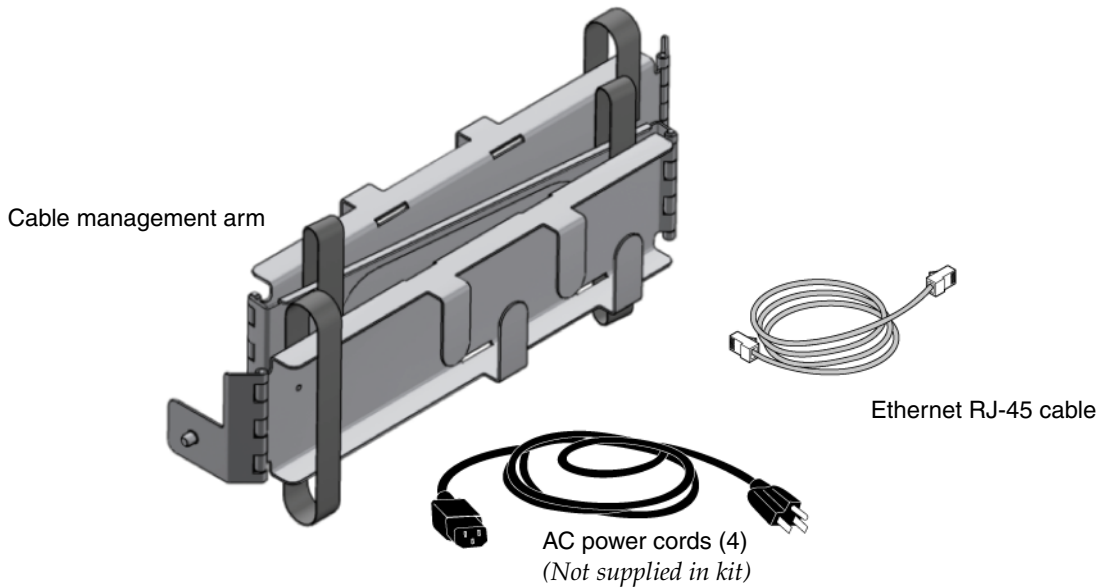
# Installing the Cable Management Arm

This procedure describes how to attach the cable management arm to a server that is already installed in a cabinet.

You need the following components from the ship kit and the rackmounting kit to install the cable management arm and to connect the cords and cables:

- Cable management arm
- Ethernet (RJ-45) cable

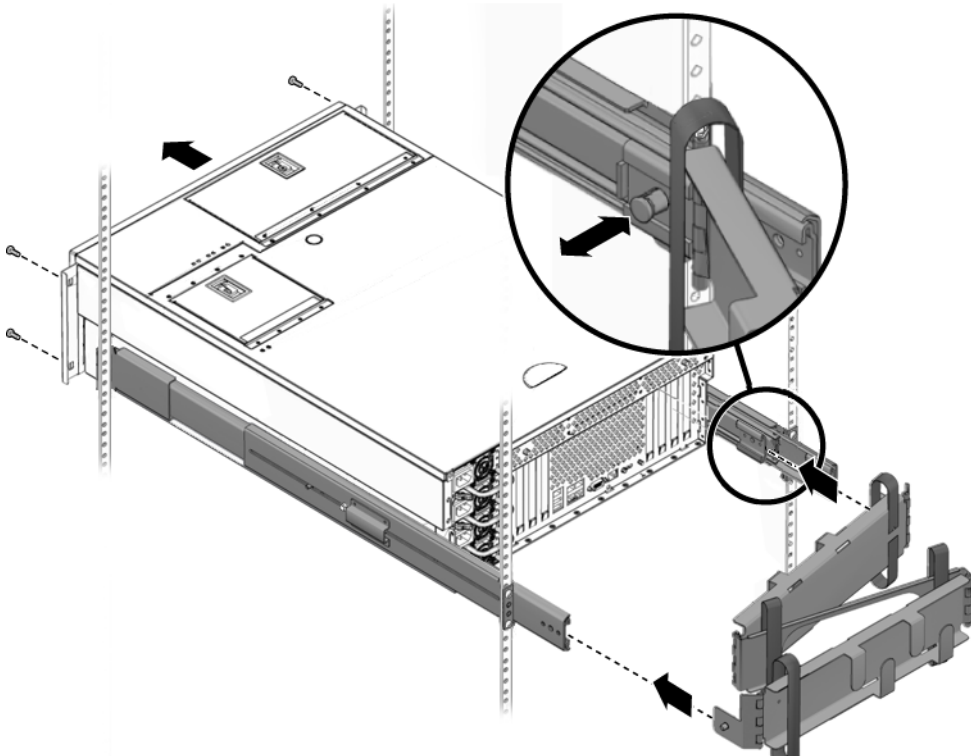
You also need four AC power cords, which are supplied separately.



**FIGURE 2-11** Cable management arm and system cables

- 1. Loosen the four screws that secure the system to the left and right vertical rails at the front of the cabinet.**
- 2. Slide the server smoothly out of the cabinet about 3 inches (7.62 cm).**  
Sliding the server out of the cabinet enables easy access to the areas where you will attach the cable management arm.

3. Go to the back of the cabinet and use the following instructions to attach the left end of the cable management arm to the left inner glide.



**FIGURE 2-12** Attaching the cable management arm

- a. At the back of the cabinet, locate the mounting slot at the end of the inner glide *opposite* the power supplies.
  - b. Position the cable management arm so that the hinged tab slides into the end of the inner glide.
  - c. Slide the hinged tab in until its locking pin snaps into place.
4. Attach the other end of the cable management arm to the slide assembly.
    - a. Locate the end of the slide assembly.
    - b. Position the cable management arm so that the hinged tab slides into the end of the slide assembly.
    - c. Slide the hinged tab in until its locking pin snaps into place.

---

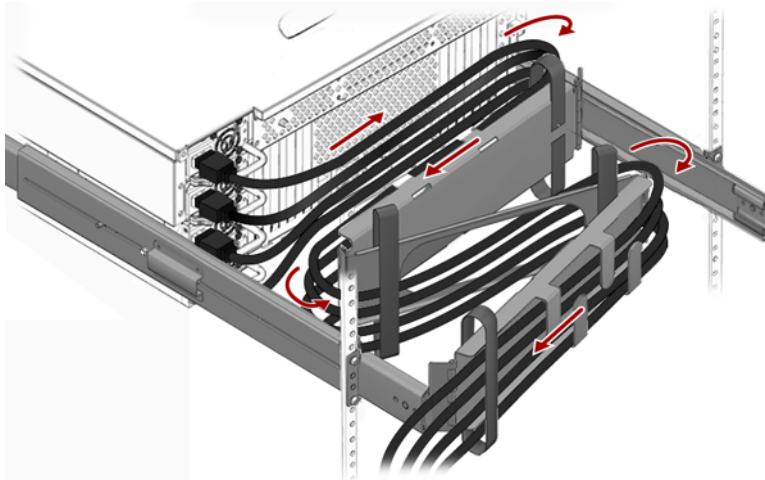
# Securing the Cords and Cables to the Cable Management Arm

---

**Note** – This procedure illustrates how to secure the power cords and the Ethernet cable to the cable management arm. Your server might use additional cables.

---

1. **If necessary, slide the chassis smoothly out of the cabinet about 3 inches (8 cm).**  
Sliding the server out of the cabinet provides easier access to the cable management arm.
2. **Locate the metal fingers on the first and third sections of the cable management arm.**
3. **Locate the center section of the cable management arm.**  
The Velcro straps enable you to route the cables and cords and secure them to the cable management arm.
4. **Route the cables into the fingers in the first section of the cable management arm.**  
Leave enough slack in the cables to ensure that the hinges operate freely without crimping or binding the cables.



**FIGURE 2-13** Routing cables through the cable management arm



**5. Arrange the cables along the center section of the cable management arm.**

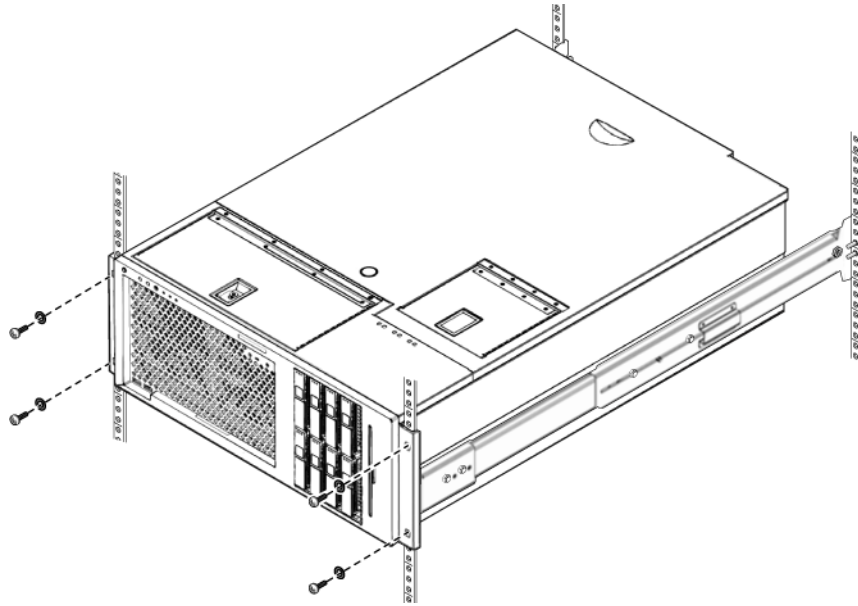
Distribute the cables evenly above and below the center section of the cable management arm, securing them with the Velcro straps. Leave enough slack around the hinges to ensure that they operate freely without crimping or binding the cables.

**6. Route the cables into the fingers in the third section of the cable management arm.**

**7. Plug in the twisted-pair Ethernet (TPE) cable to the RJ-45 outlet to connect to your Ethernet network.**

See your network administrator if you need more information about how to connect to your network.

**8. Secure the server to the front vertical mounting rails using either four M6 screws or four 10-32 screws.**



**FIGURE 2-14** Securing the front of the server to the cabinet

---

# Installing Optional Components

- **Install any optional components shipped with your system.**

If you ordered options that are not factory-installed, see the *Sun Fire V445 Server Service Manual* for installation instructions.

---

**Note** – All internal components except disk drives, DVD drive, power supplies, fan trays, and PCI cards must be installed by qualified service technicians only.

---



---

**Caution** – Place components on an antistatic surface, such as a Sun antistatic discharge mat, an antistatic bag, or a disposable antistatic mat, to protect electronic components from electrostatic damage.

---



---

**Caution** – Always wear an antistatic wrist strap connected to a metal surface on the chassis when you work on system components.

---

---

# Connecting the Cords and Cables

---

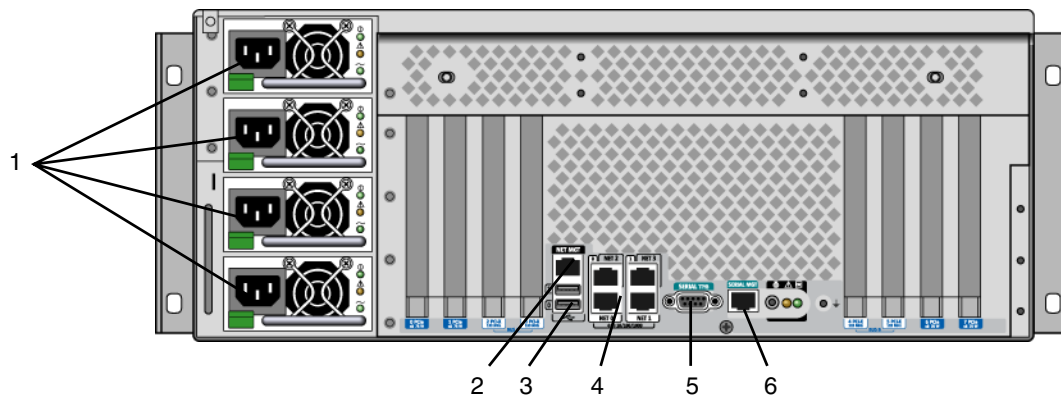
**Note** – Do not connect the system power cords until after you establish a connection to the serial management port. See [Chapter 3](#) for power-on instructions.

---



**Caution** – High leakage current. To prevent leakage current in excess of 3.5 mA, a maximum of two power cords can be connected to a single branch circuit. The remaining two power cords must be connected to a different branch circuit.

The following figure shows the Sun Fire V445 server back panel and identifies the AC power inlets and I/O ports.



**FIGURE 2-15** Back panel cable connections

**TABLE 2-2** Back panel cable connections

Port	Information
1 AC inlets (4)	Power cords connect to each AC inlet. Do <i>not</i> connect the cord to an AC outlet at this point. See <a href="#">“Connecting the Cords and Cables”</a> on page 24.
2 Network management port (NET MGT)	You use this port to access ALOM features by way of the network. <b>Note:</b> You must perform first-time configuration using the serial management port before you can use the network management port.
3 USB ports (2)	See the <i>Sun Fire V445 Server Administration Guide</i> for information about devices you can connect to these ports.

**TABLE 2-2** Back panel cable connections (Continued)

Port	Information
4 Ethernet ports (4)	You use these ports to connect to your Ethernet network. The lower left port is NET0; the lower right port is NET1; the upper left port is NET2; the upper right port is NET3. See <a href="#">“Connecting Twisted-Pair Ethernet Cables”</a> on page 26.
5 DB9 serial port (TTYB)	This is a POSIX-compliant serial port. An adapter is included in the system ship kit in order to connect this port to an RJ-45 cable. See the <i>Sun Fire V445 Server Administration Guide</i> for more information.
6 Serial management port (SER MGT)	This is the default port for accessing ALOM features during initial system startup. Note that the serial management port is not a standard serial port. See the <i>Sun Fire V445 Server Administration Guide</i> for more information.

## Connecting Twisted-Pair Ethernet Cables

Connect a twisted-pair Ethernet (TPE) cable to the Ethernet ports on the back panel. Each network interface is capable of 10-Mbps, 100-Mbps, or 1000-Mbps operation depending on network characteristics.

1. Choose a network port, using [TABLE 2-3](#) as a guide.

**TABLE 2-3** Ethernet ports and device paths

Ethernet Port	OpenBoot Devalias	Device Path
0	net0	/pci@1e,600000/pci@0/pci@1/pci@0/network@4
1	net1	/pci@1e,600000/pci@0/pci@1/pci@0/network@4,1
2	net2	/pci@1f,700000/pci@0/pci@2/pci@0/network@4
3	net3	/pci@1f,700000/pci@0/pci@2/pci@0/network@4,1

Select the correct TPE connector for the interface you are installing. The server comes with four TPE connectors on the back panel. Your server might also include one or more TPE connectors provided on PCI Ethernet interface cards.

For ease of identifying the Ethernet cables later, use a piece of tape or some other method of marking it to differentiate it from other cables.

---

**Note** – The server also provides a TPE connector for the Sun Advanced Lights Out Manager (ALOM) system controller. Use this connector to access ALOM features through a network. See the *Sun Fire V445 Server Administration Guide*.

---

**2. Connect the server’s serial management port to a terminal server or other serial console device.**

Plug in a Category-5 unshielded twisted-pair cable (which is included in your ship kit) to the appropriate RJ-45 connector on the back panel. The cable length must not exceed 328 feet (100 meters).

You should hear the connector tab snap into place.

---

**Note** – For more information about connecting the Sun Fire V445 to a terminal server, see [“About Setting Up a System Console Device”](#) on page 30.

---

---

## Restoring the Cabinet

See the instructions provided with your cabinet to complete these steps.

1. **Replace the side panels, if applicable.**
2. **Replace the front and back doors, if applicable.**

---

## What Next

The next tasks are to set up a system console device, power on the server, and install the Solaris OS. See [Chapter 3](#).



## Setup and Power-On Procedures

---

This chapter tells you how to set up a system console device and how to power on the server. It also provides guidelines for installing the Solaris OS. Ensure that you have installed the server into a cabinet and, if you have used a 4-post cabinet, and that you have routed cords and cables into the cable management arm (see [Chapter 2](#)) before following the instructions in this chapter.

This chapter contains the following procedures and information:

- [“IMPORTANT: About Initial Configuration and Power-On” on page 29](#)
- [“About Setting Up a System Console Device” on page 30](#)
- [“Preparing to Configure the Primary Network Interface” on page 38](#)
- [“Powering On the Server” on page 39](#)
- [“Installing the Solaris Operating System and Additional Software” on page 44](#)
- [“What Next” on page 45](#)

---

### IMPORTANT: About Initial Configuration and Power-On

The ALOM system controller is operational regardless of system power state. It boots as soon as you attach live power cords to the system. If you want to view the ALOM self-test diagnostics, you must set up a system console device, terminal server or Tip connection *before* attaching the power cords. If you connect the power cords before setting up a connection to the serial management port, you will miss the initial ALOM self-test diagnostics.

---

# About Setting Up a System Console Device

To install the Solaris OS and any application software, you must set up a terminal or other device to access the system console. You can either:

- Connect the system to a terminal server.
- Use an alphanumeric (ASCII) terminal.
- Establish a `tip` connection from another server.

Regardless of the method you choose, for *initial* power-on you must connect the device to the serial management port (SER MGT). After initial power-on, you may use the NET MGT port if you choose. See the *Sun Fire V445 Server Administration Guide* for details.

The following section provides background information on connecting the server to a terminal server. This section is followed by instructions for setting up a terminal server, followed by instructions for setting up an alphanumeric terminal to access the system console, and then followed by instructions for setting up a Tip connection from another Sun system.

For more detailed information, see the *Sun Fire V445 Server Administration Guide*.

---

**Note** – All of the procedures in the following sections assume that you are setting up a system console device by using the default configuration; that is, the system console is directed to the ALOM system controller through the serial management port (SERIAL MGT). After initial power-on, you may choose to use the NET MGT port. See the *Sun Fire V445 Server Administration Guide* for details.

---

## About Connecting the Server to a Terminal Server

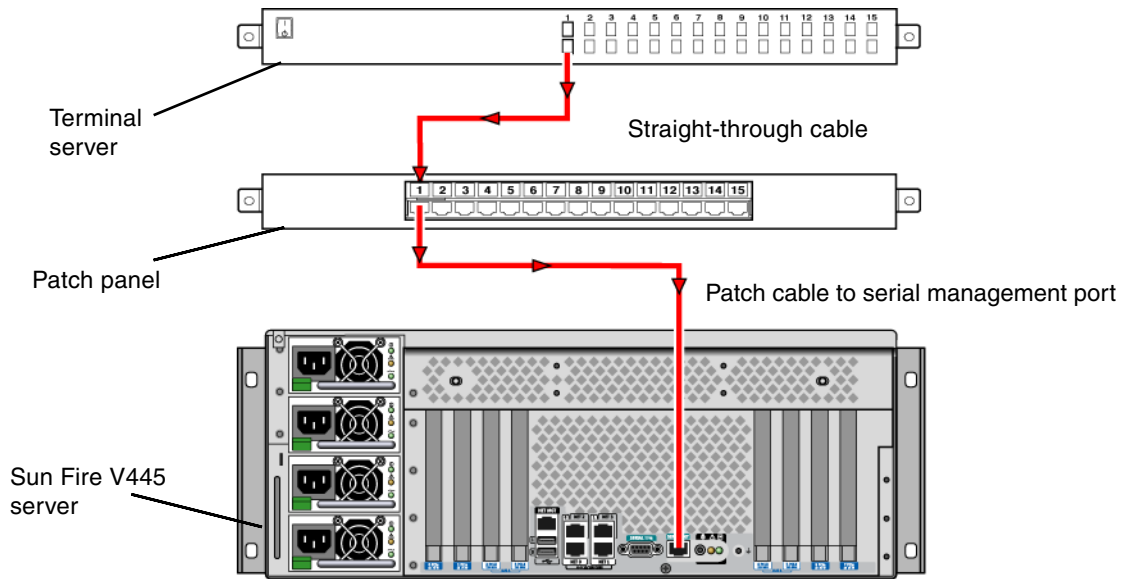
The serial management port on the Sun Fire V445 server is a data terminal equipment (DTE) port. The pinouts for the serial management port correspond with the pinouts for the RJ-45 ports on the serial interface breakout cable supplied by Cisco for use with the Cisco AS2511-RJ terminal server. If you use a terminal server made by another manufacturer, check that the serial port pinouts of the Sun Fire V445 server match those of the terminal server you plan to use.

If the pinouts for the server serial ports correspond with the pinouts for the RJ-45 ports on the terminal server, you have two connection options:



- Connect a serial interface breakout cable directly to the Sun Fire V445 server. See the *Sun Fire V445 Server Administration Guide* for details.
- Connect a serial interface breakout cable to a patch panel and use the straight-through patch cable (supplied by Sun) to connect the patch panel to the server.

The following illustration shows how to connect a patch cable between a terminal server, patch panel, and the serial management port (SERIAL MGT) on the Sun Fire V445 server.



**FIGURE 3-1** Patch Panel Connection Between a Terminal Server and a Sun Fire V445 Server

If the pinouts for the serial management port *do not* correspond with the pinouts for the RJ-45 ports on the terminal server, you need to make a crossover cable that takes each pin on the Sun Fire V445 server serial management port to the corresponding pin in the terminal server's serial port.

[TABLE 3-1](#) shows the crossovers that the cable must perform.

**TABLE 3-1** Pin Crossovers for Connecting to a Typical Terminal Server

Sun Fire V445 Serial Management Port (RJ-45 Connector) Pin	Terminal Server Serial Port Pin
Pin 1 (RTS)	Pin 1 (CTS)
Pin 2 (DTR)	Pin 2 (DSR)
Pin 3 (TXD)	Pin 3 (RXD)
Pin 4 (Signal Ground)	Pin 4 (Signal Ground)
Pin 5 (Signal Ground)	Pin 5 (Signal Ground)
Pin 6 (RXD)	Pin 6 (TXD)
Pin 7 (DSR /DCD)	Pin 7 (DTR)
Pin 8 (CTS)	Pin 8 (RTS)

## Accessing the System Console through a Terminal Server

The following procedure assumes that you are accessing the system console device by connecting a terminal server to the serial management port (SER MGT) of the Sun Fire V440 server.

For detailed information about system console options, see the *Sun Fire V445 Server Administration Guide*.

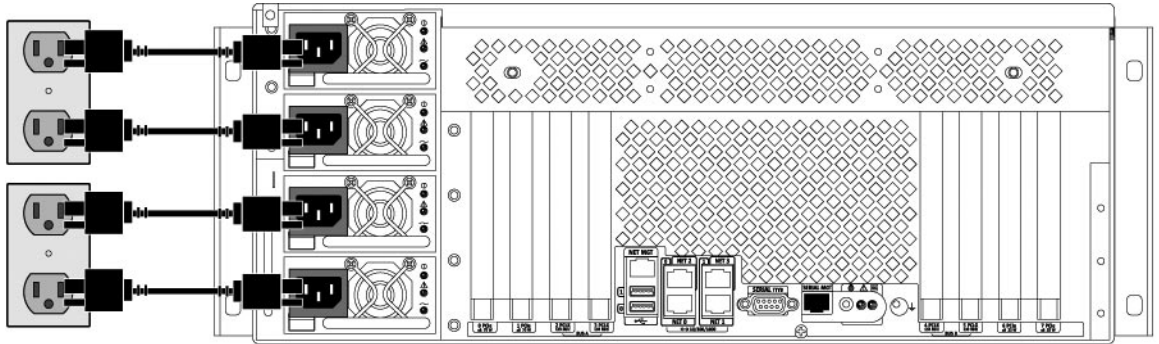
1. **Open a terminal session on the connecting device, and type:**

```
% telnet IP-address-of-terminal-server port-number
```

For example, for a Sun Fire V445 server connected to port 10000 on a terminal server with an IP address of 192.20.30.10, you would type:

```
% telnet 192.20.30.10 10000
```

2. Connect the Sun Fire V445 server's outlet plug of each power cord to the power sequencer in the cabinet (if your type of cabinet includes one), to a grounded outlet strip, or to a grounded AC power outlet.



---

**Caution** – High leakage current. To prevent leakage current in excess of 3.5 mA, a maximum of two power cords can be connected to a single branch circuit. The remaining two power cords must be connected to a different branch circuit.

---

---

**Note** – Each inlet must connect the server to a 15A circuit for North America and Japan, and to a 10A or 16A circuit for Europe. Consult your local electrical codes for any additional requirements. See the instructions provided with your cabinet for information about the power sequencer.

---

---

**Note** – At this point, all system information is delivered to you by way of the ALOM system controller and its software. ALOM is the default method for communicating with the Sun Fire V445 server. For detailed information about using ALOM, consult the *Sun Advanced Lights Out Manager (ALOM) 1.6 Online Help* and the *Sun Fire V445 Server Administration Guide*, which includes information about reconfiguration options.

---

3. Continue setup with the section, [“Preparing to Configure the Primary Network Interface”](#) on page 38.

# Accessing the System Console Through an Alphanumeric Terminal

The following procedure assumes that you are accessing the system console device by connecting an alphanumeric terminal to the serial management port (SERIAL MGT) of the Sun Fire V445 server.

For detailed information about system console options, see the *Sun Fire V445 Server Administration Guide*.

**1. Turn off power to the alphanumeric terminal.**

**2. Attach one end of the serial cable to the alphanumeric terminal's serial port.**

Use an RJ-45 null modem serial cable or an adapter that is appropriate for your device. If you are using a laptop system or a terminal with a DB-9 connector, use an appropriate RJ-45/DB-9 adapter. Plug in this cable or adapter to the terminal's serial port connector.

**3. Attach the serial cable's RJ-45 connector to the server's serial management port (SERIAL MGT) on the ALOM card.**

See the section, ["Connecting the Cords and Cables"](#) on page 24 for an illustration and chart of the various ports.

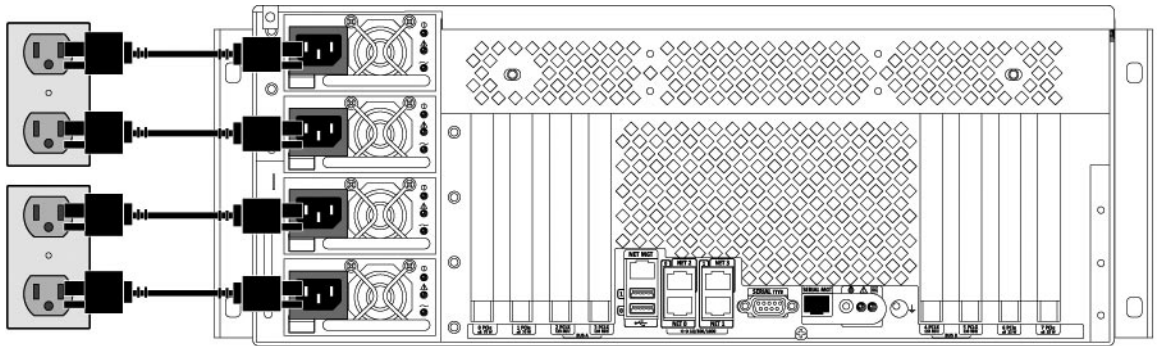
**4. Connect the alphanumeric terminal's power cord to an AC outlet and turn it on.**

**5. Set the terminal to receive:**

- 9600 baud
- 8 bits
- No parity
- 1 stop bit
- No handshake protocol

See the documentation accompanying your terminal for information about how to configure it.

6. Connect the Sun Fire V445 server's outlet plug of each power cord to the power sequencer in the cabinet (if your type of cabinet includes one), to a grounded outlet strip, or to a grounded AC power outlet.



---

**Caution** – High leakage current. To prevent leakage current in excess of 3.5 mA, a maximum of two power cords can be connected to a single branch circuit. The remaining two power cords must be connected to a different branch circuit.

---

---

**Note** – Each outlet must connect the server to a 15A circuit for North America and Japan, and to a 10A or 16A circuit for Europe. Consult your local electrical codes for any additional requirements. See the instructions provided with your cabinet for information about the power sequencer.

---

---

**Note** – At this point, all system information is delivered to you by way of the ALOM system controller and its software. ALOM is the default method for communicating with the Sun Fire V445 server. For detailed information about using ALOM, consult the *Sun Advanced Lights Out Manager (ALOM) 1.1 Online Help* and the *Sun Fire V445 Server Administration Guide*, which includes information about reconfiguration options.

---

7. Continue setup with the section, [“Preparing to Configure the Primary Network Interface”](#) on page 38.

# Accessing the System Console Through a Tip Connection

The following procedure assumes that you are setting up a system console device for the Sun Fire V445 server by connecting the serial port of another Sun system to the serial management port (SERIAL MGT) of the Sun Fire V445 server.

For detailed information about system console options, see the *Sun Fire V445 Server Administration Guide*.

1. **Ensure that the Sun system to which you are establishing the tip connection is powered on and active.**

2. **Connect the RJ-45 serial cable and RJ45/DB25 adapter.**

Use the cable and adapter to connect the other Sun system's `ttyb` serial port to the Sun Fire V445 server's serial management port (SERIAL MGT). Pinouts, part numbers, and other details about the serial cable and adapter are provided in the *Sun Fire V445 Server Service Manual*.

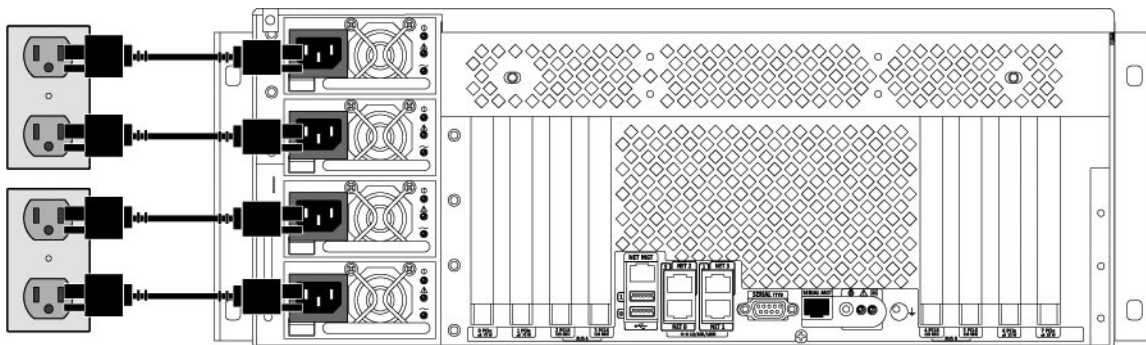
3. **Ensure that the `/etc/remote` file on the Sun system contains an entry for `hardwire`.**

Most releases of the Solaris OS software shipped since 1992 contain an `/etc/remote` file with the appropriate `hardwire` entry. However, if the Sun system is running an older version of the Solaris OS software, or if the `/etc/remote` file has been modified, you may need to edit it. See the *Sun Fire V445 Server Administration Guide* for details.

4. **In a terminal window on the other Sun system, type:**

```
hostname% tip hardwire
```

5. Connect the Sun Fire V445 server's outlet plug of each power cord to the power sequencer in the cabinet (if your type of cabinet includes one), to a grounded outlet strip, or to a grounded AC power outlet.



---

**Caution** – High leakage current. To prevent leakage current in excess of 3.5 mA, a maximum of two power cords can be connected to a single branch circuit. The remaining two power cords must be connected to a different branch circuit.

---

---

**Note** – Each outlet must connect the server to a 15A circuit for North America and Japan, and to a 10A or 16A circuit for Europe. Consult your local electrical codes for any additional requirements. See the instructions provided with your cabinet for information about the power sequencer.

---

The other Sun system responds by displaying:

```
connected
```

The terminal window is now a Tip window directed to the Sun Fire V445 server through the other Sun system's TTYB port. This connection is established and maintained even when the Sun Fire V445 server is completely powered off or just starting up.

---

**Note** – Use a terminal tool, not a console tool. Some `tip` commands might not work properly in a console tool window.

---

---

**Note** – At this point, all system information is delivered to you by way of the ALOM system controller and its software. ALOM is the default method for communicating with the Sun Fire V445 server. For detailed information about using ALOM, consult the *Sun Advanced Lights Out Manager (ALOM) 1.1 Online Help* and the *Sun Fire V445 Server Administration Guide*, which includes information about reconfiguration options.

---

6. Continue setup with the section, “[Preparing to Configure the Primary Network Interface](#)” on page 38.

---

## Preparing to Configure the Primary Network Interface

The following instructions assume that you have chosen a network port and have installed an Ethernet cable, as instructed in the section, “[Connecting Twisted-Pair Ethernet Cables](#)” on page 26. Note that some of these steps are optional, depending on how you want to configure the network. Optional steps are indicated by *italics*.

1. **Choose a host name for the server and make a note of it.**

The host name – no longer than 30 characters – must be unique within the network, consisting only of alphanumeric characters and the dash (-). Do not use a dot in the host name or begin the name with a number or a special character.

2. **Determine the unique Internet Protocol (IP) address of the network interface and make a note of it.**

An IP address must be assigned by the network administrator. Each network device or interface must have a unique IP address.

3. *If the system is part of a subnet, determine the netmask and make a note of it.*

An example of a netmask is 255.255.0.0

4. **Determine which name service that the system will use.**

Your choices are NIS+, NIS, DNS, LDAP, or None. For information about setting up a network name service, consult the *Solaris Naming Setup and Configuration Guide* for your specific Solaris release.

- If the system uses a name service, supply the name of the domain in which the system resides.



- If the name service you use is NIS or NIS+, determine whether you want to specify a name server or have the installation program find one.  
If you want to specify a name server rather than have the installation program find one, make a note of the server's host name and the server's IP address.
- If the name service you use is DNS, make a note of the IP addresses for the DNS server.  
You must enter at least one IP address, and you can enter up to three addresses.
- If the name service you use is LDAP, provide the following information about your LDAP profile:
  - Profile name
  - Profile server
  - IP address

During installation of the Solaris OS, the software automatically detects the system's on-board network interfaces and any installed PCI network interface cards for which native Solaris device drivers exist. The installation program then asks you to select one of the interfaces as the primary network interface and prompts you for the information you gathered. Depending on how you answer other installation questions, the system may prompt you for setup information in addition to the information you gathered in the preceding steps.

You can configure only one network interface during installation of the operating environment. You must configure any additional interfaces separately, after the operating environment is installed. For more information, see the *Sun Fire V445 Server Administration Guide*.

After completing installation of the Solaris OS (in a later step), the primary network interface is ready for operation. The device driver for the server's on-board Ethernet interfaces is automatically installed with the Solaris release. For more information about network interfaces and configuring the Sun Fire V445 server's second Gigabit Ethernet interface, see the *Sun Fire V445 Server Administration Guide*.

---

## Powering On the Server

You can use either of two methods to power on the server:

- Press the Power button
- Use the `poweron` command from the ALOM `sc>` prompt

For information about the status indicators that appear during power-on, see the *Sun Fire V445 Server Administration Guide*.



---

**Caution** – Never move the server when the server power is on. Movement can cause catastrophic hard drive failure. Always power off the server and allow several seconds for the drives to spin down before moving it.

---



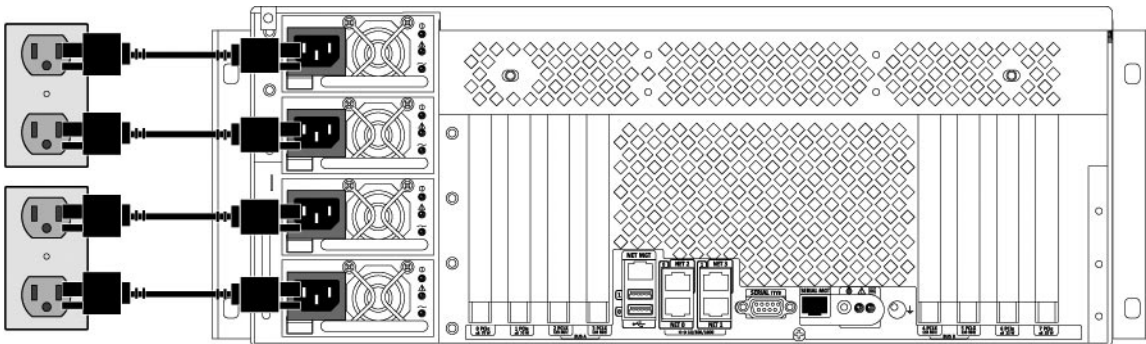
---

**Caution** – The AC power cords provide a discharge path for static electricity. Unless otherwise noted in the *Sun Fire V445 Server Service Manual*, the cords must remain plugged in to the AC outlets when you install or handle internal components.

---

## Powering On Using the Power Button

1. Ensure that your system console device is turned on and active.
2. Turn on power to any peripherals and external storage devices.  
Read the documentation supplied with the device for specific instructions.
3. If you have not already done so, connect the Sun Fire V445 server's outlet plug of each power cord to the power sequencer in the cabinet (if your type of cabinet includes one), to a grounded outlet strip, or to a grounded AC power outlet.



---

**Caution** – High leakage current. To prevent leakage current in excess of 3.5 mA, a maximum of two power cords can be connected to a single branch circuit. The remaining two power cords must be connected to a different branch circuit.

---

---

**Note** – Each outlet must connect the server to a 15A circuit for North America and Japan, and to a 10A or 16A circuit for Europe. Consult your local electrical codes for any additional requirements. See the instructions provided with your cabinet for information about the power sequencer.

---

---

**Note** – Connect each cord to a separate circuit to maximize system availability.

---

The Standby Available indicators on the power supplies are lit, indicating that power is being supplied to the system.

As soon as you plug in the power cord, several boot messages from the ALOM software are displayed on your system console device. The ALOM boot messages end with the ALOM prompt:

```
sc>
```

4. At the ALOM prompt (`sc>`), enter the following command:

```
sc> console -f
```

The system prompts you to create an administrator password.

5. When prompted, create and then confirm an administrator password.

The ALOM prompt is displayed again.

6. At the ALOM prompt (`sc>`), *again* enter the following command:

```
sc> console -f
```

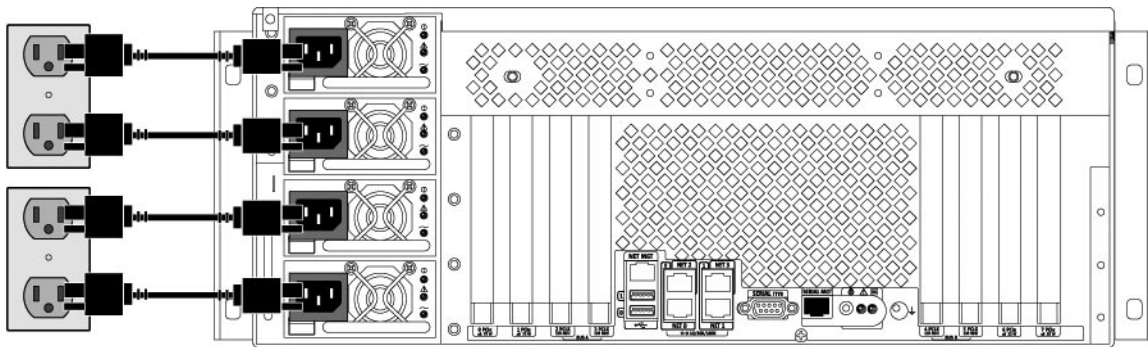
7. Press the Power button on the Sun Fire V445 Server.

The server runs full diagnostics, which can take several minutes. Because the `auto-boot?` parameter is set to `true` by default, installation of the Solaris OS will begin at this point – if your system administrator has configured the network for Solaris JumpStart™ installation. If the network is not so configured, the system will continue the boot sequence using a preinstalled copy of Solaris.

# Powering On Remotely Using the `poweron` Command

The following instructions show you how to power on the server by using the `poweron` command from the ALOM `sc>` prompt. To use this command, you must pay careful attention to the ALOM boot messages, as this procedure requires quick entry of commands.

1. Ensure that your system console device is set up and active.
2. Turn on power to any peripherals and external storage devices.  
Read the documentation supplied with the device for specific instructions.
3. If you have not already done so, connect the Sun Fire V445 server's outlet plug of each power cord to the power sequencer in the cabinet (if your type of cabinet includes one), to a grounded outlet strip, or to a grounded AC power outlet.



---

**Caution** – High leakage current. To prevent leakage current in excess of 3.5 mA, a maximum of two power cords can be connected to a single branch circuit. The remaining two power cords must be connected to a different branch circuit.

---

---

**Note** – Each outlet must connect the server to a 15A circuit for North America and Japan, and to a 10A or 16A circuit for Europe. Consult your local electrical codes for any additional requirements. See the instructions provided with your cabinet for information about the power sequencer.

---

---

**Note** – Connect each cord to a separate circuit to maximize system availability.

---

The Standby indicators on the power supplies are lit, indicating that power is being supplied. As soon as you plug in the power cord, several boot messages from the ALOM software are displayed on your system console device. The ALOM boot messages end with the ALOM `sc>` prompt.

4. **At the ALOM `sc>` prompt, type the `poweron` command:**

```
sc> poweron
```

The ALOM software then prompts you to enter a *new* administrative password.

5. **When prompted, enter and then confirm a new administrative password.**

Once again, the ALOM `sc>` prompt is displayed.

6. **At the ALOM `sc>` prompt, again type the `poweron` command:**

```
sc> poweron
```

The `poweron` command is executed and the `sc>` prompt is again displayed.

You must complete the next step *quickly*, before the ALOM 60-second timeout expires. If the timeout expires, enter `#.` to return to the ALOM prompt.

7. **Quickly enter the `console` command:**

```
sc> console -f
```

This switches the system console from ALOM to OpenBOOT. The display will now show console output as the system boots.

After running full diagnostics, the system banner is displayed on the system console device and then the `ok` prompt is displayed. If your system administrator has configured the network for Solaris JumpStart installation, then installation of the Solaris OS will begin at this point. If the network is not so configured, then the system will continue the boot sequence using the Solaris release that has been preinstalled on the system.

---

# Installing the Solaris Operating System and Additional Software

---

**Note** – Your system may already have the Solaris OS pre-installed. If you want to re-install the Solaris OS, see your Solaris Media Kit for instructions.

---

You must have set up a system console device before you can install the Solaris OS. See the section, [“About Setting Up a System Console Device” on page 30](#). Be sure that you are using the Solaris release supported by the Sun Fire V445 server. See the *Sun Fire V445 Server Product Notes* for additional information.

---

**Note** – The Solaris Media Kit, which contains the Solaris OS CDs and additional software CDs, must be ordered separately. Contact your Sun service provider if you do not have a Solaris Media Kit.

---

## 1. Locate your Solaris Media Kit.

## 2. Install the Solaris OS on your server.

- Read the *Start Here* document that is included in the Solaris Media Kit.
- Complete each step to install the Solaris OS.

Install the software using any of four methods, fully explained in the documentation included in the Solaris Media Kit:

- Solaris Web Start
- Solaris interactive installation
- Solaris JumpStart or (Custom JumpStart)
- Over a network

## 3. Load additional software from the Solaris Software Supplement CD (optional).

The Solaris Media Kit includes the Solaris Software Supplement CD with additional software to help you operate, configure, and administer the server. See the documentation provided in the Solaris Media Kit for a listing of included software.

To install the software from the Solaris Software Supplement CD, use the installation utility, Solaris Web Start. For instructions, see your Solaris documentation, which is included in the Solaris Media Kit.

**4. Install any software patches listed in the *Sun Fire V445 Server Product Notes*.  
Download the**

A list of recommended patches is also available on the SunSolve Online<sup>SM</sup> Web site at <http://sunsolve.sun.com>. You can obtain patches and installation instructions from your Sun service provider or by downloading them from the SunSolve Online Web site.

**5. Run the Sun Install Check tool to validate installation configuration.**

The tool identifies unsupported firmware and hardware configurations, identifying conflicts with configuration rules. The tool also ensures that your firmware is current and that you have all required patches installed. The URL for obtaining this tool is: <http://sunsolve.sun.com/pub-cgi/show.pl?target=installcheck/installcheck>

---

## What Next

The Sun Fire V445 server is now ready for use and, if you desire, additional configuration.

- Consult the *Sun Fire V445 Server Administration Guide* for detailed information and instructions relating to configuration and administration of the server, or for help with any problems you may encounter.
- Refer to the *Sun Fire V445 Server Service Manual* for parts replacement and installation information and instructions.
- Refer to the *Sun Advanced Lights Out Manager (ALOM) 1.6 Online Help* for information about how to use the ALOM software.





## Installation Reference

---

This appendix includes background and reference information that can help you with installation of your Sun Fire V445 server. All of the information in this appendix is related directly to instructions in this guide.

This appendix includes the following sections:

- [“System Indicators” on page 45](#)
- [“System Controller Ports” on page 48](#)
- [“4-Post Cabinet Requirements” on page 50](#)

---

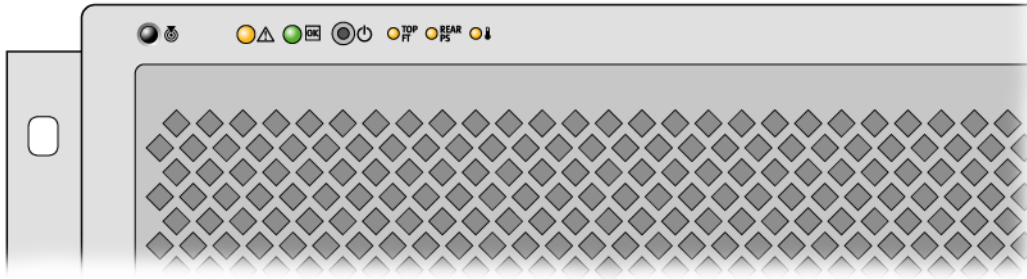
## System Indicators

As you install your Sun Fire V445 server, be aware of several system status indicators on both the front and back panels. These indicators provide general system status, alert you to system problems, and help you to determine the location of system faults.

During system startup, the indicators are toggled on and off to verify that each one is working correctly. Indicators located on the front panel work in conjunction with specific fault indicators. For example, a fault in the power supply subsystem illuminates the power supply Service Required indicator on the affected power supply, as well as the Service Required indicator. Since all front panel status indicators are powered by the system’s standby power source, fault indicators remain lit for any fault condition that results in a system shutdown.

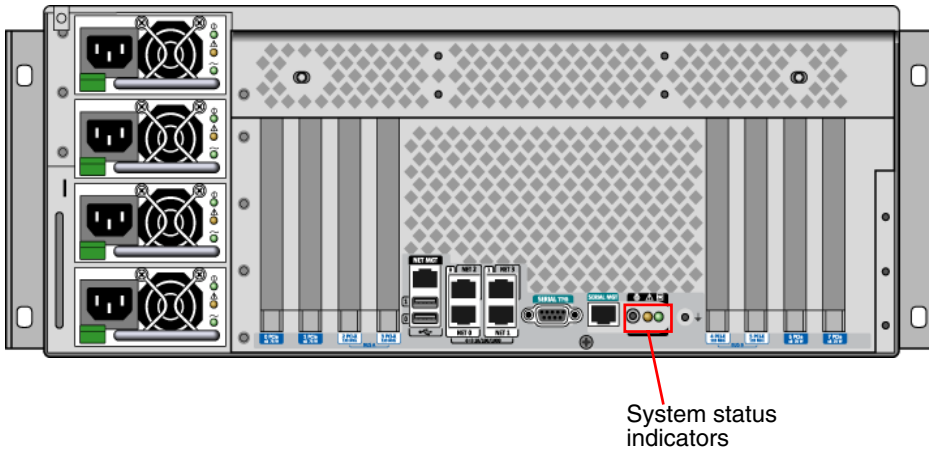
At the top left of the system as you look at its front are six system status indicators. Power/OK indicator and the Service Required indicator provide a snapshot of the overall system status. The Locator indicator helps you to quickly locate a specific

system even though it may be one of numerous systems in a room. The Locator indicator/button is at the far left in the cluster, and is lit remotely by the system administrator, or toggled on and off locally by pressing the button.



**FIGURE A-1** Front system control panel




Each system status indicator has a corresponding indicator on the back panel.



**FIGURE A-2** Back panel status indicators


Listed from left to right, the system status indicators operate as described in the following table [TABLE A-1](#)

**TABLE A-1** System Status indicators

Icon	Name	Description
	Locator	This white indicator is lit by Solaris command, Sun Management Center command, or Advanced Lights Out Manager (ALOM) commands to help you locate the system. See the <i>Sun Fire V440 Server Administration Guide</i> for information about turning on the Locator indicator.
	Service Required	This amber indicator lights steadily when a system fault is detected. For example, the system Service Required indicator lights when a fault occurs in a power supply or fan tray.  In addition to the system Service Required indicator, other fault indicators might also be lit, depending on the nature of the fault. If the system Service Required indicator is lit, check the status of other fault indicators on the front panel to determine the nature of the fault. See the <i>Sun Fire V445 Server Administration Guide</i> for more information.
	Power/OK	This green indicator lights continuously when the system power is on.

Additional fault indicators indicate the type of service required. These indicators are described in [TABLE A-2](#)

**TABLE A-2** System Diagnostic indicators

Icon	Name	Location
<b>TOP FT</b>	Fan Tray Fault	This indicator indicates a fault in a fan tray. Additional indicators on the top panel indicate which fan tray requires service.
<b>REAR PS</b>	Power Supply Fault	The indicator indicates a fault in a power supply. Look at the individual power supply status indicators (on the back panel) to determine which power supply requires service.
	CPU Overtemperature	This indicator indicates that a CPU has detected an overtemperature condition. Look for any fan failures, as well as a local overtemperature condition around the server.

# System Controller Ports

There are two system controller ports. Both use an RJ-45 connector.

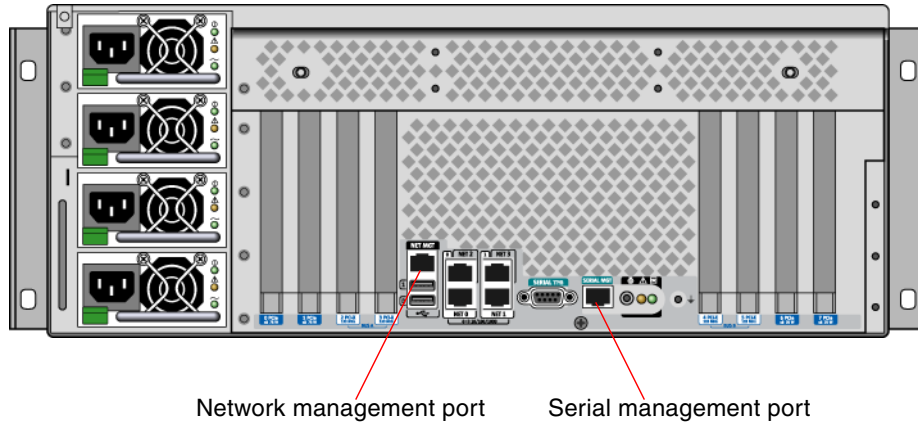


FIGURE A-3 System controller ports

---

**Note** – For a description of the other system ports, see the *Sun Fire V445 Server Administration Guide*.

---

## Network Management Port

This port provides direct network access to the ALOM system controller, when configured, and can access the ALOM prompt and system console output.

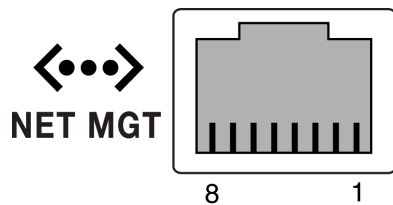


FIGURE A-4 Network management port

---

**Note** – The system controller is accessed through the serial management port by default. You must reconfigure the system controller to use the network management port. For more information, see the *Sun Fire V445 Server Administration Guide*.

---

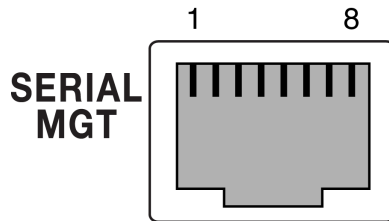
The network management port has indicators which operate as described in [TABLE A-3](#).

**TABLE A-3** Network Management Port indicator

Name	Description
Link	This green indicator is lit when an Ethernet connection is present.
Activity	This green indicator is lit when the Ethernet connection is active.

## Serial Management Port

The serial management port provides the default connection to the system controller. The serial management port is an RJ-45 connector that can be accessed from the back panel. You can connect to the serial management port using a VT100 terminal, a tip connection, or a terminal server.



**FIGURE A-5** Serial management port

For serial management port connector signals, see [TABLE A-4](#).

**TABLE A-4** Serial Management Connector Signals

Pin	Signal Description	Pin	Signal Description
1	Request to Send	5	Ground

**TABLE A-4** Serial Management Connector Signals

Pin	Signal Description	Pin	Signal Description
2	Data Terminal Ready	6	Receive Data
3	Transmit Data	7	Data Set Ready
4	Ground	8	Clear to Send

---

## 4-Post Cabinet Requirements

The server is designed so that you can install it into a 72-inch (184-cm) tall Sun StorEdge™ Expansion Cabinet or other EIA-compliant industry-standard cabinet that meets the requirements listed in the following table. You need a Sun rackmounting kit for each server that you rackmount.

---

**Note** – The server is fully serviceable in a 4-post cabinet when it is extended on its slide assemblies.

---

**TABLE A-5** 4-Post Cabinet Requirements

Cabinet Feature	Requirement
Load-bearing capacity	The rack must firmly support the weight of as many Sun Fire V445 servers installed in the cabinet (each server weighs up to 82 lb/37.2 kg), plus the weight of the rackmounting hardware, and the weight of any other installed devices.
Vertical space requirements	Each server requires four rack units (7.0 inch/17.78 cm) of vertical space for rack installation. A 72-inch (184-cm) Sun cabinet ships with a power sequencer so it can <i>nominally</i> hold up to eight servers (with a power sequencer there are 36 rack units of usable space). However, because of electrical power issues, the actual maximum of systems per rack is six.
Doors and panels	If you are using a Sun StorEdge Expansion Cabinet, you can remove the front and back doors and the side panels to increase access to the server. Otherwise, see the instructions provided with the cabinet.

---

**TABLE A-5** 4-Post Cabinet Requirements (*Continued*)

<b>Cabinet Feature</b>	<b>Requirement</b>
Antitip protection	The cabinet must be bolted securely to the floor or equipped with two sturdy and extendable antitip legs. You must prevent the cabinet from tilting forward when one or more servers or devices are fully extended out the front of the cabinet.
Airflow	<p>The server operating airflow is 92 cfm, regardless of ambient air and altitude. This airflow provides appropriate cooling up to 104° F (40° C) and 10,000 feet (3000 meters).</p> <p>For proper ventilation of the server, the front and back doors must comply with the following minimum open area requirements.</p> <ul style="list-style-type: none"><li>• 60 percent of the area of the front door that is directly in front of the server must be open.</li><li>• 63 percent of the area of the back door that is directly behind the server must be open.</li><li>• Maintain a minimum of 1.5 inches (3.8 cm) clearance between the server and any front or back doors.</li></ul> <p>If the doors of the cabinet do not meet the open area requirements, remove the door or doors that do not comply.</p>
Vertical mounting rails	<p>The cabinet must have two pairs of vertical mounting rails (one pair in front, one pair in back) that conform to the EIA (RETMA) standard for mounting hole spacing.</p> <p>Left-side-to-right-side rail spacing (mounting hole center to mounting hole center) for front and back rails must be 17.72 inches (45 cm).</p> <p>Front-to-back rail spacing must be at least 23 inches (58.42 cm) and not more than 34.5 inches (87.63 cm) from the outside face of the front rail to the outside face of the back rail.</p> <p>Front and back vertical rail mounting faces must be parallel with each other and with the front plane of the rack.</p>

**TABLE A-5** 4-Post Cabinet Requirements (*Continued*)

<b>Cabinet Feature</b>	<b>Requirement</b>
EMI shielding	Electromagnetic interference (EMI) shielding requirements are met by the system chassis and metal side panels, which remain in place when the server is rackmounted.
Minimum service access	An area not less than 3 feet (1 meter) deep and 6 feet (2 meters) wide must be available in front of the cabinet, for installation and service access.
Fire containment	The cabinet must meet Underwriters Laboratories, Inc., and TUV Rheinland of N.A. requirements for fire containment.



# Index

---

## A

- airflow 53
- ALOM
  - command prompt 43
  - initial power-on and 29
- alphanumeric terminal 34
- antitip legs 10

## B

- back panel connectors 25
- baud rate 34
- boxes shipped to you 1

## C

- cabinet
  - airflow requirement 53
  - antitip legs 10, 53
  - antitip requirement 53
  - doors and panels requirement 52
  - EMI shielding requirement 54
  - fire containment requirement 54
  - installing server into 17
  - installing slide assemblies 13
  - load-bearing capacity 52
  - preparing for server installation 10
  - server compatibility requirements 52
  - vertical mounting rails requirement 53
  - vertical space requirements 52
- cable management arm (CMA)
  - attaching cables to 22
  - installing 20
- checklist of parts 1

- Cisco L2511 Terminal Server, connecting 30
- CPU Overtemperature indicator 49

## D

- disk drive caution 40
- documentation, accessing 3

## E

- EIA-compliant rack 5
- EMI shielding 54
- Ethernet connection 26

## F

- fasteners included with rackmounting kit 8

## I

- initial power-on and ALOM 29
- inner glides
  - attaching to chassis 9
  - sliding into slide assemblies 17

## L

- Locator indicator/button 48, 49

## M

- monitor 1
- mounting holes, locating 11
- moving the system, precautions 40

## N

- network

- configuring primary interface 38, 39
- network management port 50

## **O**

- optional components, installing 24

## **P**

- parity 34
- parts, checklist of 1
- patch panel, and using to attach to terminal server 31
- planning installation 3
- power, turning on 40, 42
- Power/OK indicator/button 49
- powering on 39
  - using Power button 40
  - using remote poweron command 42

## **R**

- rack alignment template 11
- rackmounting checklist 6
- rackmounting kit
  - fasteners 8
  - parts included 7
- rackmounting, tools required for 8

## **S**

- serial management port 51
- serial port, connecting to 34
- shipping (what you should receive) 1
- shipping kit contents 2
- slide assemblies
  - adjusting depth of 13
  - installing into cabinet 13
- Solaris Media Kit 1, 3, 44
- Solaris OS
  - installing 44
- Sun Install Check tool 45
- Sun StorEdge Expansion Cabinet 5
- system console, accessing via alphanumeric terminal 34
- system indicators 47

## **T**

- terminal server
  - and patch panel 31

- connection 30
- pinouts 32
- using to access the system console 32

## **V**

- vertical mounting holes, locating 11