



Sun Fire™ 280R Server Setup and Rackmounting Guide

Sun Microsystems, Inc.
901 San Antonio Road
Palo Alto, CA 94303-4900 U.S.A.
650-960-1300

Part No. 806-4805-10
January 2001, [Revision A](#)

[Send comments about this document to: docfeedback@sun.com](mailto:docfeedback@sun.com)

Copyright 2001 Sun Microsystems, Inc., 901 San Antonio Road, Palo Alto, CA 94303-4900 U.S.A. All rights reserved.

This product or document is distributed under licenses restricting its use, copying, distribution, and decompilation. No part of this product or document may be reproduced in any form by any means without prior written authorization of Sun and its licensors, if any. Third-party software, including font technology, is copyrighted and licensed from Sun suppliers.

Parts of the product may be derived from Berkeley BSD systems, licensed from the University of California. UNIX is a registered trademark in the U.S. and other countries, exclusively licensed through X/Open Company, Ltd.

Sun, Sun Microsystems, the Sun logo, AnswerBook2, docs.sun.com, Sun Fire, and Solaris are trademarks, registered trademarks, or service marks of Sun Microsystems, Inc. in the U.S. and other countries. All SPARC trademarks are used under license and are trademarks or registered trademarks of SPARC International, Inc. in the U.S. and other countries. Products bearing SPARC trademarks are based upon an architecture developed by Sun Microsystems, Inc.

The OPEN LOOK and Sun™ Graphical User Interface was developed by Sun Microsystems, Inc. for its users and licensees. Sun acknowledges the pioneering efforts of Xerox in researching and developing the concept of visual or graphical user interfaces for the computer industry. Sun holds a non-exclusive license from Xerox to the Xerox Graphical User Interface, which license also covers Sun's licensees who implement OPEN LOOK GUIs and otherwise comply with Sun's written license agreements.

Federal Acquisitions: Commercial Software—Government Users Subject to Standard License Terms and Conditions.

DOCUMENTATION IS PROVIDED "AS IS" AND ALL EXPRESS OR IMPLIED CONDITIONS, REPRESENTATIONS AND WARRANTIES, INCLUDING ANY IMPLIED WARRANTY OF MERCHANTABILITY, FITNESS FOR A PARTICULAR PURPOSE OR NON-INFRINGEMENT, ARE DISCLAIMED, EXCEPT TO THE EXTENT THAT SUCH DISCLAIMERS ARE HELD TO BE LEGALLY INVALID.

Copyright 2001 Sun Microsystems, Inc., 901 San Antonio Road, Palo Alto, CA 94303-4900 Etats-Unis. Tous droits réservés.

Ce produit ou document est distribué avec des licences qui en restreignent l'utilisation, la copie, la distribution, et la décompilation. Aucune partie de ce produit ou document ne peut être reproduite sous aucune forme, par quelque moyen que ce soit, sans l'autorisation préalable et écrite de Sun et de ses bailleurs de licence, s'il y en a. Le logiciel détenu par des tiers, et qui comprend la technologie relative aux polices de caractères, est protégé par un copyright et licencié par des fournisseurs de Sun.

Des parties de ce produit pourront être dérivées des systèmes Berkeley BSD licenciés par l'Université de Californie. UNIX est une marque déposée aux Etats-Unis et dans d'autres pays et licenciée exclusivement par X/Open Company, Ltd.

Sun, Sun Microsystems, le logo Sun, AnswerBook2, docs.sun.com, Sun Fire, et Solaris sont des marques de fabrique ou des marques déposées, ou marques de service, de Sun Microsystems, Inc. aux Etats-Unis et dans d'autres pays. Toutes les marques SPARC sont utilisées sous licence et sont des marques de fabrique ou des marques déposées de SPARC International, Inc. aux Etats-Unis et dans d'autres pays. Les produits portant les marques SPARC sont basés sur une architecture développée par Sun Microsystems, Inc.

L'interface d'utilisation graphique OPEN LOOK et Sun™ a été développée par Sun Microsystems, Inc. pour ses utilisateurs et licenciés. Sun reconnaît les efforts de pionniers de Xerox pour la recherche et le développement du concept des interfaces d'utilisation visuelle ou graphique pour l'industrie de l'informatique. Sun détient une licence non exclusive de Xerox sur l'interface d'utilisation graphique Xerox, cette licence couvrant également les licenciés de Sun qui mettent en place l'interface d'utilisation graphique OPEN LOOK et qui en outre se conforment aux licences écrites de Sun.

LA DOCUMENTATION EST FOURNIE "EN L'ETAT" ET TOUTES AUTRES CONDITIONS, DECLARATIONS ET GARANTIES EXPRESSES OU TACITES SONT FORMELLEMENT EXCLUES, DANS LA MESURE AUTORISEE PAR LA LOI APPLICABLE, Y COMPRIS NOTAMMENT TOUTE GARANTIE IMPLICITE RELATIVE A LA QUALITE MARCHANDE, A L'APTITUDE A UNE UTILISATION PARTICULIERE OU A L'ABSENCE DE CONTREFAÇON.



Contents

- Preface v**

- 1. Getting Started 1**
 - Unpack the System 1
 - Verify the Kit Contents 2
 - Accessory and Slide Assembly Box Contents 3

- 2. Installing the System Into the Rack Enclosure 5**
 - Installation Options 5
 - Before You Begin the Installation 6
 - Tools Required 6
 - Safety Precautions 7
 - Assembled Slide Layout 8
 - Prepare the Rack Enclosure 9
 - Install the Slide Assemblies Into the Rack Enclosure 11
 - Install the System Into the Rack Enclosure 13

- 3. Setting Up the System 19**
 - Connect the Power Cord 20
 - Connect the Twisted-Pair Ethernet (TPE) Cable 22
 - Install a System Console 23

Set Up a <code>tip</code> Connection	23
Connect an ASCII Terminal	24
Install a Graphics Console	25
Restore the Rack Enclosure	28
Power On the System	28
Install the Operating System	31
Install Online Documentation	31
A. Rack Enclosure Requirements	33

Preface

The *Sun Fire 280R Server Setup and Rackmounting Guide* provides instructions for installing and setting up the Sun Fire™ 280R server in an Electronic Industries Association (EIA)-compliant standard rack.

After you set up the server, you will need to consult the *Sun Fire 280R Server Owner's Guide* for instructions about how to install the software. The software instructions are designed for an experienced system administrator with networking knowledge.

How This Book Is Organized

The chapters in this book are organized as follows:

Chapter 1 describes the boxed server and its rackmounting hardware kit contents so that you can verify what was shipped to you.

Chapter 2 provides step-by-step instructions for rackmounting the server into a 72-inch (184-cm) tall Sun™ expansion cabinet or other EIA-compliant rack enclosure.

Chapter 3 describes how to attach the necessary cords and cables to get the server up and running. To install the software, you must use the *Sun Fire 280R Server Owner's Guide* for further instructions.

Appendix A lists the safety requirements of a 72-inch (184-cm) tall Sun expansion cabinet or other EIA-compliant industry-standard rack enclosure.

Related Documentation

Application	Title	Part Number
Configuration and setup	<i>Sun Fire 280R Server Owner's Guide</i>	806-4806-10
Parts replacement and service ¹	<i>Sun Fire 280R Server Service Manual</i>	806-4807-10

¹With the exception of the internal disk drives, all other parts must be replaced by qualified service providers.

Ordering Sun Documentation

Fatbrain.com, an Internet professional bookstore, stocks select product documentation from Sun Microsystems, Inc. For a list of documents and how to order them, visit the Sun Documentation Center on Fatbrain.com at the public Universal Resource Locator (URL):

<http://www.fatbrain.com/documentation/sun>

Accessing Sun Documentation Online

The `docs.sun.com`SM web site enables you to access Sun technical documentation on the Web. You can browse the `docs.sun.com` archive or search for a specific book title or subject at the public URL:

<http://docs.sun.com>

Sun Welcomes Your Comments

We are interested in improving our documentation and welcome your comments and suggestions. You can email your comments to us at:

`docfeedback@sun.com`

Please include the part number (806-4805-10) of your document in the subject line of your email.

Getting Started

This guide shows you how to install the Sun Fire 280R server into a Sun expansion cabinet, or other EIA 310-compliant rack enclosure. Following the use of this Setup Guide for installing the server into a rack, you will need to use the *Sun Fire 280R Server Owner's Guide* for instructions about how to install the software.

To install a Sun Fire 280R server into a rack enclosure, complete the following tasks in the order listed:

- Unpack the system and verify the kit contents. See Chapter 1.
- Rackmount the server. See Chapter 2.
- Set up the system. See Chapter 3.

Unpack the System

Your system is shipped from the factory with most internal options installed. Peripherals that are not factory installed are shipped separately. With the exception of internal disk drives in the Sun Fire 280R server, *all component part installation or replacement* must be performed by a qualified service provider. If your system options are not fully installed, consult the *Sun Fire 280R Server Owner's Guide* or the *Sun Fire 280R Server Service Manual* for installation instructions or contact a qualified service provider.

Inspect all shipping cartons for evidence of physical damage. If a shipping carton is damaged, request that the carrier's agent be present when the carton is opened. Keep all contents and packing material for the agent's inspections.

Check that you have received all of the parts you ordered. Contact Sun Microsystems or your distributor/reseller if you are missing anything.

Verify the Kit Contents

The shipping carton contains the following parts:

- Sun Fire 280R server
- Accessory box
- Slide assembly box

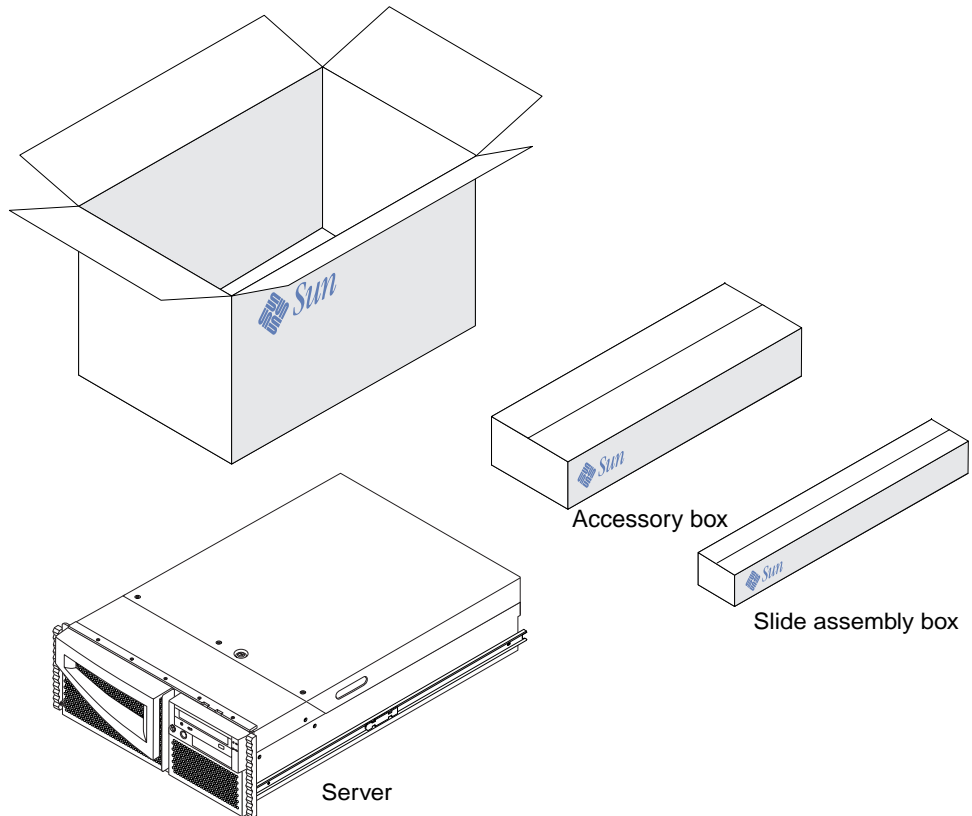

Accessory and Slide Assembly Box Contents

You are shipped one Sun rackmounting kit for each server that you intend to rackmount. The accessory and slide assembly boxes contain one assembled Sun rackmounting slide kit and the following parts:

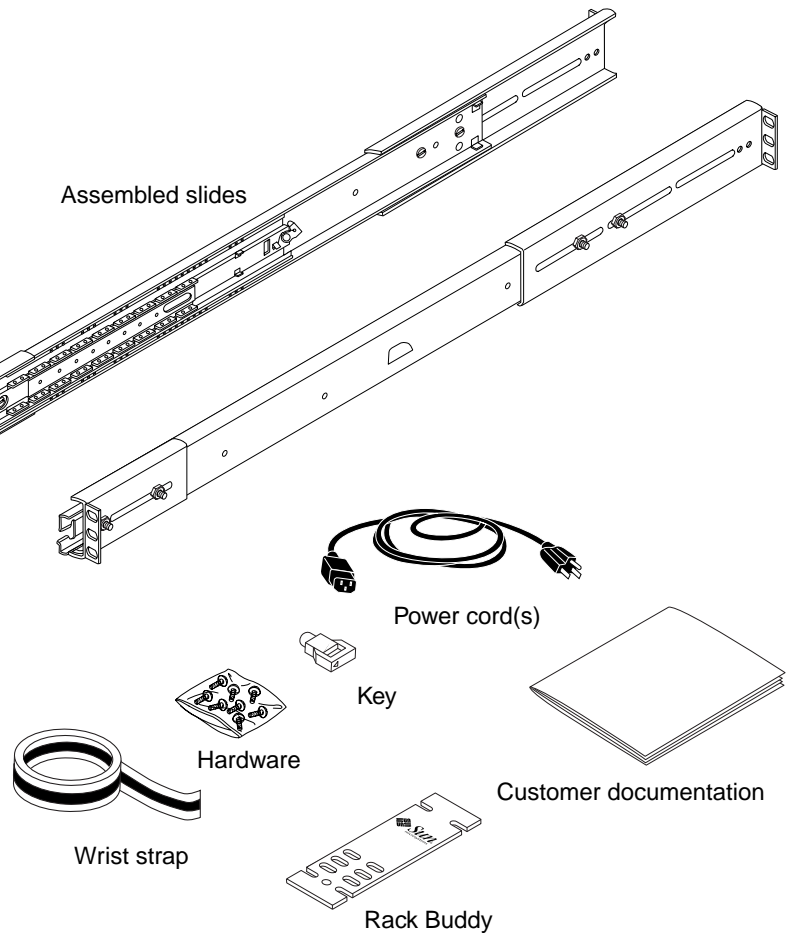

Note – The slide assemblies' innermost glides are already installed on the outside of the server enclosure. You may remove them from the system for rack tray or desktop installation.

Use the key for controlling the system in “Setting Up the System” on page 19. The wrist strap is not needed for the rackmounting procedures. Both the key and the wrist strap are needed for procedures described in the *Sun Fire 280R Server Service Manual* and the *Sun Fire 280R Server Owner’s Guide*.

The accessory box includes a plastic bag of hardware containing screws, nuts, and washers that are shown below in actual size.

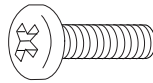

Screws
(10-32 x 3/4)



Flat
washer (8-32)
(spare)

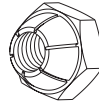

Locking
nut (8-32)
(spare)

You need 8 of the 10-32 x 3/4 screws to attach the slide assemblies to the rack. After installing the slide assemblies, any unused hardware is a spare piece.

Note – Bar nuts are not used in Sun rack enclosures. Bar nuts are required (but not included) for *non-threaded* rack enclosures. See your rack enclosure instructions for more information.

Installing the System Into the Rack Enclosure

This chapter provides step-by-step instructions for rackmounting the server into a Sun expansion cabinet or other EIA-compliant rack enclosure.

To rackmount a Sun Fire 280R server, complete the following tasks in the order listed:

- “Installation Options” on page 5
- “Prepare the Rack Enclosure” on page 9
- “Install the Slide Assemblies Into the Rack Enclosure” on page 11
- “Install the System Into the Rack Enclosure” on page 13

The *Sun Fire 280R Server Rackmounting Overview* included with your documentation set illustrates the rackmounting steps in a convenient, graphical overview. This chapter provides detailed information about each step.

Installation Options

Many of the options ordered with your system are pre-installed at the factory. For information about how to install other options, see the *Sun Fire 280R Server Service Manual* or contact your qualified service provider. For information about installing one additional internal disk drive, see the *Sun Fire 280R Server Owner’s Guide*.

Before You Begin the Installation

- Unpack the system and verify the contents. See Chapter 1 for instructions.
- Unpack the accessory box and place the assembled slides and hardware on a clear work surface.
- Verify that you have the components and hardware shown in “Accessory and Slide Assembly Box Contents” on page 3.
- Read the rack enclosure requirements described in Appendix A of this guide to ensure that you meet the enclosure requirements.
- Read the safety precautions that follow the “Tools Required” section.
- For faster installation and setup, use two sets of the required tools. Two persons are required to install the server.

Tools Required

- Phillips No. 2 screwdriver
- Flat-blade screwdriver
- Set of appropriate Allen wrenches to remove the side panels on some rack enclosures
- Adjustable wrench to tighten the nuts on the mounting brackets
- Spirit level for leveling the rackmount enclosure front-to-back and side-to-side (if necessary)

Safety Precautions

For a complete description of the safety precautions to follow when installing a Sun Fire 280R server, see the *Sun Fire 280R Server Owner's Guide*.



Caution – Install the system as low as possible into the rack enclosure. For the best stability, do not install the system above equipment that weighs less than the Sun Fire 280R server weight (a maximum of 75 lb/34 kg).



Caution – The system is heavy. In the following procedures, two persons are required to move the system in the procedure. Two persons are also required to align and install the slide assemblies into the rack.



Caution – For proper ventilation, each system in the rack enclosure requires 28 square inches (181 square cm) of unrestricted airflow into the front of the system, and 23 square inches (148 square cm) of unrestricted exhaust port at the back of the system. Maintain a minimum 1.5 inches (3.8 cm) clearance between the system and any front or back doors. See Appendix A for more information.

Assembled Slide Layout

Below is a view of the assembled slide assembly. The rack installation is detailed in the following pages for the two slide assemblies.

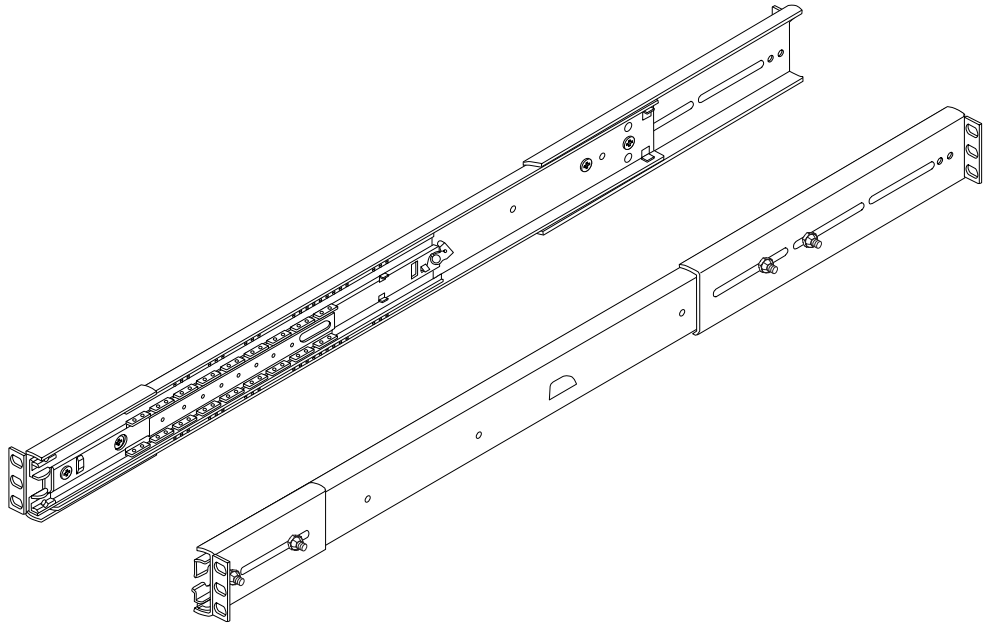

Prepare the Rack Enclosure

1. **Open, and remove if applicable, the front and back doors of the rack enclosure.**

See the instructions provided with your rack enclosure.

2. **Stabilize the rack enclosure by extending its anti-tip legs or bolting the rack enclosure securely to the floor.**

See the instructions provided with your rack enclosure and read Appendix A.

3. **Remove the side panels from the rack enclosure, if applicable.**

See the instructions provided with your rack enclosure. Removing the side panels can improve access to the nuts and screws that you install when securing the system in the rack enclosure.

4. **Measure the depth of the rack enclosure.**

See “Vertical Mounting Rail Requirements” in Appendix A for more information about the range of depths in EIA-compliant industry-standard rack enclosures.

5. **Using a felt tip marker and the Rack Buddy, locate and mark the rack rail holes to use to attach each slide assembly.**

The Rack Buddy template can help you locate the rack rail holes to use for each slide assembly. The Rack Buddy is four rack units (7.0 inches/17.78 cm) or 12 holes tall. Because the rail holes on a standard rack enclosure are arranged in sets of three holes spaced $\frac{5}{8}$ ths, $\frac{5}{8}$ ths, and $\frac{4}{8}$ ths of an inch apart, which *two holes* of the three you use for attaching a slide assembly varies depending on exactly where in the rack the system is located.

- a. **Examine the Rack Buddy. See the next figure.**

Two of the middle three pairs of holes are for mounting the slide bracket (you only use two screws in two of these three holes to attach each slide to the rack). The top and bottom openings in the template locate the system retainer screws that hold the system in the rack after it is installed.

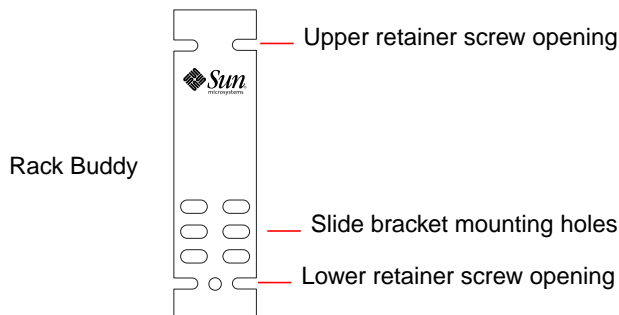

- b. Place the Rack Buddy over the left front vertical rack rail. See the next figure.
- c. Move the bottom of the Rack Buddy to the location on the rack rail where the bottom of the system will be located.
- d. Adjust the Rack Buddy until the lower retainer opening is centered on the hole in the rail.
- e. Looking through the three middle holes on the Rack Buddy, locate and mark the *two* rack rail holes that are most visible through the template. Use these two rack rail holes to attach the slide assembly to the front rail. You will only use two of the three holes to attach the slide assembly. Mark the corresponding holes on the right front vertical rack rail.

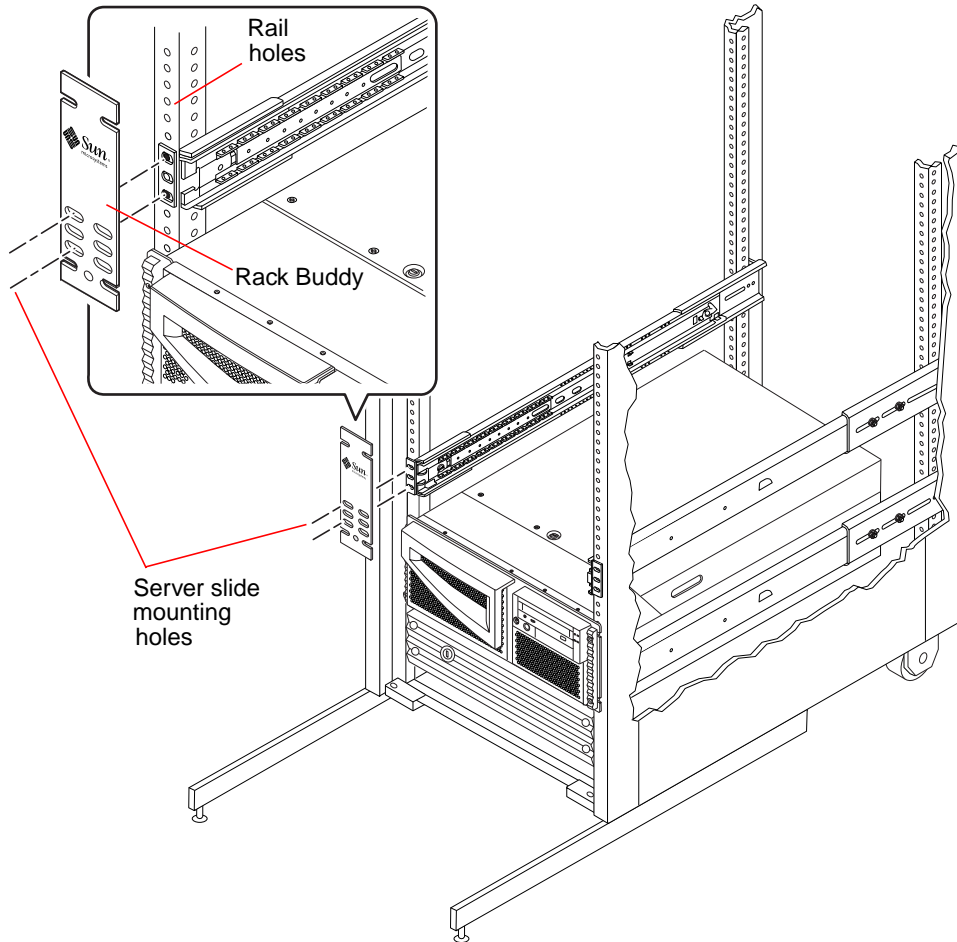

Install the Slide Assemblies Into the Rack Enclosure

You can either count the rack rail holes or use the Rack Buddy to make sure that each slide assembly is installed at the same height front-to-back and side-to-side in the rack. See Step 5 of “Prepare the Rack Enclosure” on page 9 for more information about using the Rack Buddy.

Before you begin the installation:

- Complete “Prepare the Rack Enclosure” on page 9.
 - If this is the first system you are installing into the rack enclosure, use holes 9 and 10 or 11 (this assumes that an AC power sequencer occupies holes 1 through 6 in the bottom of the rack).
 - Install the slide assemblies into the lowest available position.
 - Install additional servers from the base up in the rack enclosure.
1. **If necessary, adjust the back mounting bracket forward or backward on the slide assembly to accommodate the depth of the rack.**

Use the depth you measured in Step 4 of “Prepare the Rack Enclosure” on page 9.

2. **Secure the slide bracket assemblies to the front and back mounting rails using Phillips 10-32 panhead screws.**

Use the holes you marked in Step 5 of “Prepare the Rack Enclosure” on page 9. Do not completely tighten the screws until after the server is installed. Ensure that all the screws are in place, and that the slide assemblies are secure and level.

- a. **Attach one slide assembly to the right rack mounting rail, and the other slide assembly to the left rack mounting rail. See the next figure.**
- b. **With the help of an assistant, position each slide assembly on the inside of the rack enclosure with the front (short) mounting bracket at the front of the rack.**

- c. Using two Phillips 10-32 panhead screws, attach the front mounting bracket of one slide assembly to the front rail on the rack.
- d. Using two Phillips 10-32 panhead screws, attach the back (long) mounting bracket of the same slide assembly to the back rail of the rack (count the rack rail holes to ensure that you are matching the holes used on the front rail).

Do not tighten the screws as far as they will go yet, but tighten them so that the assemblies are secure.

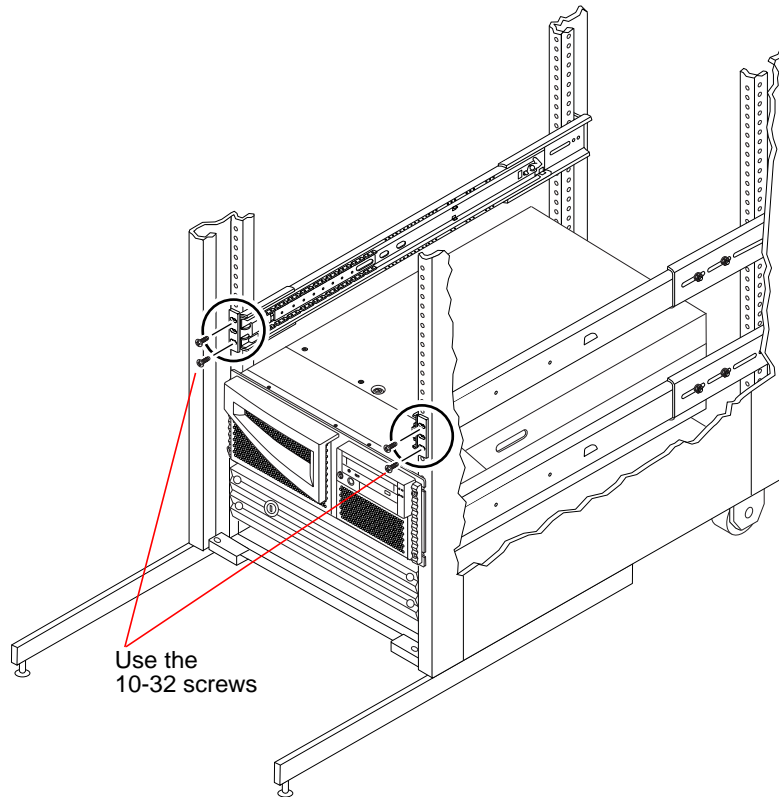

3. Tighten the four 8-32 lock nuts that secure the back mounting brackets to the slide assemblies.

Ensure that the back brackets are securely attached to each slide.

4. Push each slide assembly into the rack until each assembly is fully retracted into the rack enclosure.

Install the System Into the Rack Enclosure

1. Slide the ball-bearing runner forward until the dimple holds the runner in the forward position in each inner rail.



Caution – Ensure that each ball-bearing slide is secured at the *front* of each inner slide assembly before inserting any system into the slide assemblies. Verify that the inner slides are as far *back* as they can travel into the rack.

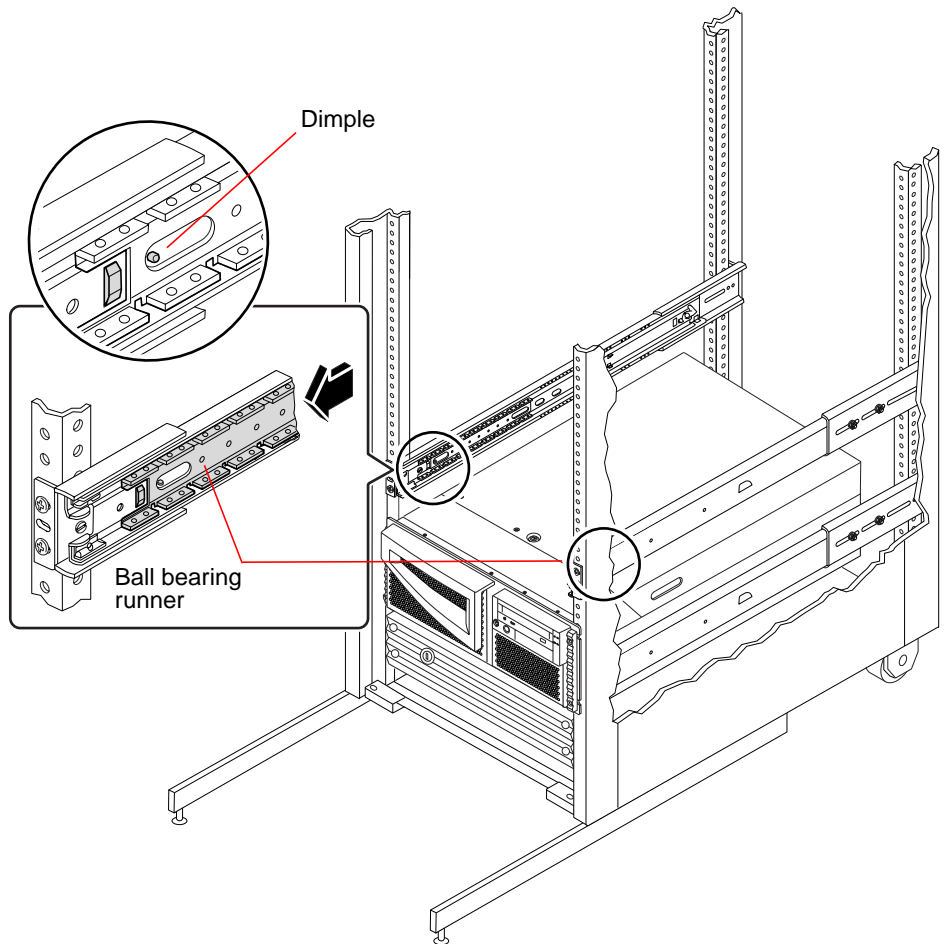



Caution – The system is heavy. Two persons are required to move the system.

2. Lift the server (one person on each side of the server) and approach the rack with the back of the server facing the front of the rack enclosure.
3. Align the crimped ends of the innermost glides on the server with the slide bracket assemblies in the rack enclosure.
4. Holding the server level, slide it evenly into the rack enclosure until the innermost glides stop in the slides.

The innermost glides are factory installed on the sides of the server enclosure.

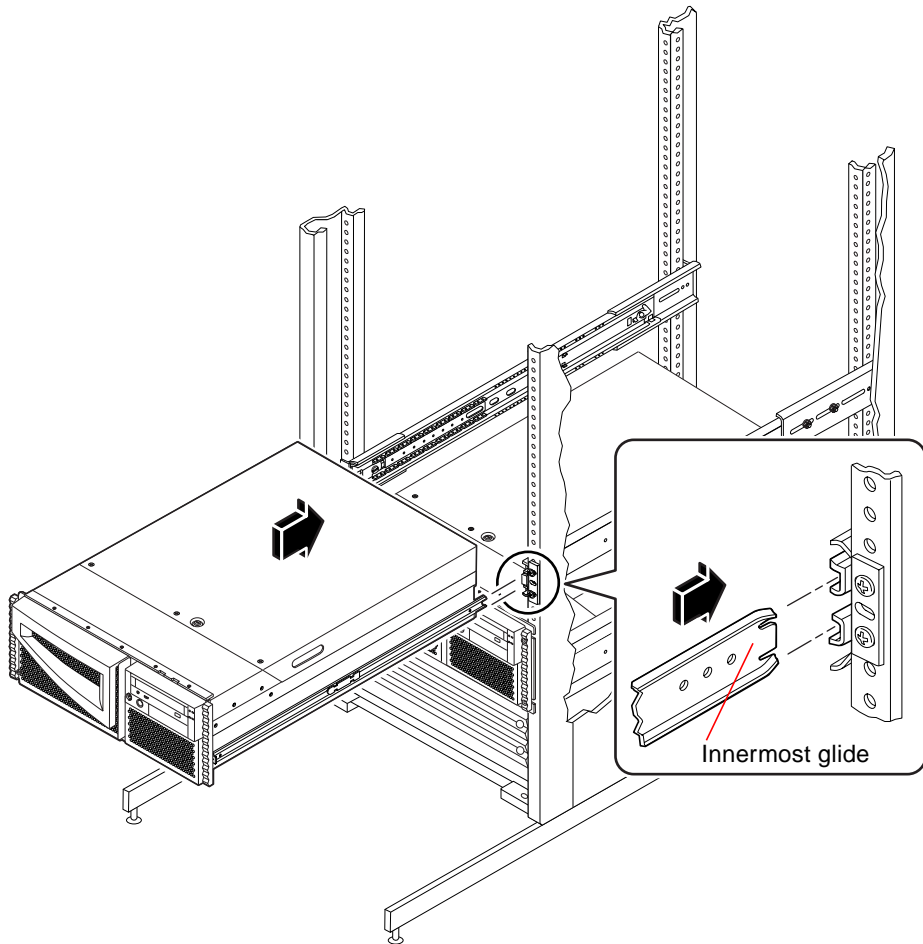

5. On each side of the enclosure, press the flat spring catch mounted on each innermost glide and slide the server all the way into the rack.

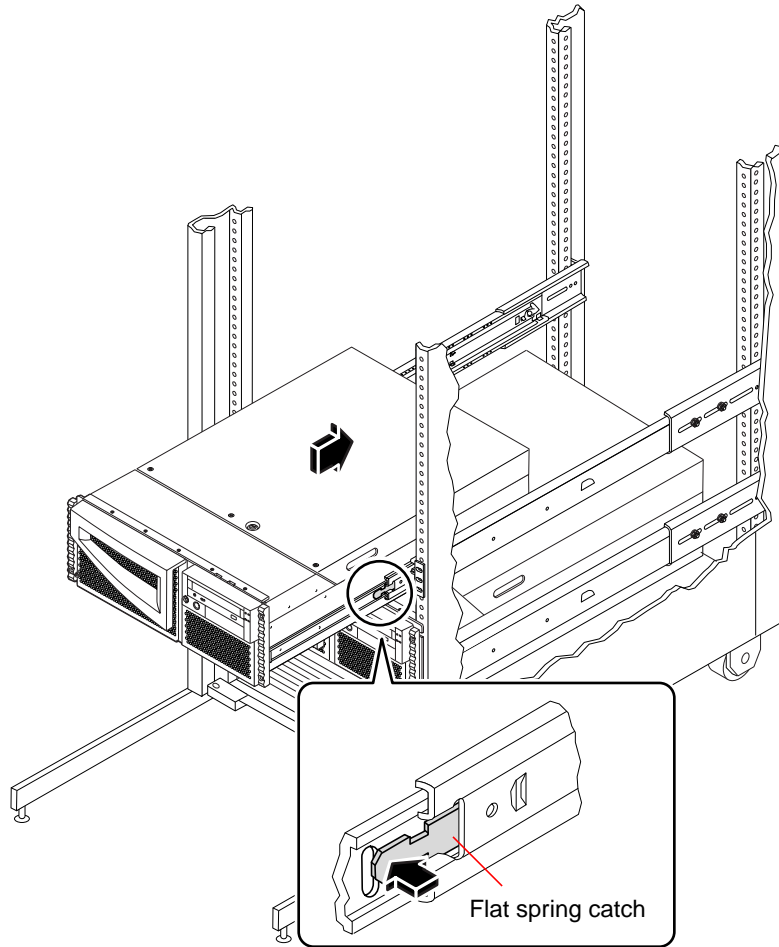

Tip – Slide the server in and out slowly and carefully to ensure that the slide assemblies and the innermost glides are working correctly.

6. Completely tighten all of the slide assembly rackmounting screws.
 - a. Make sure that the slide assemblies are level front-to-back and left-to-right.
 - b. Tighten the eight 10-32 screws that secure the slide assemblies to the vertical rack rails.

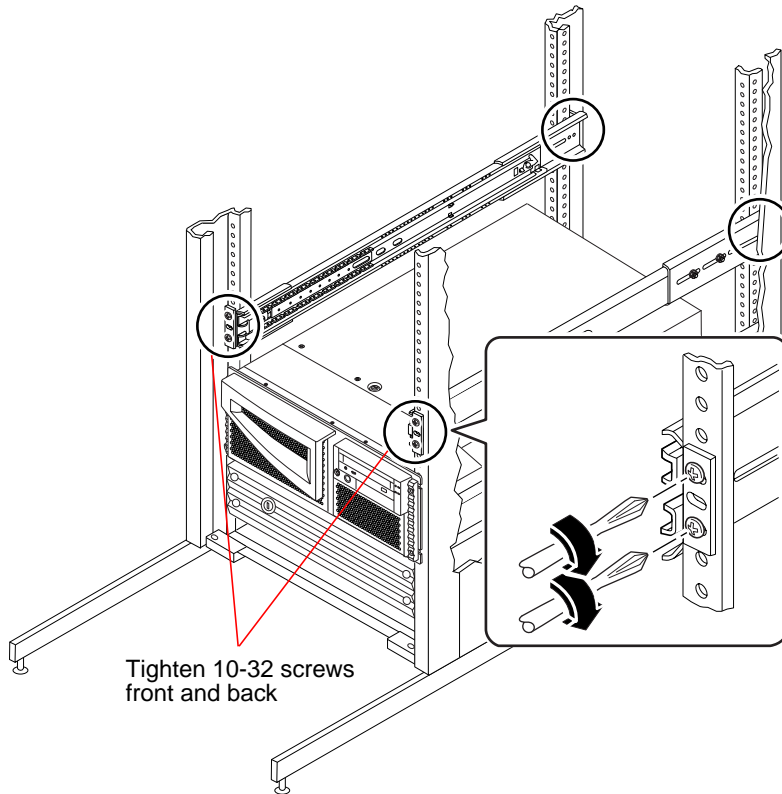

7. Secure the server to the rails.

Using the decorative panel retaining screws, secure the top and bottom of the system to the rails.

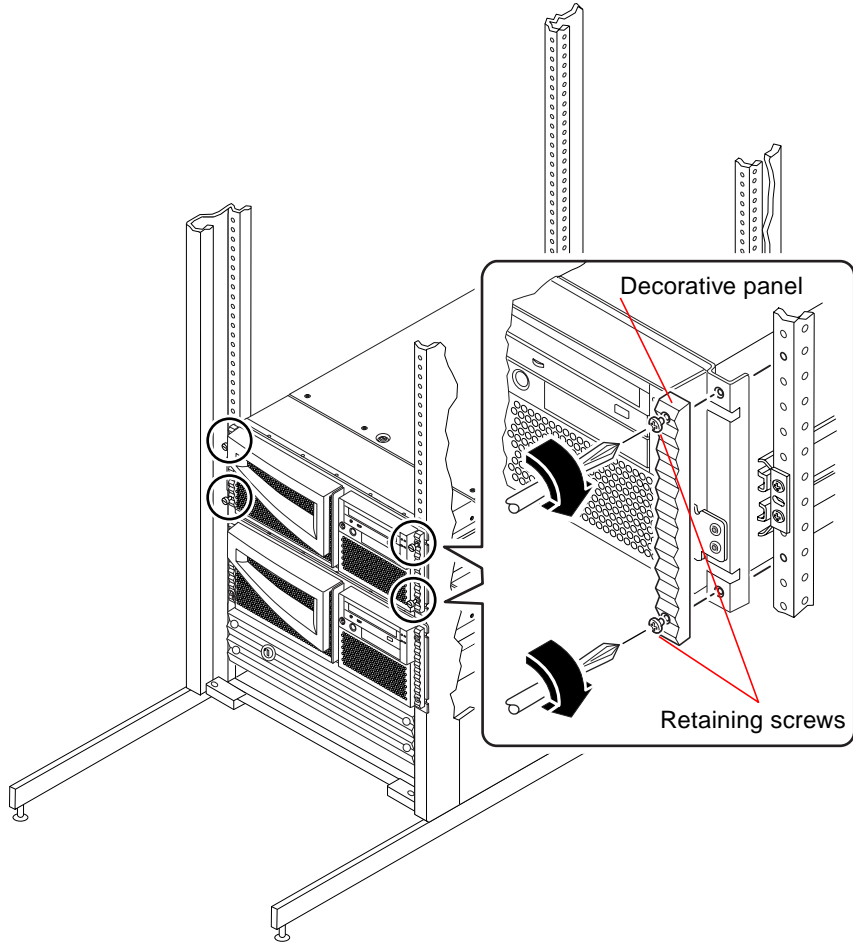

Setting Up the System

This chapter explains how to attach all the cords and cables needed to get the server up and running. Where software is involved, this chapter explains some of what you need to do, and points you to the appropriate software manuals for the rest of the information.

Complete the following tasks to finish setting up your system:

- “Connect the Power Cord” on page 20
- “Connect the Twisted-Pair Ethernet (TPE) Cable” on page 22
- “Install a System Console” on page 23
- “Restore the Rack Enclosure” on page 28
- “Power On the System” on page 28
- “Install the Operating System” on page 31
- “Install Online Documentation” on page 31

If you need to power off your system, see the *Sun Fire 280R Server Owner’s Guide*.

Connect the Power Cord

1. Turn the front panel keyswitch to the Off position.

Insert the system key into the keyswitch.

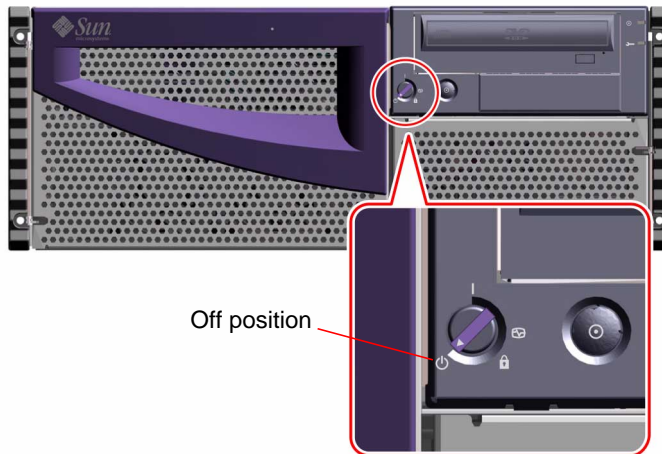

2. Connect the AC power cord to the right power inlet labeled AC-1 at the back of the system.

Connect the second AC power cord to the power inlet labeled AC-2 (if necessary).

3. Attach a strain relief to each AC power cord.

Use the strain relief to prevent accidental or inadvertent removal of an AC power cord from its inlet. The strain relief is a plastic tie-wrap and pedestal that is inserted into the back panel of the system. Use these reliefs to manage the power cords after you have installed the cords into the AC inlets in the server.

To use a strain relief, wrap the loose end of the tie-wrap around the AC power cord and thread the tie-wrap through the opening in the relief pedestal. Pull the end to tighten the tie-wrap.

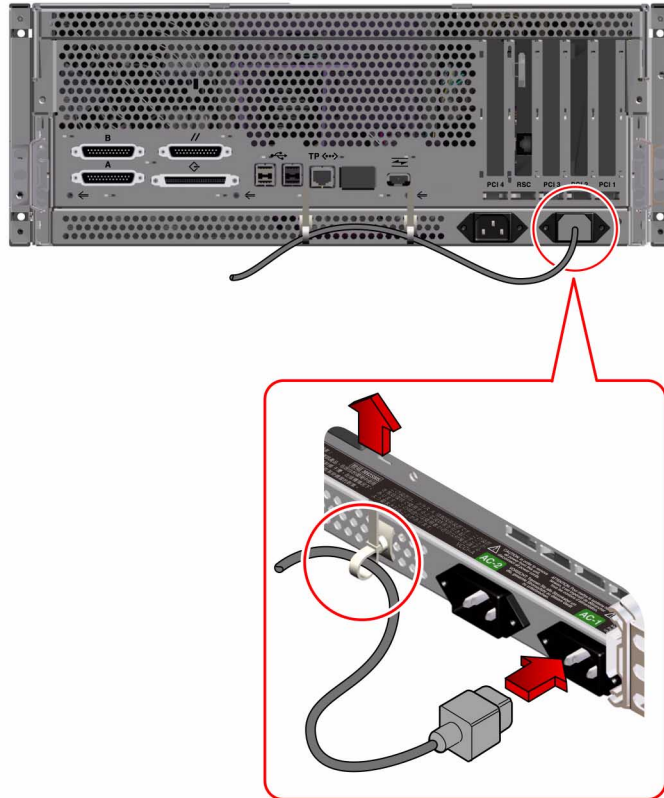

4. Connect the other end of the AC power cord to the power sequencer in the rack enclosure, or to an AC outlet.

See the instructions provided with your rack enclosure for information about the power sequencer. The outlet must connect the system to a 15A circuit in North America and Japan, and to a 10A circuit in Europe.

Note – You can connect the second power cord to the same AC circuit as the first supply. However, for increased system redundancy, connect the two power cords to separate circuits.

Connect the Twisted-Pair Ethernet (TPE) Cable

Connect the twisted-pair Ethernet (TPE) cable to the standard Ethernet port on the back of your system.

1. Connect the TPE cable to the RJ-45 connector on the server's back panel.

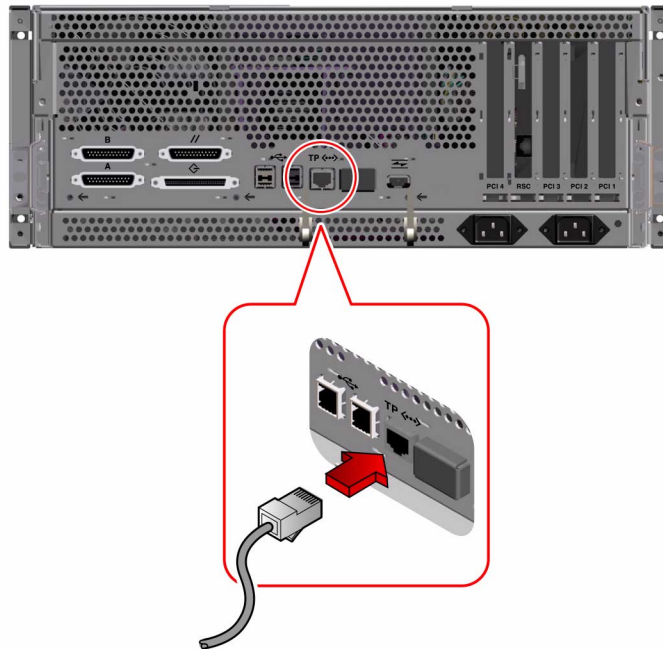

2. Connect the other end of the cable to the TPE outlet in the wall or the floor.

Install a System Console

To install the server software or to diagnose a problem, you need some way to enter system commands and view system output.

Configure the system using one of the following procedures:

- Establish a `tip` connection from another Sun system.
- Connect an ASCII terminal to serial port A.
- Install a graphics card, monitor, and keyboard on your server.

Note – The above components are not shipped with the server.

Set Up a `tip` Connection

For information about establishing a `tip` connection, see the *Sun Fire 280R Server Owner's Guide*.

Connect an ASCII Terminal

1. Connect the terminal's data cable to serial port A on the server's back panel.

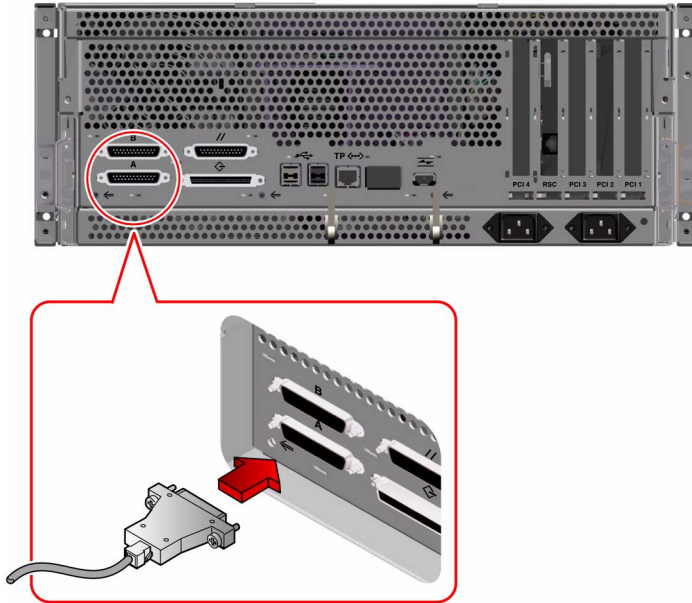

2. Connect the terminal's power cord to a grounded AC power outlet.

3. Set the terminal to receive:

- At 9600 baud
- An 8-bit signal with no parity and 1 stop bit

See the documentation accompanying your terminal for more information.

Install a Graphics Console

To install a local graphics console you need a Peripheral Component Interconnect (PCI)-based graphics card, a monitor, and a Sun Type 6 Universal Serial Bus (USB) keyboard, USB mouse and mouse pad. These components are not shipped with your system. See the *Sun Fire 280R Server Owner's Guide* for more information.

1. Install the graphics card into a vacant PCI slot.

For the procedure, see the *Sun Fire 280R Server Service Manual* or contact your qualified service provider.

2. Connect the monitor's video cable to the graphics card's video port.

Tighten the thumbscrews to secure the connection.

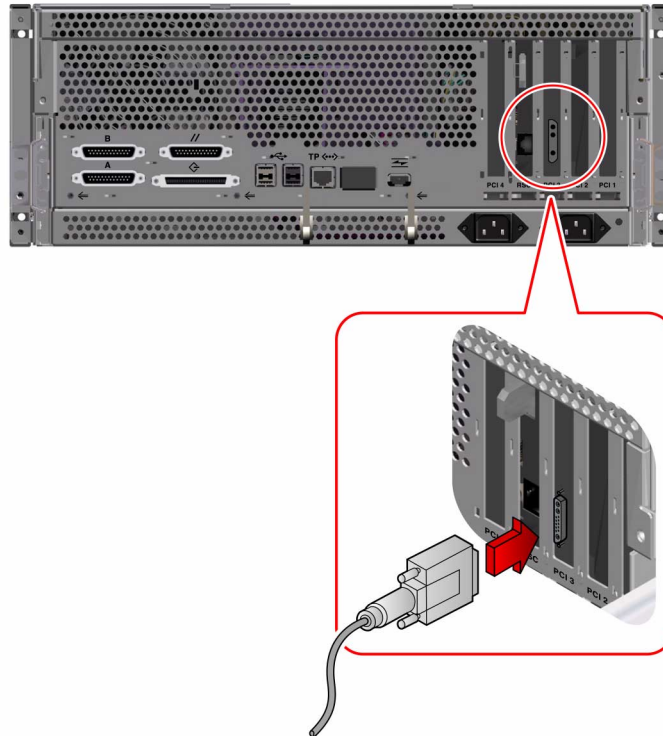

3. Connect the monitor's power cord to a grounded AC power outlet.

4. Connect the keyboard USB cable to a USB port on the back panel.

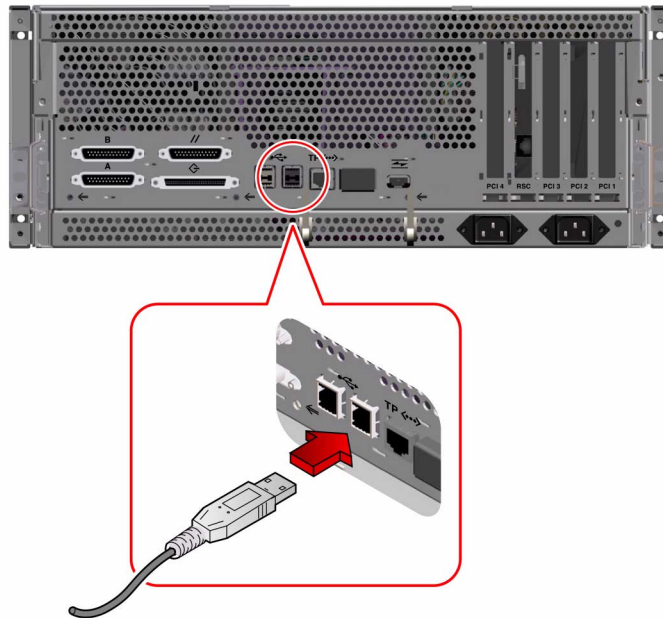

5. Connect the mouse USB cable to a USB port on the back panel.

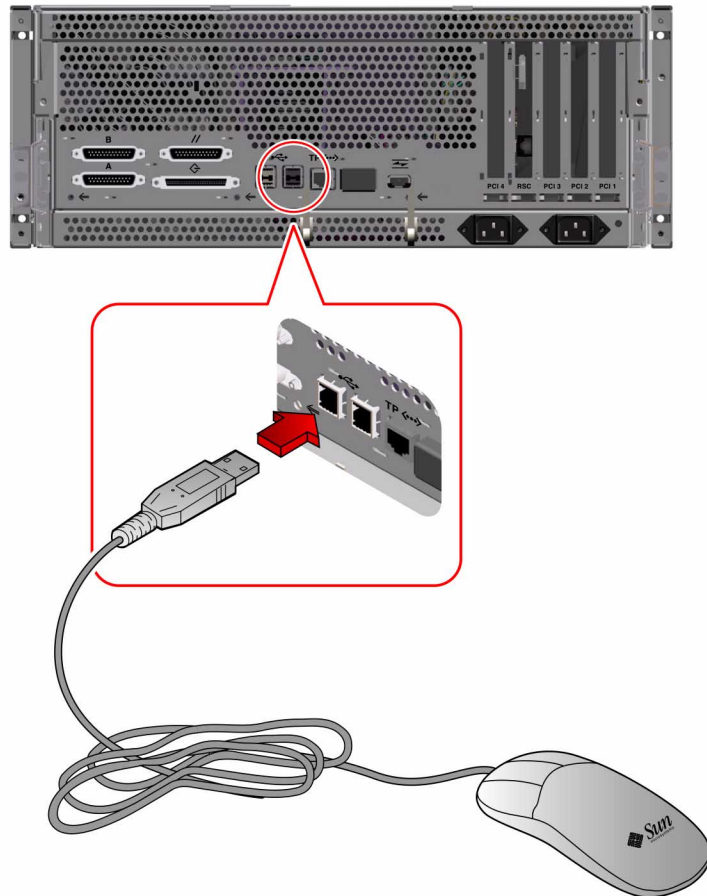

Restore the Rack Enclosure

See the instructions provided with your rack enclosure to complete these steps.

1. **Route and manage the AC cable and other cables within the rack enclosure.**
2. **Retract the enclosure's anti-tip legs, if applicable.**
3. **Replace the side panels, if applicable.**
4. **Replace the front and back doors, if applicable.**

Power On the System

You need the system key to perform this procedure.



Caution – Never move the system when the system power is on. Movement can cause catastrophic disk drive failure. Always power off the system before moving it.



Caution – Before you power on the system, make sure that the cover is properly installed.

1. **Turn on power to any peripheral and external storage devices.**
2. **Turn on power to the monitor or terminal, if applicable.**

3. Turn the front panel keyswitch to the Power-On/Off position.
Insert the system key into the keyswitch (if necessary).

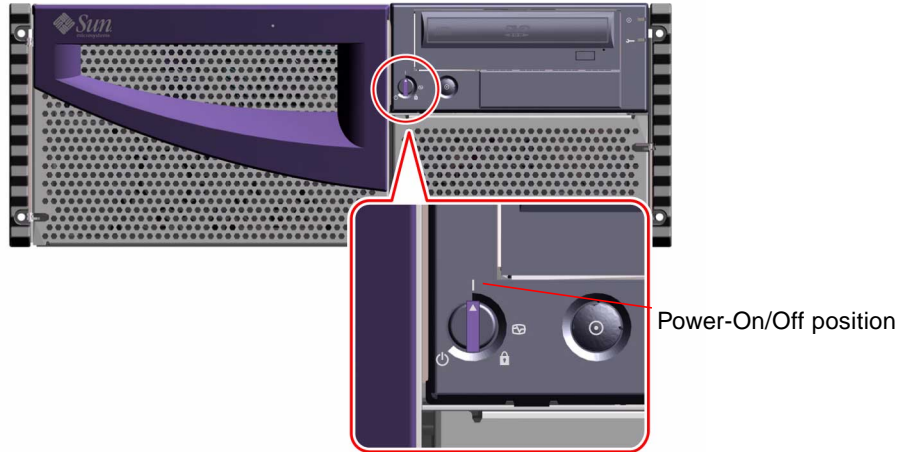

4. Press the front panel Power button once.

Note – The system may take anywhere from 30 seconds to two minutes before video is displayed on the graphics console, or the OK prompt appears on an attached terminal. This time depends on the level of power-on self-test (POST) diagnostics being performed.

5. Turn the keyswitch to the Locked position.

The Locked position prevents accidentally powering-off the system and locks the front doors.

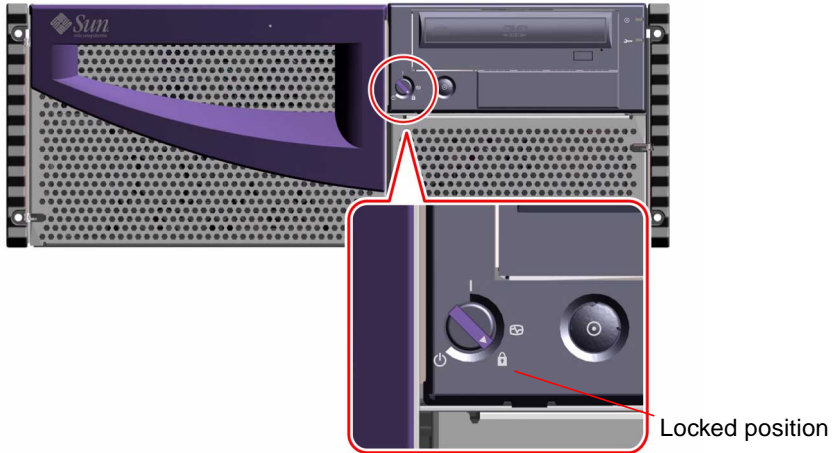

Note – If you need to power off the system, see the *Sun Fire 280R Server Owner's Guide* for more information.

6. Remove the key from the keyswitch, and keep it in a secure place.

Install the Operating System

If you are installing the Solaris 8 or later compatible operating environment, refer to the documentation accompanying your Solaris software and see the *Sun Fire 280R Server Owner's Guide* for installation information.

Install Online Documentation

The documentation kit contains a CD-ROM compatible disc with online documentation that describes how to use, service, and maintain your system. Refer to the documents supplied with the CD for installation instructions.

Rack Enclosure Requirements

The server is designed so that you can install it into a 72-inch (184-cm) tall Sun expansion cabinet or other EIA-compliant industry-standard rack enclosure that meets the requirements listed in the table below. You need a Sun rackmounting kit for each server that you will rackmount.

Rack Enclosure Feature	Requirement
Load Bearing Capacity	The rack must firmly support the weight of as many Sun Fire 280R servers as you are installing into the rack (each weighs up to 75 lb, 34 kg), plus the weight of the rackmounting hardware, and the weight of any other installed devices.
Vertical Space Requirements	Each server requires four rack units (7 inches, 17.78 cm) of vertical space for rack installation. A 72-inch (184-cm) cabinet can hold up to nine servers.
Airflow	<p>The system requires 113 cfm at 40° C and 10,000 feet. This airflow rate corresponds to 328 lb/hr at any altitude and to 78 cfm at 40° C and sea level.</p> <p>For proper ventilation, each system in the rack enclosure requires 28 square inches (181 square cm) of unrestricted airflow into the front of the system, and 23 square inches (148 square cm) of unrestricted exhaust port at the back of the system. Maintain a minimum 1.5 inches (3.8 cm) clearance between the system and any front or back doors.</p>

Rack Enclosure Feature	Requirement
Vertical Mounting Rail Requirements	<p>The rack must have two pairs of vertical mounting rails (one pair in front, one pair in back) that conform to the EIA (RETMA) standard for mounting hole spacing.</p> <p>Left-side-to-right-side rail spacing (mounting hole center to mounting hole center) for front and back rails must be 18.3 inches (46.5 cm).</p> <p>Front-to-back rail spacing must be at least 26.875 inches (68.26 cm) and not more than 34.875 inches (88.5 cm) from the outside face of the front rail to the outside face of the back rail.</p> <p>Front and back vertical rail mounting faces must be parallel with each other and with the front plane of the rack.</p>
Doors and Panels	<p>If you are using a Sun expansion cabinet, you can remove the front door and the side panels to increase access to the system. Otherwise, see the instructions provided with the rack enclosure.</p>
EMI Requirements	<p>Electromagnetic interference (EMI) shielding requirements are met by the system chassis and metal side panels, which remain in place when the unit is rackmounted.</p>
Anti-Tilt Protection	<p>The rack must be bolted securely to the floor or equipped with two sturdy and extendable anti-tip legs. You must prevent the cabinet from tilting forward when one or more systems or devices are fully extended out the front of the rack.</p>
Minimum Service Access	<p>An area not less than 3 feet (1 meter) deep and 6 feet (2 meters) wide must be available in front of the rack for installation and service access.</p> <p>When fully extended on its mounting rail slides, the system will protrude 29.75 inches (75.6 cm) forward of the rack's front vertical mounting rails.</p>
Fire Containment	<p>The rack enclosure must meet Underwriters Laboratories, Inc. and TUV Rheinland of N.A. requirements for fire containment.</p>