

Ultra™ Enterprise™ 450 Server and Sun™ Ultra™ 450 Workstation Rackmounting Guide



THE NETWORK IS THE COMPUTER™

Sun Microsystems Computer Company

A Sun Microsystems, Inc. Business
901 San Antonio Road
Palo Alto, CA 94303 USA
415 960-1300 fax 415 969-9131

Part No.: 805-1912-10
Revision B, October 1997

Copyright 1997 Sun Microsystems, Inc., 901 San Antonio Road • Palo Alto, CA 94303 USA. All rights reserved.

This product or document is protected by copyright and distributed under licenses restricting its use, copying, distribution, and decompilation. No part of this product or document may be reproduced in any form by any means without prior written authorization of Sun and its licensors, if any. Third-party software, including font technology, is copyrighted and licensed from Sun suppliers.

Parts of the product may be derived from Berkeley BSD systems, licensed from the University of California. UNIX is a registered trademark in the U.S. and other countries, exclusively licensed through X/Open Company, Ltd.

Sun, Sun Microsystems, the Sun logo, AnswerBook, SunDocs, Solaris, Ultra, and Ultra Enterprise are trademarks, registered trademarks, or service marks of Sun Microsystems, Inc. in the U.S. and other countries. All SPARC trademarks are used under license and are trademarks or registered trademarks of SPARC International, Inc. in the U.S. and other countries. Products bearing SPARC trademarks are based upon an architecture developed by Sun Microsystems, Inc.

The OPEN LOOK and Sun™ Graphical User Interface was developed by Sun Microsystems, Inc. for its users and licensees. Sun acknowledges the pioneering efforts of Xerox in researching and developing the concept of visual or graphical user interfaces for the computer industry. Sun holds a non-exclusive license from Xerox to the Xerox Graphical User Interface, which license also covers Sun's licensees who implement OPEN LOOK GUIs and otherwise comply with Sun's written license agreements.

RESTRICTED RIGHTS: Use, duplication, or disclosure by the U.S. Government is subject to restrictions of FAR 52.227-14(g)(2)(6/87) and FAR 52.227-19(6/87), or DFAR 252.227-7015(b)(6/95) and DFAR 227.7202-3(a).

DOCUMENTATION IS PROVIDED "AS IS" AND ALL EXPRESS OR IMPLIED CONDITIONS, REPRESENTATIONS AND WARRANTIES, INCLUDING ANY IMPLIED WARRANTY OF MERCHANTABILITY, FITNESS FOR A PARTICULAR PURPOSE OR NON-INFRINGEMENT, ARE DISCLAIMED, EXCEPT TO THE EXTENT THAT SUCH DISCLAIMERS ARE HELD TO BE LEGALLY INVALID.

Copyright 1997 Sun Microsystems, Inc., 901 San Antonio Road • Palo Alto, CA 94303 Etats-Unis. Tous droits réservés.

Ce produit ou document est protégé par un copyright et distribué avec des licences qui en restreignent l'utilisation, la copie, la distribution, et la décompilation. Aucune partie de ce produit ou document ne peut être reproduite sous aucune forme, par quelque moyen que ce soit, sans l'autorisation préalable et écrite de Sun et de ses bailleurs de licence, s'il y en a. Le logiciel détenu par des tiers, et qui comprend la technologie relative aux polices de caractères, est protégé par un copyright et licencié par des fournisseurs de Sun.

Des parties de ce produit pourront être dérivées des systèmes Berkeley BSD licenciés par l'Université de Californie. UNIX est une marque déposée aux Etats-Unis et dans d'autres pays et licenciée exclusivement par X/Open Company, Ltd.

Sun, Sun Microsystems, le logo Sun, AnswerBook, SunDocs, Solaris, Ultra, et Ultra Enterprise sont des marques de fabrique ou des marques déposées, ou marques de service, de Sun Microsystems, Inc. aux Etats-Unis et dans d'autres pays. Toutes les marques SPARC sont utilisées sous licence et sont des marques de fabrique ou des marques déposées de SPARC International, Inc. aux Etats-Unis et dans d'autres pays. Les produits portant les marques SPARC sont basés sur une architecture développée par Sun Microsystems, Inc.

L'interface d'utilisation graphique OPEN LOOK et Sun™ a été développée par Sun Microsystems, Inc. pour ses utilisateurs et licenciés. Sun reconnaît les efforts de pionniers de Xerox pour la recherche et le développement du concept des interfaces d'utilisation visuelle ou graphique pour l'industrie de l'informatique. Sun détient une licence non exclusive de Xerox sur l'interface d'utilisation graphique Xerox, cette licence couvrant également les licenciés de Sun qui mettent en place l'interface d'utilisation graphique OPEN LOOK et qui en outre se conforment aux licences écrites de Sun.

CETTE PUBLICATION EST FOURNIE "EN L'ETAT" ET AUCUNE GARANTIE, EXPRESSE OU IMPLICITE, N'EST ACCORDEE, Y COMPRIS DES GARANTIES CONCERNANT LA VALEUR MARCHANDE, L'APTITUDE DE LA PUBLICATION A REpondre A UNE UTILISATION PARTICULIERE, OU LE FAIT QU'ELLE NE SOIT PAS CONTREFAISANTE DE PRODUIT DE TIERS. CE DENI DE GARANTIE NE S'APPLIQUERAIT PAS, DANS LA MESURE OU IL SERAIT TENU JURIDIQUEMENT NUL ET NON AVENU.



Contents

Preface v

**1. How to Rackmount the Ultra Enterprise 450 Server
or Sun Ultra 450 Workstation** 1

Inventory 2

Installing the Rack Handle and Rear Bracket 3

Installing the Tray and Slide Assemblies 4

Installing the Chassis 8

Preface

The *Ultra Enterprise 450 Server and Sun Ultra 450 Workstation Rackmounting Guide* shows you how to install your system in a Sun™ system or expansion cabinet, or other EIA-compliant rack enclosure.

Related Documents

The following documents contain topics that relate to the information in this guide:

- *Ultra Enterprise Expansion Cabinet Installation and Service Manual*
- *56-Inch Data Center Expansion Cabinet Installation Manual*
- *Ultra Enterprise 450 Server Owner's Guide*
- *Sun Ultra 450 Workstation Owner's Guide*

Ordering Sun Documents

SunDocsSM is a distribution program for Sun Microsystems technical documentation. Contact SunExpress for easy ordering and quick delivery. You can find a listing of available Sun documentation on the World Wide Web.

TABLE P-1 SunExpress Contact Information

Country	Telephone	Fax
Belgium	02-720-09-09	02-725-88-50
Canada	1-800-873-7869	1-800-944-0661
France	0800-90-61-57	0800-90-61-58
Germany	01-30-81-61-91	01-30-81-61-92
Holland	06-022-34-45	06-022-34-46
Japan	0120-33-9096	0120-33-9097
Luxembourg	32-2-720-09-09	32-2-725-88-50
Sweden	020-79-57-26	020-79-57-27
Switzerland	0800-55-19-26	0800-55-19-27
United Kingdom	0800-89-88-88	0800-89-88-87
United States	1-800-873-7869	1-800-944-0661

World Wide Web: <http://www.sun.com/sunexpress/>

Sun Documentation on the Web

The `docs.sun.com` web site enables you to access Sun technical documentation on the World Wide Web. You can browse the `docs.sun.com` archive or search for a specific book title or subject at <http://docs.sun.com>.

Sun Welcomes Your Comments

We are interested in improving our documentation and welcome your comments and suggestions. You can email your comments to us at smcc-docs@sun.com. Please include the part number of your document in the subject line of your email.

How to Rackmount the Ultra Enterprise 450 Server or Sun Ultra 450 Workstation



Caution – The chassis is heavy. In the following procedures, two people are required to move the chassis. Two people are also required to align and install the rackmount tray and slide assemblies in the rack.

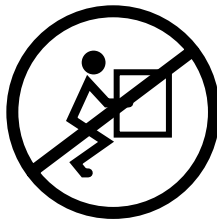

Caution – Install the chassis as low as possible in the rack enclosure. For best stability, do not install the chassis above equipment that weighs less than it does.



Caution – For proper ventilation, each Ultra™ Enterprise™ 450 server or Sun™ Ultra™ 450 workstation in the rack enclosure requires 92 square inches (593 square cm) of unrestricted airflow into the front of the system, and 97 square inches (626 square cm) of unrestricted exhaust port at the rear of the system. Maintain a minimum 1.5 inches (3.8 cm) clearance between the system and any front or rear doors.

Inventory

The rack-mounting kit contains the following parts.

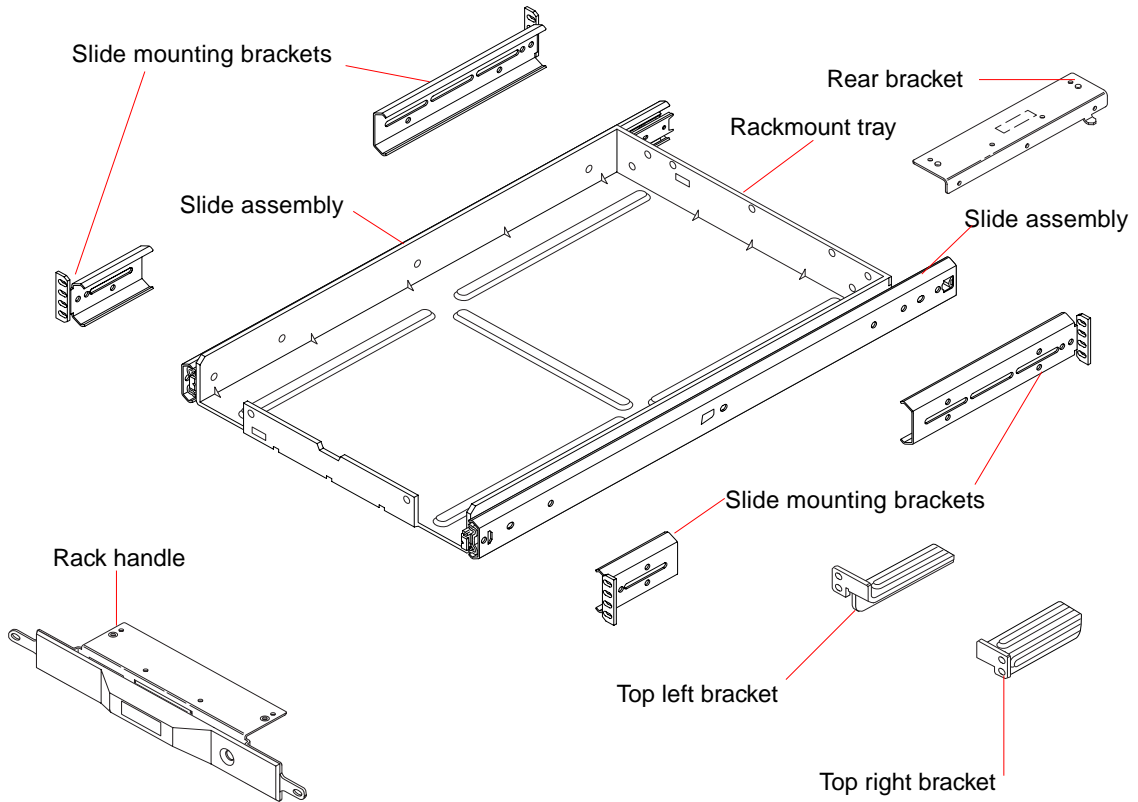

The rack-mounting kit also contains the following screws, washers, and nuts, shown actual size.

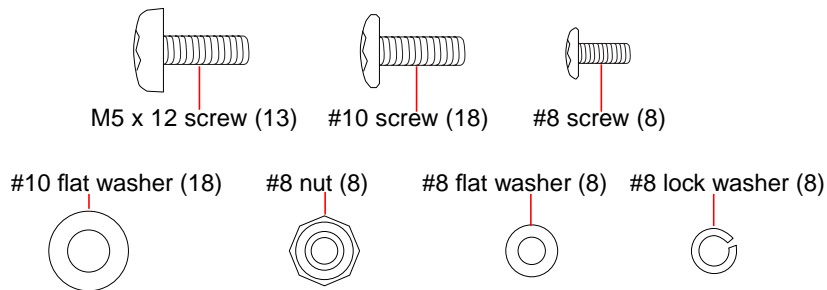

Installing the Rack Handle and Rear Bracket

1. **Disconnect all cables from the Ultra Enterprise 450 server or Sun Ultra 450 workstation chassis.**
2. **Carefully turn the chassis onto its left side.**

Do not lift the chassis using the plastic parts at the front of the chassis, or the side panels where they overhang at the rear.

Roll the system onto a solid surface that spaces the unit about 2 inches (5 cm) off the floor; for example, use a pair of wooden boards. Do not allow any of the weight to rest on the plastic parts at the front of the chassis.

- 3. Install the rack handle and rear bracket onto the chassis bottom, as shown below.**
Use four M5 x 12 screws for each bracket.

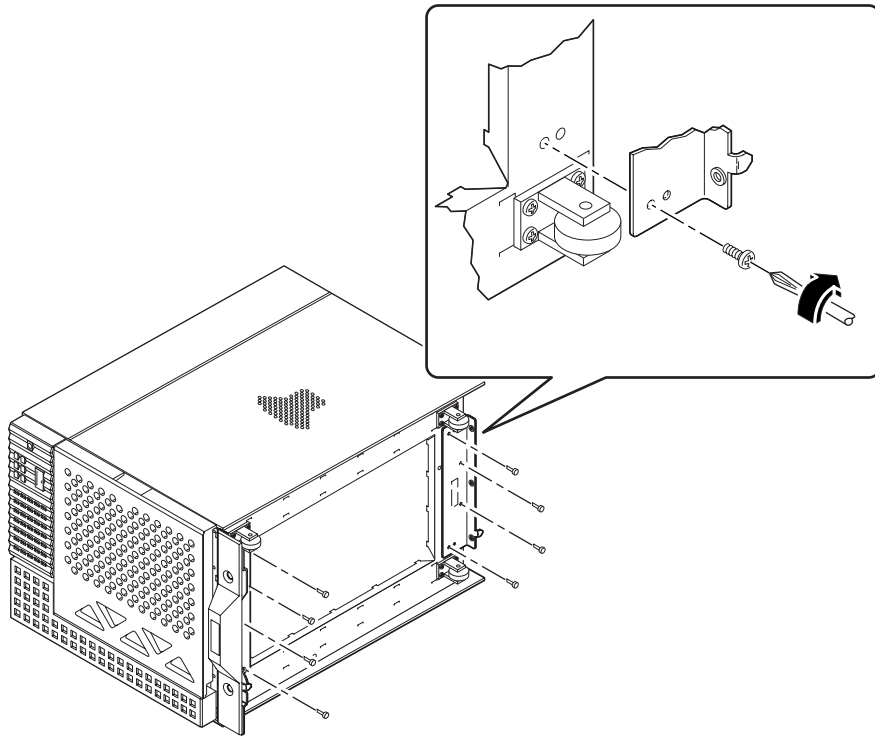

Installing the Tray and Slide Assemblies

- 1. Remove the front door of the cabinet.**
- For a Sun expansion cabinet, lift the door off the hinge pins.
 - For a Sun server cabinet, pull off the front panel, then lift the door.

2. Extend the slides fully.

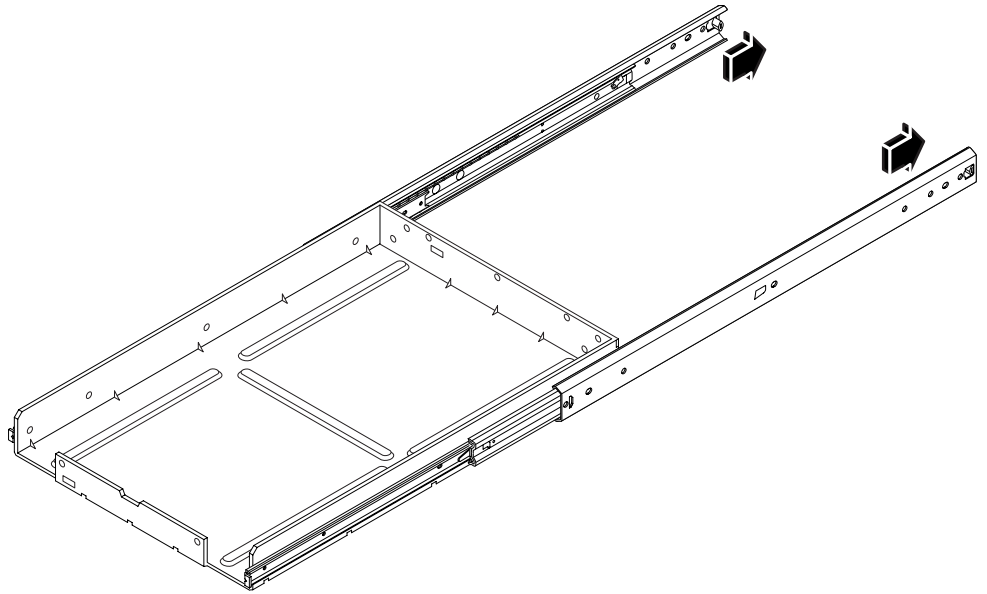

3. Attach one short slide mounting bracket to the front and one long slide mounting bracket to the rear of each slide.

Use two #8 screws, flat washers, lock washers, and nuts for each bracket. Use screw holes appropriate for the depth of the cabinet.

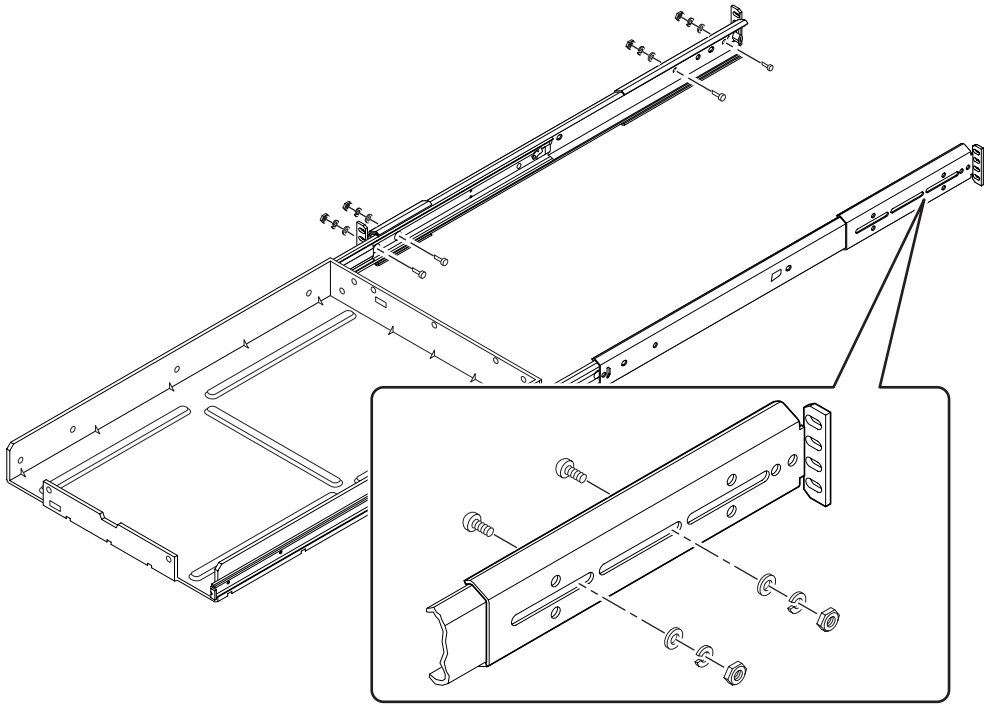

4. Attach the front and rear slide mounting brackets for each slide to the rack mounting rails, using #10 screws and flat washers.

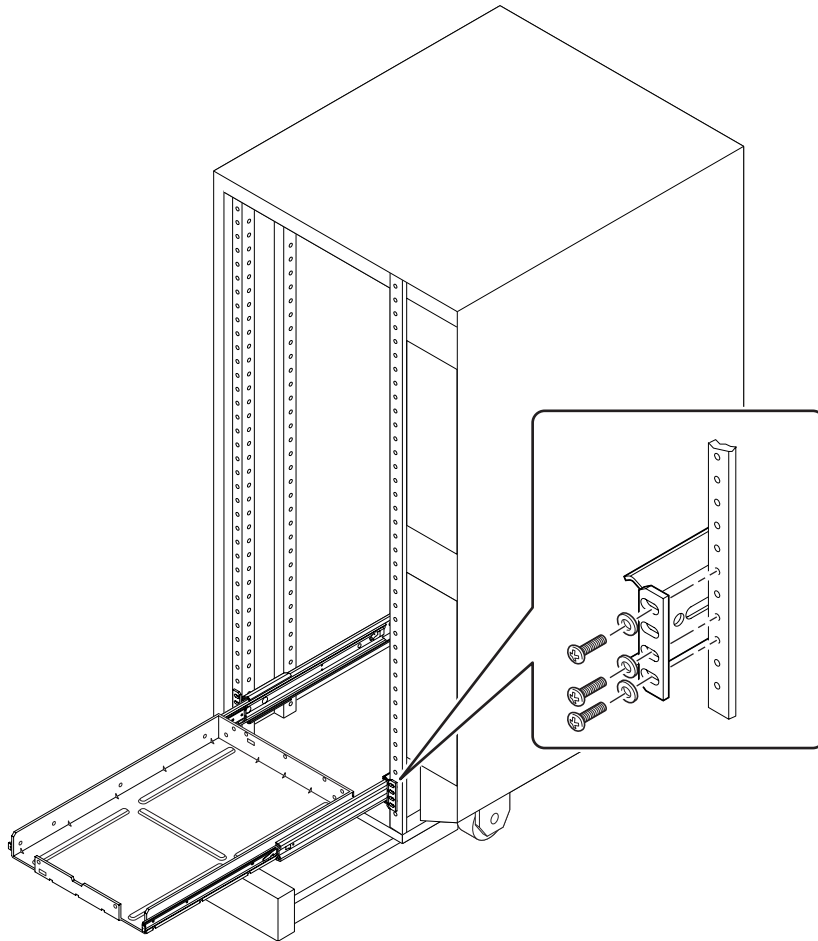

Do not tighten the screws completely at this time. Be sure to use the correct positions in the rack. Locate each bracket with the bottom edge centered between the lowest 5/8-inch (1.6 cm) spacing on the rail. To mount the unit in an EIA standard rack, allow 14 unit spaces. To mount two units, allow 28 unit spaces.

Use a level to ensure that the rackmount tray is level front-to-back and left-to-right. Also, make sure that the rackmount tray is centered precisely between the left and right walls of the rack enclosure. This will ensure that the system chassis, when installed, slides freely within the rack enclosure without interference.

After leveling and centering the rackmount tray, tighten the front and rear bracket screws completely.

Installing the Chassis

1. Turn the chassis right side up.

Do not lift the chassis using the side panels or the plastic parts at the front of the chassis.

2. Extend the stabilizer legs and lower the leveling pads to ensure that the cabinet cannot move or tip forward when the rackmount tray is extended.



Caution – If your rack enclosure does not have stabilizer legs, secure it sufficiently to support the total weight of the system when it is fully extended.

3. Lift the chassis and position it on the tray assembly.

Alternatively, you can set the rear wheels on the tray assembly and then roll the unit into position.

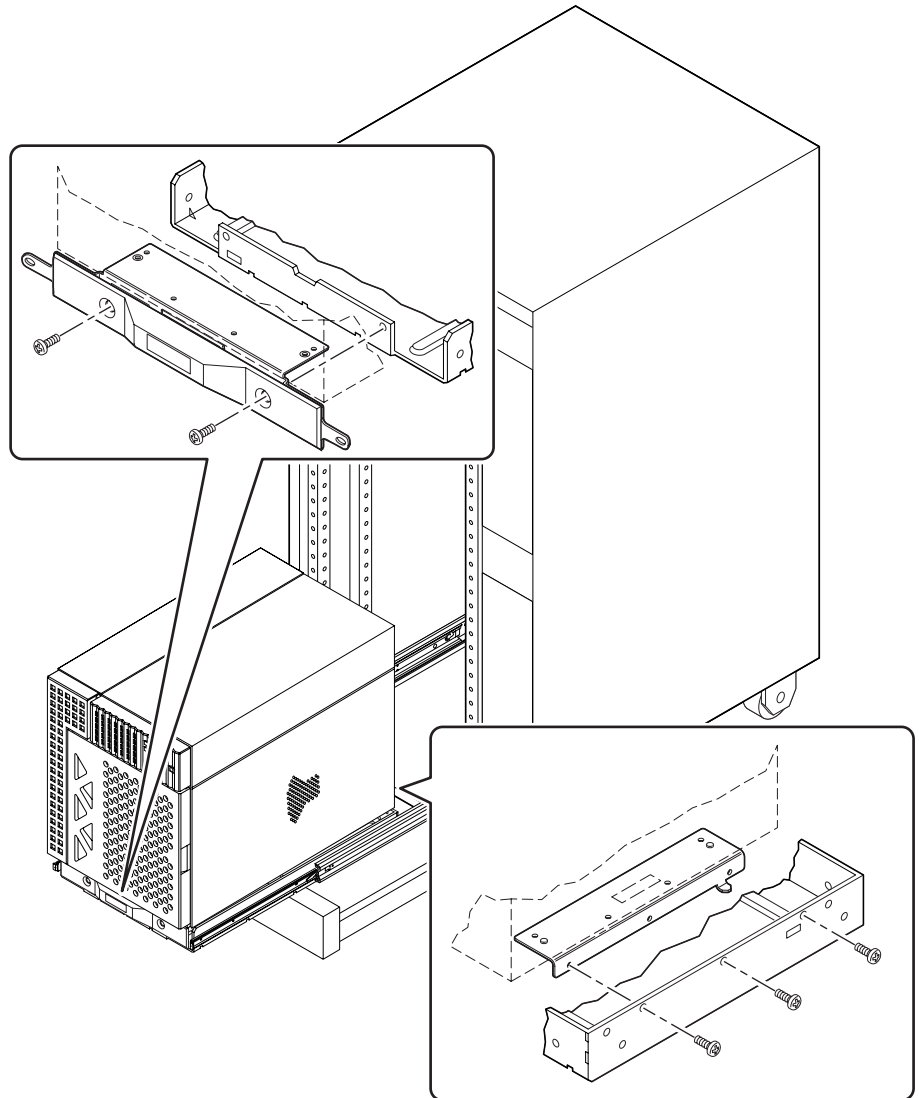

4. Secure the system chassis to the tray assembly using five M5 x 12 mm screws.

Use two screws for the rack handle at the front of the chassis and three screws for the rear bracket.

- 5. Press the locking mechanism on each slide and slide the system all the way to the rear of the enclosure.**

The levers for the left and right sides operate in opposite directions.

Check that the system is installed in the rack level and centered, so that it does not rub against the rails. Adjust if necessary, and retighten the screws.

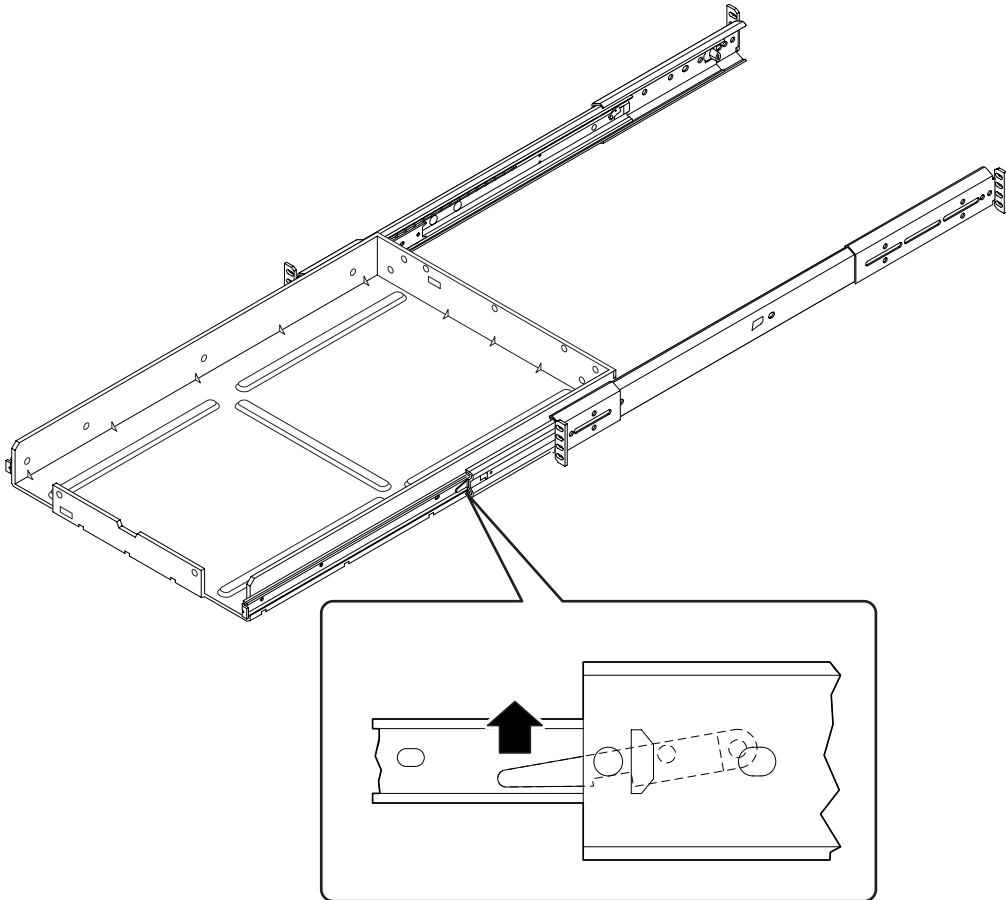

- 6. Secure the rackmount handle to the rack rails using two #10 screws and flat washers, as shown in the next figure.**

These screws secure the system inside the rack. To service the system, remove these screws and washers from the rackmount handle and slide the system out of the rack on its rails. After service is completed, slide the system all the way to the rear of the enclosure and reinstall the screws and washers.

7. Install the right and left top brackets using #10 screws and flat washers.

Install the brackets so that they are as close as possible to the top edges of the system; choose the closest holes in the rack that line up for this purpose. For each bracket, use two screws at the front of the cabinet.

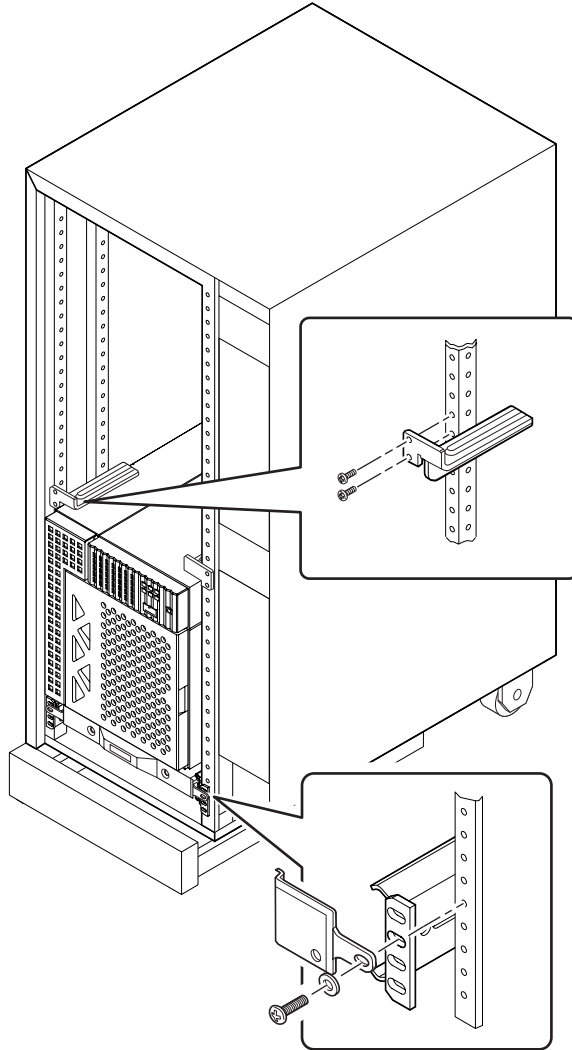

8. If your rack has stabilizing legs, raise the leveling pads and retract the stabilizer legs.

9. Connect the chassis to the power sequencer.

See instructions supplied with the rackmount enclosure.

10. Route data cables as appropriate and connect them to the chassis.

11. Install the rack front door or front panels.

However, if the front door or front panels do not meet the airflow requirements on page 1, do not install them.