



# Sun Blade™ X6440 Server Module Installation Guide

---

Sun Microsystems, Inc.  
[www.sun.com](http://www.sun.com)

Part No. 820-3961-11, Rev. A  
August 2009

Submit comments about this document by clicking the Feedback[+] link at: <http://docs.sun.com>

Copyright © 2009 Sun Microsystems, Inc., 4150 Network Circle, Santa Clara, California 95054, U.S.A. All rights reserved.

Sun Microsystems, Inc. has intellectual property rights relating to technology embodied in the product that is described in this document. In particular, and without limitation, these intellectual property rights may include one or more of the U.S. patents listed at <http://www.sun.com/patents> and one or more additional patents or pending patent applications in the U.S. and in other countries.

Parts of the product may be derived from Berkeley BSD systems, licensed from the University of California. UNIX is a registered trademark in the U.S. and in other countries, exclusively licensed through X/Open Company, Ltd.

Sun, Sun Microsystems, the Sun logo, Java, Solaris, OpenSolaris, Sun Blade, docs.sun.com, Sun Fire and the Solaris logo are trademarks or registered trademarks of Sun Microsystems, Inc., or its subsidiaries, in the U.S. and other countries.

Microsoft is a trademark or registered trademark of Microsoft Corporation or its subsidiaries in the United States and Other countries. Windows is a trademark or registered trademark of Microsoft Corporation or its subsidiaries in the United States and Other countries. The Adobe logo is a registered trademark of Adobe Systems, Incorporated.

Use of any spare or replacement CPUs is limited to repair or one-for-one replacement of CPUs in products exported in compliance with U.S. export laws. Use of CPUs as product upgrades unless authorized by the U.S. Government is strictly prohibited.

DOCUMENTATION IS PROVIDED "AS IS" AND ALL EXPRESS OR IMPLIED CONDITIONS, REPRESENTATIONS AND WARRANTIES, INCLUDING ANY IMPLIED WARRANTY OF MERCHANTABILITY, FITNESS FOR A PARTICULAR PURPOSE OR NON-INFRINGEMENT, ARE DISCLAIMED, EXCEPT TO THE EXTENT THAT SUCH DISCLAIMERS ARE HELD TO BE LEGALLY INVALID.

---

Copyright © 2009 Sun Microsystems, Inc., 4150 Network Circle, Santa Clara, California 95054, Etats-Unis. Tous droits réservés.

Sun Microsystems, Inc. détient les droits de propriété intellectuelle relatifs à la technologie incorporée dans le produit qui est décrit dans ce document. En particulier, et ce sans limitation, ces droits de propriété intellectuelle peuvent inclure un ou plus des brevets américains listés à l'adresse <http://www.sun.com/patents> et un ou les brevets supplémentaires ou les applications de brevet en attente aux Etats - Unis et dans les autres pays.

Des parties de ce produit pourront être dérivées des systèmes Berkeley BSD licenciés par l'Université de Californie. UNIX est une marque déposée aux Etats-Unis et dans d'autres pays et licenciée exclusivement par X/Open Company, Ltd.

Sun, Sun Microsystems, le logo Sun, Java, Solaris, OpenSolaris, Sun Blade, docs.sun.com, Sun Fire et le logo Solaris sont des marques de fabrique ou des marques déposées de Sun Microsystems, Inc., ou ses filiales, aux Etats-Unis et autres pays.

Microsoft sont est marques de fabrique ou des marques déposées de Microsoft Corporation ou de sa filiale aux Etats-Unis et dans d'autres pays. Windows est une marque de fabrique ou une marques déposée de Microsoft Corporation ou de sa filiale aux Etats-Unis et dans d'autres pays. Le logo Adobe est une marque déposée de Adobe Systems, Incorporated.

L'utilisation de pieces detachees ou d'unités centrales de remplacement est limitee aux reparations ou a l'echange standard d'unités centrales pour les produits exportes, conformément a la legislation americaine en matiere d'exportation. Sauf autorisation par les autorites des Etats-Unis, l'utilisation d'unités centrales pour proceder a des mises a jour de produits est rigoureusement interdite.

LA DOCUMENTATION EST FOURNIE "EN L'ETAT" ET TOUTES AUTRES CONDITIONS, DECLARATIONS ET GARANTIES EXPRESSES OU TACITES SONT FORMELLEMENT EXCLUES, DANS LA MESURE AUTORISEE PAR LA LOI APPLICABLE, Y COMPRIS NOTAMMENT TOUTE GARANTIE IMPLICITE RELATIVE A LA QUALITE MARCHANDE, A L'APTITUDE A UNE UTILISATION PARTICULIERE OU A L'ABSENCE DE CONTREFAÇON.



# Contents

---

**Preface**   vii

- 1. Installing the Server Hardware**   1
  - Before You Begin   2
    - Terms Used in This Guide   2
  - Installation Overview   3
  - Installing the Server Module   4
    - Installing the Compact Flash Card   4
      - ▼ To Install the CF Card   4
    - Inserting the Server Module   5
      - ▼ To Insert the Server Module   5
    - Placing the Server in Standby Power Mode   7
  - Powering On the Server Module   9
    - ▼ To Power On the Server Module   9
  - Powering Off the Server Module   9
    - ▼ To Power Off the Server Module   9
  - Booting the Server Module   9
  - Removing the Compact Flash Card   10
    - ▼ To Remove the CF Card   10

<b>2. Setting Up the Server Software</b>	<b>13</b>
Integrated Lights Out Manager	13
What Is a Service Processor?	14
About the Preconfigured Administrator Account	14
ILOM Connection Overview	15
Connecting to the Server Module ILOM	15
Option 1: Connecting to ILOM Through the Chassis Serial Connector	16
▼ To Connect to ILOM Through the Chassis Serial Connector	16
Option 2: Connecting to ILOM Through a Dongle Cable	20
▼ To Connect to ILOM Using a Dongle Cable	21
Option 3: Connecting to ILOM Through the Ethernet Port	21
Logging In and Out of ILOM	22
▼ To Log In and Out of the ILOM CLI	22
▼ To Log In and Out of the ILOM Web GUI	22
Configuring the ILOM IP Address	25
▼ To View the ILOM IP Address	25
▼ To Configure the ILOM IP Address Using BIOS Setup Utility	25
▼ To Configure the ILOM IP Address Using DHCP	27
▼ To Configure the ILOM IP Address Using the CLI	28
Customizing the Sun Blade X6440 Server Module's ILOM	31
Setting Up Platform Operating System and Driver Software	31
<b>3. Configuring the Preinstalled Solaris 10 Operating System</b>	<b>33</b>
Before You Begin	34
Installation Worksheet	34
Configuring the Preinstalled Solaris 10 Operating System	38
▼ To Configure the Preinstalled Solaris 10 OS	38
▼ (Optional) To Redirect the Console Output to the Video Port	40
Solaris 10 Operating System User Information	40

Solaris 10 User Documentation	41
Solaris 10 OS Training	41
Using the Solaris Installation Program	41
Sun Java Enterprise System	41
Sun Studio 11	42
Reinstalling the Solaris Operating System	42
Downloading the Solaris Operating System	42
<b>4. Configuring the Preinstalled OpenSolaris Operating System</b>	<b>43</b>
Before You Begin	44
Installation Worksheet	44
Configuring the Preinstalled OpenSolaris Operating System	48
▼ To Configure the Preinstalled OpenSolaris OS	48
▼ (Optional) To Redirect the Console Output to the Video Port	50
▼ To Modify the GRUB Menu to Auto Boot	50
Getting Started With the OpenSolaris Operating System	51
OpenSolaris Operating System User Information	52
OpenSolaris OS User Documentation	52
OpenSolaris OS Training	52
Using the OpenSolaris Installation Program	52
Reinstalling the OpenSolaris Operating System	53
Downloading the OpenSolaris Operating System	53
<b>Index</b>	<b>55</b>



# Preface

---

This *Sun Blade X6440 Server Module Installation Guide* contains procedures for installing the server module in a chassis, connecting to the service processor, and configuring either the preinstalled Solaris™ Operating System, or the preinstalled OpenSolaris™ Operating System.

---

## Using UNIX Commands

This document might not contain information about basic UNIX® commands and procedures such as shutting down the system, booting the system, and configuring devices. Refer to the following for this information:

- Software documentation that you received with your system
- Solaris Operating System documentation, which is at <http://docs.sun.com/>

---

# Shell Prompts

Shell	Prompt
C shell	<i>machine-name%</i>
C shell superuser	<i>machine-name#</i>
Bourne shell and Korn shell	\$
Bourne shell and Korn shell superuser	#

---

# Typographic Conventions

Typeface*	Meaning	Examples
AaBbCc123	The names of commands, files, and directories; onscreen computer output	Edit your <code>.login</code> file. Use <code>ls -a</code> to list all files. % You have mail.
<b>AaBbCc123</b>	What you type, when contrasted with onscreen computer output	% <b>su</b> Password:
<i>AaBbCc123</i>	Book titles, new words or terms, words to be emphasized. Replace command-line variables with real names or values.	Read Chapter 6 in the <i>User's Guide</i> . These are called <i>class</i> options. You <i>must</i> be superuser to do this. To delete a file, type <code>rm filename</code> .

\* The settings on your browser might differ from these settings.

---

# Related Documentation

The documents listed in the following table are available online at:

<http://docs.sun.com>

At that site, search for the Sun Blade™ X6440 Server Module.



---

**Note** – The last two digits of the documentation part number identify the latest version of the product documentation that is available for download (or viewing online). For example: 820-xxxx-XX.

---

<b>Title</b>	<b>Content</b>	<b>Part Number</b>	<b>Format</b>
<i>Sun Blade X6440 Server Module Product Notes</i>	Late-breaking information about the server module.	820-3965	PDF HTML
<i>Sun Blade X6440 Server Module Getting Started Guide</i>	Basic installation information for setting up the server module.	820-3960	PDF Print
<i>Sun Blade X6440 Server Module Installation Guide</i>	Detailed installation information for setting up the server module.	820-3961	PDF HTML Print option
<i>Sun Blade X6440 Server Module Operating System Installation Guide</i>	Installation instructions for the Solaris and Linux operating systems.	820-3962	PDF HTML
<i>Sun Blade X6440 Server Module Windows Operating System Installation Guide</i>	Installation instructions for the Windows Server operating system.	820-3963	PDF HTML
<i>Sun Blade X6440 Server Module Service Manual</i>	Information and procedures for maintaining and upgrading the server module.	820-3964	PDF HTML
<i>Sun Integrated Lights Out Manager 2.0 User's Guide</i>	ILOM features and tasks that are common to servers and server modules that support ILOM.	820-1188	PDF HTML
<i>Sun Integrated Lights Out Manager Supplement for Sun Blade X6440 Server Module</i>	ILOM information that is specific to the server module.	820-3967	PDF HTML
<i>Sun Blade X6440 Server Module Safety and Compliance Manual</i>	Hardware safety and compliance information for the server module.	820-4412	PDF
<i>Important Safety Information for Sun Hardware Systems</i>	Multilingual hardware safety and compliance information for all Sun hardware systems.	816-7190	Print

---

---

## Support and Training

Sun Function	URL
Support	<a href="http://www.sun.com/support/">http://www.sun.com/support/</a>
Training	<a href="http://www.sun.com/training/">http://www.sun.com/training/</a>

---

## Product Updates

For product updates that you can download for the Sun Blade X6440 server module, please visit the following web site:

<http://www.sun.com/download/>

Locate the Hardware Drivers section and click x64 Servers & Workstations. The Sun Blade X6440 server module site contains updates for firmware and drivers, as well as CD-ROM .iso images.

---

## Third-Party Web Sites

Sun is not responsible for the availability of third-party web sites mentioned in this document. Sun does not endorse and is not responsible or liable for any content, advertising, products, or other materials that are available on or through such sites or resources. Sun will not be responsible or liable for any actual or alleged damage or loss caused by or in connection with the use of or reliance on any such content, goods, or services that are available on or through such sites or resources.

---

## Sun Welcomes Your Comments

Sun is interested in improving its documentation and welcomes your comments and suggestions. You can submit your comments by going to:

<http://www.sun.com/hwdocs/feedback/>

Please include the title and part number of your document with your feedback:

*Sun Blade X6440 Server Module Installation Guide*, 820-3961-11



# Installing the Server Hardware

---

This chapter covers the hardware installation of the Sun Blade X6440 server module and service processor connection and verification procedures. This chapter contains the following topics:

- “Before You Begin” on page 2
- “Installation Overview” on page 3
- “Installing the Server Module” on page 4
  - “Installing the Compact Flash Card” on page 4
  - “Inserting the Server Module” on page 5
  - “Placing the Server in Standby Power Mode” on page 7
- “Powering On the Server Module” on page 9
- “Powering Off the Server Module” on page 9
- “Booting the Server Module” on page 9
- “Removing the Compact Flash Card” on page 10

---

# Before You Begin

Before you begin this installation procedure be sure you have the following:

- A functioning (installed and powered) server chassis
- The chassis installation documentation and other supporting documents
- The RJ-45 serial cable that came packed with the Sun Blade X6440 server module
- (Optional) Multi-port dongle cable that came packed with the server module
- A terminal or personal computer running terminal emulation software
- *Sun Blade X6440 Server Module Operating System Installation Guide*
- *Sun Blade X6440 Server Module Windows Operating System Installation Guide*

## Terms Used in This Guide

- The term *server module* refers to the Sun Blade X6440 server module hardware.
- The term *chassis* refers to the modular system hardware.
- The term *compact flash card* refers to the 16GB card that came packed with the server module. The card is used to store a bootable version of the operating system.
- The term *Integrated Lights Out Manager (ILOM)* refers to the built-in system management software that enables the monitoring and managing of installed components in the chassis and server module.
- The term *service processor (SP)* refers to the hardware portion of the ILOM. The SP is capable of functioning independently of the server operating system as well as in power off situations.
- The term *chassis management module (CMM)* refers to the chassis-level ILOM.

---

# Installation Overview

After unpacking your Sun Blade X6440 server module, perform the following tasks to install it into a modular chassis. You must have already installed the chassis before starting the installation.

---

Step	Task	Section
1	Install the CF card into the server module.	<a href="#">“Installing the Compact Flash Card” on page 4</a>
2	Insert the server module into the chassis.	<a href="#">“Inserting the Server Module” on page 5</a>
3	Place the server module in standby power mode.	<a href="#">“Placing the Server in Standby Power Mode” on page 7</a>
4	Connect to the server module through the service processor on the chassis.	<a href="#">“Connecting to the Server Module ILOM” on page 15</a>
5	Configure the ILOM IP address.	<a href="#">“Configuring the ILOM IP Address” on page 25</a>
6	Customize the Sun Blade X6440 server module.	<a href="#">“Customizing the Sun Blade X6440 Server Module’s ILOM” on page 31</a>
6	Configure the preinstalled Solaris™ Operating System or the preinstalled OpenSolaris Operating System.	<a href="#">Chapter 3 or Chapter 4</a>

---

---

# Installing the Server Module

Installation of the Sun Blade X6440 server module consists of the following steps:

1. [“Installing the Compact Flash Card” on page 4](#)
2. [“Inserting the Server Module” on page 5](#)
3. [“Placing the Server in Standby Power Mode” on page 7](#)

## Installing the Compact Flash Card

The compact flash (CF) card slot is located on the rear panel of the server. To install or remove the CF card, you must power off the server and remove it from the chassis. For CF card removal instructions, see [“Removing the Compact Flash Card” on page 10](#).



---

**Caution** – Electrostatic discharge (ESD) can damage system components. The system’s printed circuit boards and hard disk drives contain components that are extremely sensitive to static electricity. Before handling components, wear an ESD wrist strap and attach the grounding cord to bare metal on the chassis or a grounded bare metal surface. Both the front and back of the chassis have grounded locations.

---

### ▼ To Install the CF Card

1. **Set the server module on a flat surface.**
2. **Orient the server so that the CF card slot is positioned as shown in [FIGURE 1-1](#).**  
You can access the CF card from the rear of the server module without removing the server’s cover. If necessary, remove the top cover.



**FIGURE 1-1** Installing the Compact Flash Card

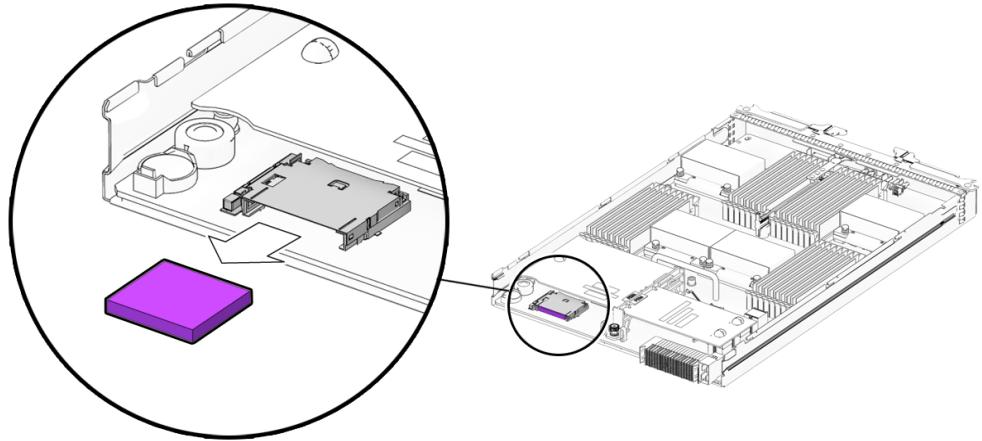

- 3. Insert the CF card into the card slot as shown in [FIGURE 1-1](#).**

Push the card until it seats and locks into place.

## Inserting the Server Module

This section describes the hardware installation of the Sun Blade X6440 server module in a chassis. To perform this procedure you must have already completed the installation of the chassis.

---

**Note** – It is not necessary to power off the chassis to install the Sun Blade X6440 server module.

---

### ▼ To Insert the Server Module

- 1. Locate an available slot in the chassis for the Sun Blade X6440 server module.**
- 2. Make note of the chassis slot or position number.**  
You will need this number in an upcoming step.
- 3. If necessary, remove the filler panel.**  
Pull the filler panel release lever outward to eject the filler panel.



---

**Caution** – Danger of an unexpected chassis shutdown. Do not operate the chassis with empty slots. Always insert a filler panel into any unused slots to reduce the possibility of chassis shutdown.

---

4. Position the server module vertically and orient it so that the ejectors are on the right and extended outwardly (see [FIGURE 1-2](#)).

**FIGURE 1-2** Inserting the Server Module Into the Chassis

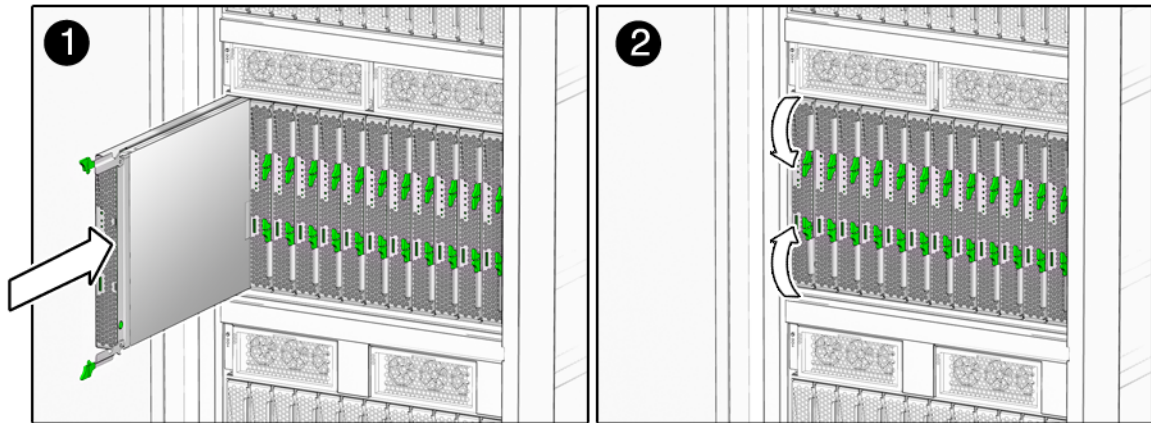

5. Push the server module into the slot until the server module stops.

The module might protrude slightly.

6. Rotate the ejectors levers inward until they are flush with the front of the server module (see [FIGURE 1-2](#)).

The inward movement of the ejector levers seats the server module completely in its internal chassis connector. The front of the server module and the ejector lever arms should now be flush with the chassis. *Do not power on the server module.*

7. Place the server module into standby power mode.

If the chassis was powered on when you inserted the Sun Blade X6440 server module, minimal power is supplied to the server module, and after a few minutes the server module enters standby mode. When the server module is in standby mode, the blue (Ready to Remove) LED is illuminated.

- If the server module is in standby power mode, proceed to [“Connecting to the Server Module ILOM”](#) on page 15.

- If the server module is not in standby power mode, see the next section, [“Placing the Server in Standby Power Mode”](#) on page 7.

## Placing the Server in Standby Power Mode

To perform the initial verification and configuration of the SP, you must first place the server in standby power mode. You can place the server module into standby mode by doing one of the following:

- Inserting the server module into a chassis that is already powered on and *not* powering on the server module
- Inserting the server module into a chassis that is powered off, powering on the chassis, and *not* powering on the server module

In either of these scenarios, once minimal power is supplied to the server module, it will enter standby mode within a couple of minutes. In standby power mode, the blue (Ready to Remove) LED on the front panel is illuminated, indicating that the SP is working. For the location of the blue front panel LED, see [FIGURE 1-3](#).

Proceed to [“Connecting to the Server Module ILOM”](#) on page 15 to perform the initial verification and configuration of the SP.

**FIGURE 1-3** Sun Blade Server Module Front Panel

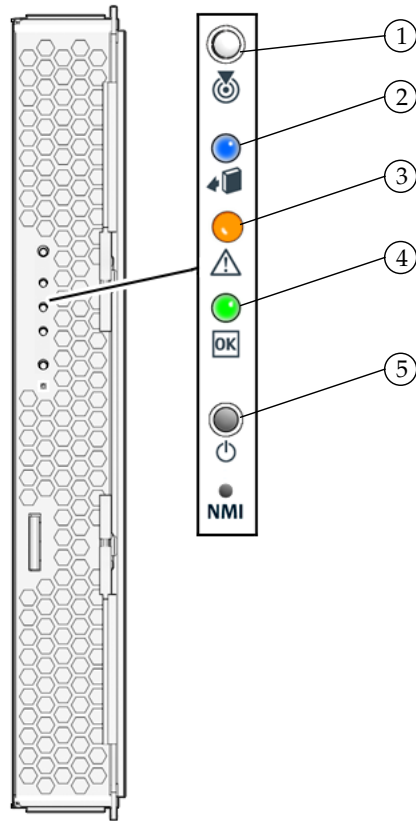

### Legend

- 
- |   |                                   |
|---|-----------------------------------|
| 1 | White LED—Locate                  |
| 2 | Blue LED—Ready to Remove          |
| 3 | Amber LED—Service Action Required |
| 4 | Green LED—Power                   |
| 5 | Power button—standby              |
-

---

## Powering On the Server Module

When you insert the server module into a chassis that is powered on, minimal power is applied to the server module, placing it in standby mode. When the server module is in standby mode, the blue (Ready to Remove) LED is illuminated.

### ▼ To Power On the Server Module

- **Press the Power button on the front panel of the server module.**

The server module powers on and boots. The green front panel lights solidly.

---

## Powering Off the Server Module

Before you remove a powered-on Sun Blade X6440 server module from a chassis, you should take it from a fully operational state and place it into standby mode.

### ▼ To Power Off the Server Module

- **Press and hold the Power button until the blue (Ready to Remove) is illuminated.**

The server is now in standby mode, and you can remove it from the chassis.

---

## Booting the Server Module

Your Sun Blade X6440 server module does not contain hard drives. Therefore, you must configure your server module's system BIOS to boot from an external drive. Your Sun Blade X6440 server module is equipped with a compact flash (CF) card, which you can use to boot a limited number of operating systems and bring the server to an operational state. For more information about booting your Sun Blade

X6440 server module, refer to the *Sun Blade X6440 Server Module Operating System Installation Guide* and the *Sun Blade X6440 Server Module Windows Operating System Installation Guide*.

---

## Removing the Compact Flash Card

The CF card slot is located on the back of the server. To remove the CF card you must first remove the server from the chassis.

---

**Note** – If you remove the CF card, you will not be able to boot the server module.

---

### ▼ To Remove the CF Card



---

**Caution** – Danger of an unexpected chassis shutdown. Do not operate the chassis with empty slots. Always insert a filler panel into any unused slots to reduce the possibility of chassis shutdown.

---

1. **Power off the server** (see [“Powering Off the Server Module”](#) on page 9).

---

**Note** – It is not necessary to power off the chassis to remove the Sun Blade X6440 server module.

---

2. **Pull the ejector levers upward, and rotate the levers until they are horizontal.**

The action of rotating the levers pulls the server module out of its internal connector, allowing you to easily remove it.

3. **Remove the server module by sliding it out from its slot.**

4. **Set the server module on a flat surface.**

5. **Insert a filler panel into the vacant slot.**

6. **Orient the server so that the CF card slot is positioned as shown in [FIGURE 1-4](#).**

**FIGURE 1-4** Removing the Compact Flash Card

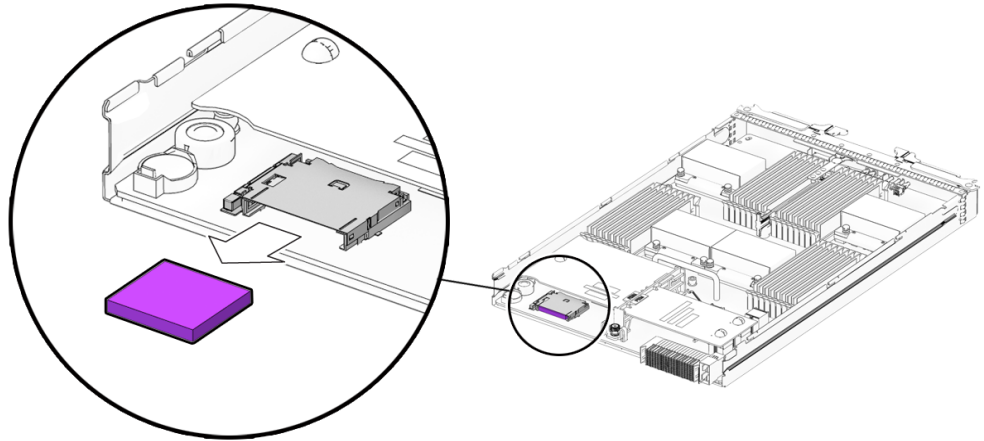

7. Push in on the edge of the CF card.
8. Push the CF card ejector button to release the card from its holder.  
This action causes the spring-loaded card to eject.
9. Remove the card.





## Setting Up the Server Software

---

This chapter describes how to configure and access the Sun™ Integrated Lights Out Manager software, and how to set up the platform operating system and driver software.

This chapter contains these topics:

- [“Integrated Lights Out Manager” on page 13](#)
  - [“What Is a Service Processor?” on page 14](#)
  - [“About the Preconfigured Administrator Account” on page 14](#)
  - [“ILOM Connection Overview” on page 15](#)
  - [“Connecting to the Server Module ILOM” on page 15](#)
  - [“Configuring the ILOM IP Address” on page 25](#)
  - [“Customizing the Sun Blade X6440 Server Module’s ILOM” on page 31](#)
- [“Setting Up Platform Operating System and Driver Software” on page 31](#)

---

## Integrated Lights Out Manager

Sun Integrated Lights Out Manager (ILOM) is built-in system management software that enables you to control your system. Using ILOM, you can monitor and manage the components installed in your chassis and server modules, configure network information, view and edit hardware configurations, monitor vital system information, and manage user accounts.

You can access ILOM through several interfaces, such as the web browser interface, command-line interface (CLI), SNMP interface, as well as the IPMI interface.

---

**Note** – This chapter describes how to access ILOM through the command-line interface and web browser. For other methods, see the *Sun Integrated Lights Out Manager 2.0 User's Guide*.

---

## What Is a Service Processor?

A service processor (SP) is a component, located on the server module's motherboard, that operates independently of the other hardware in the system. The SP has its own IP address and MAC address and is capable of operating regardless of the state of the other system hardware. In a server module, the service processor can operate whether the server module is fully operational, powered down, or somewhere in between.

The chassis management module (CMM) and every server module in the chassis has its own service processor.

Note the following terms used in this book:

- The term *chassis management module* (CMM) refers to the hardware module on the chassis.
- The *CMM ILOM* refers to the ILOM software on the CMM.
- The *server module SP* (service processor) refers to the server module's SP hardware.
- The *server module ILOM* refers to the ILOM software on the server module SP.

Note that other server modules might have different service processors.

## About the Preconfigured Administrator Account

The server module ILOM is shipped with a preconfigured Administrator account:

**User name:** `root`

**Password:** `changeme`

The preconfigured Administrator account, known as `root`, cannot be deleted or changed, other than changing its password. This account offers built-in administrative privileges (read and write access) to all service processor features and commands.

---

**Note** – The CMM ILOM is shipped with an identical preconfigured Administrator account, with user name `root` and the default password set to `changeme`.

---

## ILOM Connection Overview

FIGURE 2-1 shows the connections to the server module ILOM.

FIGURE 2-1 ILOM Connection Options

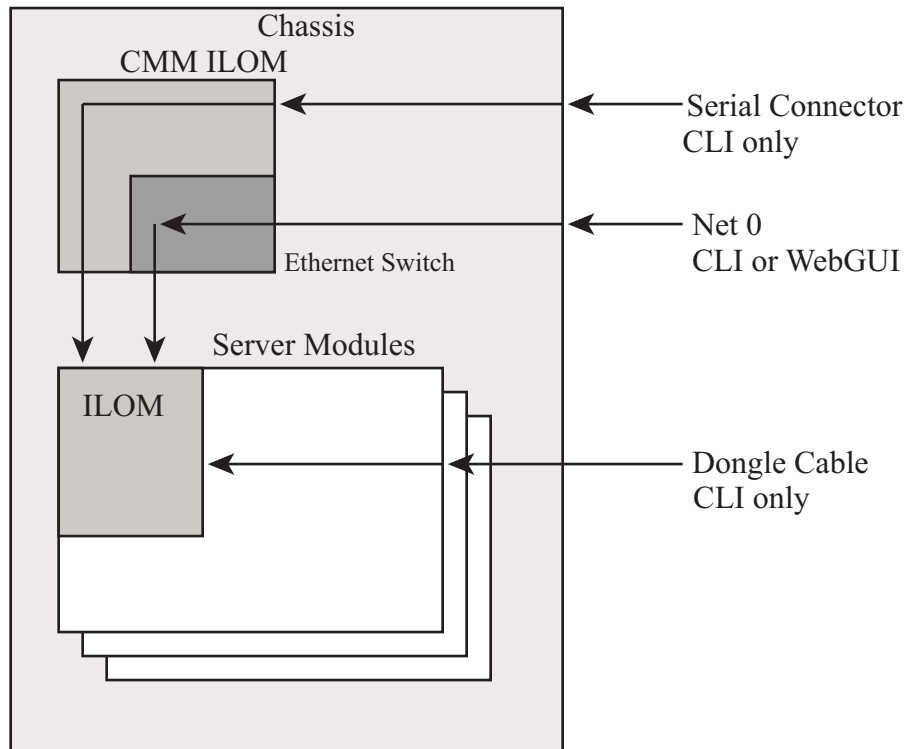

## Connecting to the Server Module ILOM

Before you continue installing the server module, you must ensure that you can connect to ILOM.

You can connect to the server module ILOM using one of several methods listed next and described in the corresponding sections.

---

**Note** – Option 1 and option 2 enable you to connect to ILOM without knowing ILOM’s IP address. These options provide access to ILOM’s command-line interface (CLI) only. Option 3 requires you to know ILOM’s IP address, but supports CLI and web GUI access. Most users configure ILOM’s IP address, then connect to it using Option 3.

Instructions for configuring ILOM’s IP address are in [“Configuring the ILOM IP Address” on page 25](#).

---

- **Option 1.** Use the serial connector on the chassis to connect to the CMM ILOM. Then use the CMM ILOM to navigate to the server module ILOM. See [“Option 1: Connecting to ILOM Through the Chassis Serial Connector” on page 16](#).
- **Option 2.** Use a dongle cable to establish a serial connection directly to the server module ILOM. See [“Option 2: Connecting to ILOM Through a Dongle Cable” on page 20](#).
- **Option 3.** Connect through the Ethernet. This connection supports both CLI and web GUI access. See [“Option 3: Connecting to ILOM Through the Ethernet Port” on page 21](#).

The following sections describe each of these methods.

## Option 1: Connecting to ILOM Through the Chassis Serial Connector

The chassis serial connector connects to the CMM ILOM, which provides a command to connect to the server module ILOM.

### ▼ To Connect to ILOM Through the Chassis Serial Connector

You can access the CMM ILOM at any time by connecting a terminal or a PC running terminal emulation software to the RJ-45 serial port on the chassis. The CMM ILOM’s command-line interface (CLI) enables you to connect to the server module ILOM.

Before completing this connection, the server module must be installed in the chassis.

1. **Verify that your terminal, laptop, or terminal server is operational.**

2. **Configure the terminal device or the terminal emulation software to use the following settings:**
  - 8N1: eight data bits, no parity, one stop bit
  - 9600 baud (default, can be set to any standard rate up to 57600)
  - Disable hardware flow control (CTS/RTS)
3. **Connect a serial cable from the serial port on the chassis to a terminal device.**  
Refer to the chassis documentation for the location of the serial port.

---

**Note** – The serial port requires the following pin assignments. Note that these are the same as the serial cable connector for the Sun Advanced Lights Out Manager (ALOM) or Remote System Control (RSC). See [TABLE 2-1](#).

---

**TABLE 2-1** Serial Management Port Pinouts

Pin	Signal Description
1	Request To Send (RTS)
2	Data Terminal Ready (DTR)
3	Transmit Data (TXD)
4	Ground
5	Ground
6	Receive Data (RXD)
7	Data Carrier Detect (DCD)
8	Clear To Send (CTS)

**4. Press Enter on the terminal device.**

This establishes the connection between the terminal device and the CMM ILOM.

---

**Note** – If you connect a terminal or emulator to the serial port before it has been powered up or during its power up sequence, you will see bootup messages.

---

When the system has booted, the CMM ILOM displays its login prompt:

```
SUNCMMnnnnnnnnnnnnnnnn login:
```

The first string in the prompt is the default host name. It consists of the prefix SUNCMM and the CMM ILOM's MAC address. The MAC address for each service processor is unique.

5. Log in to the CLI:

a. Type the default user name, **root**.

b. Type the default password, **changeme**.

Once you have successfully logged in, the CMM ILOM displays its default command prompt:

->

You are now connected to the CMM ILOM CLI.

6. Navigate to the server module ILOM by typing this command:

-> **cd /CH/BLn/SP/cli**

Where *n* is 0 through 9 for server modules 0 through 9 respectively.

7. Type the command **start**.

A prompt appears.

8. Type **y** to continue or **n** to cancel.

If you typed **y**, the server module ILOM prompts for its password.

---

**Note** – The CMM ILOM logs on to the server module ILOM using the user name in the *user* target under */CH/BLn/SP/cli* (where *n* is the server module number).

---

9. When prompted, type the password.

The default password is **changeme**.

The server module ILOM prompt appears. You are now connected to the server module ILOM.

10. Type **exit** when you are done.

The server module ILOM exits and the CMM CLI prompt appears.

The following display shows an example of the login screen.

```
-> cd /CH/BL2/SP/cli
/CH/BL2/SP/cli

-> start
Are you sure you want to start /CH/BL2/SP/cli (y/n)? y
Password: Type the password to the server module ILOM.

Sun(TM) Integrated Lights Out Manager

Version 2.0.3.9

Copyright 2008 Sun Microsystems, Inc. All rights reserved.
Use is subject to license terms.

Warning: password is set to factory default.

-> exit Type this command to exit the server module ILOM and return to the
CMM ILOM.
Connection to 10.6.153.33 closed.
```

## Option 2: Connecting to ILOM Through a Dongle Cable

You can use the dongle cable to connect a terminal directly to the server module ILOM. [FIGURE 2-2](#) shows a dongle cable connected to a server module.



**Caution** – The dongle cable should be used only for configuration and service purposes. It should be disconnected from the server module when the configuration or servicing operation is completed.

If you have a dongle cable connected to a server module, it must be removed before closing the door of a rack cabinet. The dongle cable may be damaged if it is not removed before the cabinet door is closed.

**FIGURE 2-2** Dongle Cable

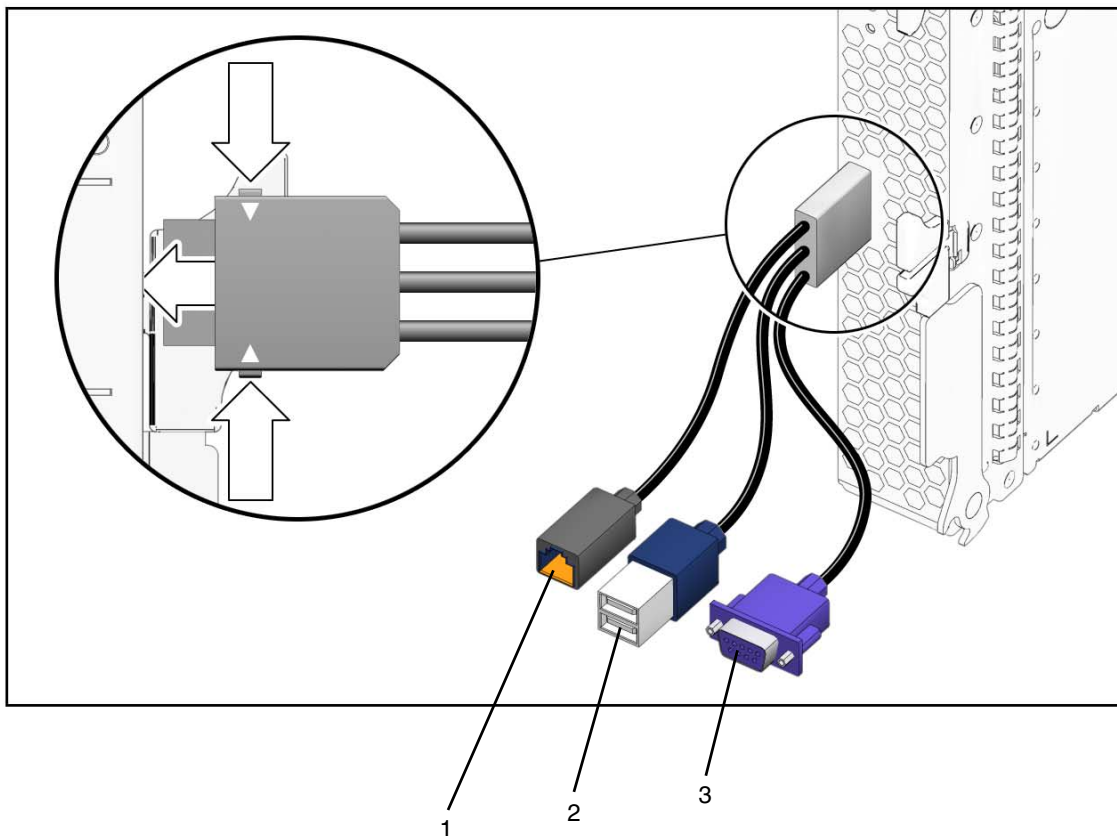



## Legend

---

	Connector	Status
1	Serial port connector	Used
2	Dual USB connectors	Used
3	VGA video connector	Used

---

## ▼ To Connect to ILOM Using a Dongle Cable

1. **Connect a dongle cable to the server module.**
2. **Connect a terminal or terminal emulator to the RJ-45 serial port connector (labeled as 1 in the figure) on the dongle cable.**

The ILOM login prompt appears.

3. **Type the user name and password when prompted.**

The default user name is **root** and the default password is **changeme**.

The server module ILOM prompt appears.

4. **When you are done, exit ILOM by typing:**

-> **exit**

## Option 3: Connecting to ILOM Through the Ethernet Port

The chassis Ethernet ports provide the most robust method of connecting to ILOM. This connection supports both the CLI and the web GUI.

You can connect to ILOM through either the RJ-45 NET MGT 0 Ethernet port or the corresponding network express module (NEM) port.

Before you can use the Ethernet connection, you must know ILOM's IP address.

---

**Note** – To configure the ILOM IP address, see [“Configuring the ILOM IP Address” on page 25](#).

---

# Logging In and Out of ILOM

You can use either the ILOM command-line interface (CLI) or web GUI to access ILOM.

## ▼ To Log In and Out of the ILOM CLI

ILOM supports Secure Shell (SSH) access to the CLI over the Ethernet.

### 1. Start an SSH client.

### 2. To log in to ILOM CLI, type:

```
$ ssh root@ipaddress
```

Where *ipaddress* is the IP address of the server SP.

### 3. Type your password when prompted.

The default user name is **root**, and the default password is **changeme**.

For example:

```
$ ssh root@192.168.25.25
root@192.168.25.25's password:
Sun Integrated Lights Out Manager
Version 2.0.3.9
Copyright 2008 Sun Microsystems, Inc. All rights reserved.
Warning: password is set to factory default.
->
```

### 4. To log out of ILOM, type **exit**.

## ▼ To Log In and Out of the ILOM Web GUI

### 1. To log in to the ILOM web GUI, type the IP address of the ILOM service processor into your web browser.

The ILOM login screen appears.

**FIGURE 2-3** ILOM Login Screen

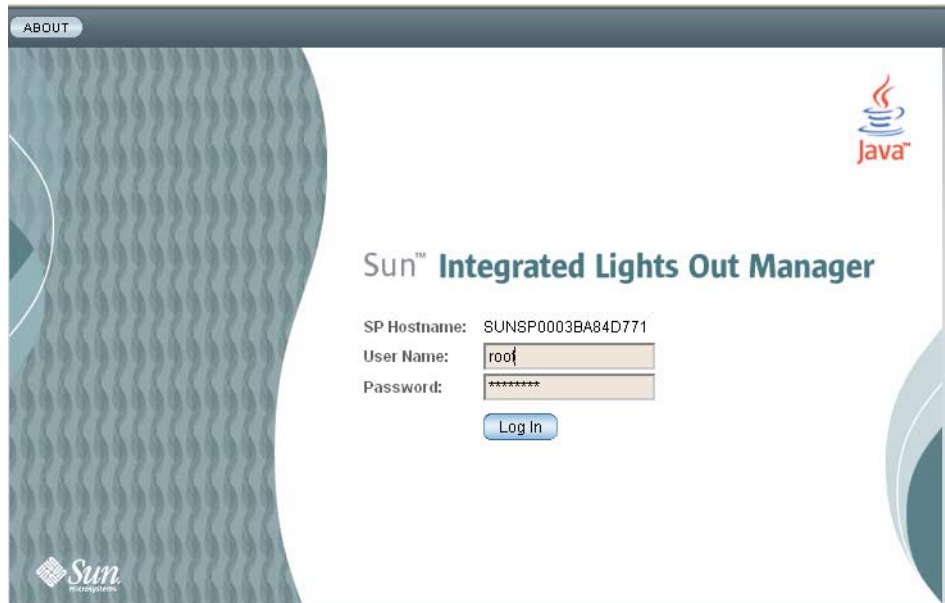

**2. Type your user name and password.**

When you first try to access the web GUI, it prompts you to type the default user name and password. The default user name and password are:

- Default user name – root
- Default password – changeme

The default user name and password are in lowercase characters.

**3. Click Log In.**

The web GUI appears.

**4. To log out of the web GUI, click the Log Out button at the top right of the web GUI.**

The ILOM log out screen appears.



---

**Caution** – Do not use the Log Out button in your web browser to log out from the ILOM web GUI.

---

**FIGURE 2-4** ILOM Log Out Screen

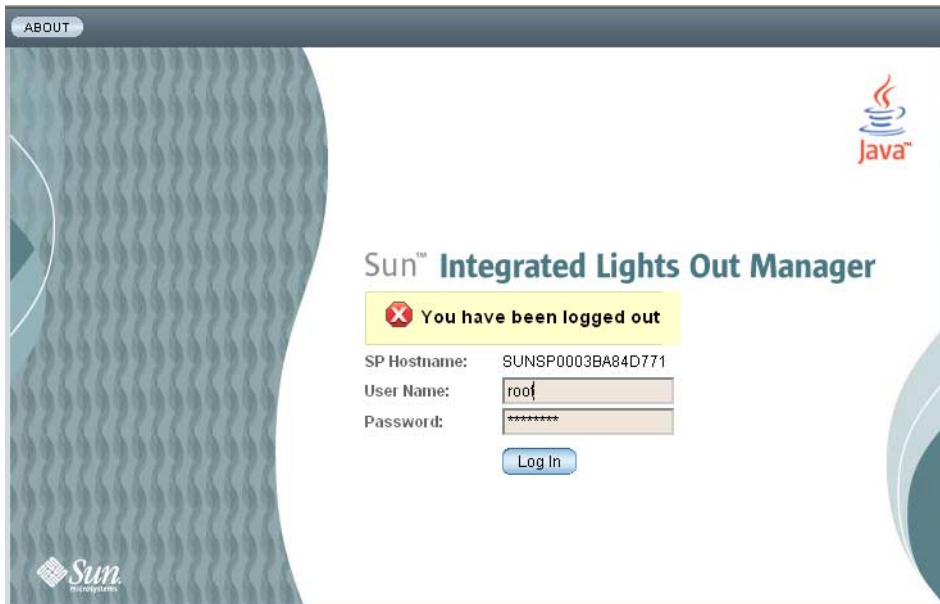

# Configuring the ILOM IP Address

This section describes how to view and set the ILOM IP address. It includes the following sections:

- [“To View the ILOM IP Address” on page 25](#)
- [“To Configure the ILOM IP Address Using BIOS Setup Utility” on page 25](#)
- [“To Configure the ILOM IP Address Using DHCP” on page 27](#)
- [“To Configure the ILOM IP Address Using the CLI” on page 28](#)

## ▼ To View the ILOM IP Address

1. **Log in to the ILOM CLI using any of the methods described in [“Connecting to the Server Module ILOM” on page 15](#).**

To use the Ethernet SSH connection, you must already know the IP address.

2. **Type these commands from the *root* directory.**

- a. **To see all the IP address-related information, type:**

```
-> show /SP/network
```

- b. **To see only the IP address, type:**

```
-> show /SP/network/ipaddress
```

## ▼ To Configure the ILOM IP Address Using BIOS Setup Utility

The BIOS Setup Utility enables you to set the ILOM IP address. You can configure the IP address manually (static) or use DHCP to configure it.

1. **Verify the following:**

- Your DHCP server is configured to accept new media access control (MAC) addresses.
- Your DHCP server is connected to either the corresponding NEM port or the RJ-45 NET MGT Ethernet port.

2. **Start the BIOS Setup Utility.**

- a. **Boot the system.**

- b. **Watch the boot messages. You will see a line that says you can press F2 to enter BIOS setup.**

c. After you see the message, press F2.

After some messages and screen changes, the BIOS Setup Utility appears.

**3. Select the Advanced tab.**

The Advanced page appears.

**4. Highlight IPMI 2.0 Configuration in the list, then select Enter.**

The IPMI 2.0 Configuration page appears.

**5. Highlight LAN Configuration, then select Enter.**

The LAN Configuration page appears.

**6. On the LAN Configuration page, under IP Assignment, select DHCP or Static.**

If you selected Static, fill in the IP address, subnet mask, and default gateway at the bottom of the page.

**7. Select Commit to save your changes.**

The BIOS utility automatically updates the address fields.

- If you selected Static, you are done.
- If you selected DHCP, the DHCP server assigns an IP address to the server module ILOM. Continue to [Step 8](#).



---

**Caution** – You must select Commit to save the changes on this page. Using F10 will not save your changes.

---

**8. To find the IP address that DHCP assigned to the server module ILOM, either:**

- Log in to ILOM CLI using option 1 or option 2 (see [“Connecting to the Server Module ILOM” on page 15](#)) and enter this command:  
**show /SP/network**
- Look in the DHCP log file.

---

**Note** – Different DHCP server applications running on different operating systems store these log files in different locations. Consult your DHCP system administrator to locate the correct path to the log file.

---

Typically, DHCP log file entries are individual lines with the following comma-separated fields:

*ID, Date, Time, Description, IP Address, Host Name, MAC Address*

Locate the MAC address of your ILOM in the MAC Address (seventh) field of the correct DHCP file entry, and record the corresponding value of the IP Address (fifth) field. This is the IP address that you must use to access the web GUI and the ILOM Remote Console application.

## ▼ To Configure the ILOM IP Address Using DHCP

This procedure uses DHCP to assign ILOM an IP address.

1. **Verify that your DHCP server is configured to accept new media access control (MAC) addresses.**

2. **Obtain the server module ILOM MAC address from one of the following locations:**

MAC addresses are 12-digit hexadecimal strings in the format `xx:xx:xx:xx:xx:xx` where x represents a single hexadecimal letter (0–9, A–F, a–f). Write down the address for future reference.

- The server module has a serial port to which you can attach a terminal device. If you log into ILOM and type the command `show /SP/network`, ILOM displays the current MAC address. See [“Option 2: Connecting to ILOM Through a Dongle Cable” on page 20](#).
- The CMM has a serial port to which you can attach a terminal device. If you log into the CMM ILOM and type the command `show /CH/BLn/SP/network`, the CMM ILOM displays the current MAC address. See [“Option 3: Connecting to ILOM Through the Ethernet Port” on page 21](#).
- The Customer Information Sheet shipped with your server module lists the MAC address.
- You can get the MAC address from the system BIOS Setup screen. Choose Advanced - IPMI 2.0 Configuration - Set LAN Configuration - MAC address.

3. **Connect an Ethernet cable to the network express module (NEM) port corresponding to the server module.**

Refer to your chassis documentation for the location of the NEM port.

---

**Note** – DHCP requires a connection to the server module through the NEM before DHCP can assign an IP address to the server module ILOM.

DHCP cannot automatically assign an address to the server module ILOM if it is only connected to the RJ-45 NET MGT Ethernet port.

---

4. **Reset the server module ILOM.**

- a. **Log in to the server module ILOM.** See [“Option 1: Connecting to ILOM Through the Chassis Serial Connector” on page 16](#) or [“Option 3: Connecting to ILOM Through the Ethernet Port” on page 21](#).

**b. Type the reset command:**

```
-> reset /SP
```

DHCP automatically assigns ILOM an IP address when the server module restarts.

**5. Find the IP address that DHCP assigned to the server module ILOM.**

See [Step 8](#) in [“To Configure the ILOM IP Address Using BIOS Setup Utility”](#) on page 25.

## ▼ To Configure the ILOM IP Address Using the CLI

This procedure describes how to manually configure the ILOM IP address using the CLI.

**1. Connect to the server module ILOM using one of the following methods:**

- Connect to the server module ILOM using the chassis serial connector as described in [“Option 1: Connecting to ILOM Through the Chassis Serial Connector”](#) on page 16.
- Connect to the server module ILOM using a dongle cable as described in [“Option 2: Connecting to ILOM Through a Dongle Cable”](#) on page 20.
- Connect to the server module ILOM using SSH as described in [“Option 3: Connecting to ILOM Through the Ethernet Port”](#) on page 21.

**2. To see the IP address, type `show /SP/network/ipaddress`.**

The last string, `/ipaddress`, is optional.

```
-> show /SP/network/ipaddress

/SP/network
  Targets:

  Properties:
    ipaddress = 10.6.153.148

  Commands:
    show

->
```

**3. To navigate to `/SP/network`, type:**

```
-> cd /SP/network
```



#### 4. Do one of the following:

- To configure a static Ethernet configuration, type the following commands:

```
-> set pendingipdiscovery=static  
-> set pendingipaddress=xxx.xxx.xx.xx  
-> set pendingipnetmask=yyy.yyy.yyy.y  
-> set pendingipgateway=zzz.zzz.zz.zzz  
-> set commitpending=true
```

where *xxx.xxx.xx.xx*, *yyy.yyy.yyy.y* and *zzz.zzz.zz.zzz* are the IP address, netmask, and gateway for your ILOM and network configuration. To determine these addresses, see your system administrator.

- To configure a dynamic Ethernet configuration, type the following commands:

```
-> set pendingipdiscovery=dhcp  
-> set commitpending=true
```

#### 5. To log out of ILOM, type:

```
-> exit
```

If you connected to the server module ILOM through the CMM ILOM, you will be returned to the CMM ILOM.

If you connected to ILOM using SSH, you will be disconnected automatically, because you logged in under a different IP address. If it is taking a long time to be disconnected, you can force a disconnect by typing `~.` in the SSH window.

The following display shows a typical session where the user looks at static settings, configures them to be dynamic, then looks at the new settings.

```

-> cd /SP/network

-> show

/SP/network
Targets:

Properties:
  commitpending = (Cannot show property)
  ipaddress = 10.6.42.42
  ipdiscovery = static
  ipgateway = 10.6.42.1
  ipnetmask = 255.255.255.0
  macaddress = 00:14:4F:3A:26:74
  pendingipaddress = 10.6.42.42
  pendingipdiscovery = static
  pendingipgateway = 10.6.42.1
  pendingipnetmask = 255.255.255.0

Commands:
  cd
  set
  show

-> set pendingipdiscovery=dhcp
Set 'pendingipdiscovery' to 'dhcp'

-> set commitpending=true
Set 'commitpending' to 'true'
if you logged in using SSH, you will be disconnected here.

-> show

/SP/network
Targets:

Properties:
  commitpending = (Cannot show property)
  ipaddress = 10.6.42.191
  ipdiscovery = dhcp
  ipgateway = 10.6.42.1
  ipnetmask = 255.255.255.0
  macaddress = 00:14:4F:3A:26:74
  pendingipaddress = 10.6.42.191
  pendingipdiscovery = dhcp
  pendingipgateway = 10.6.42.1
  pendingipnetmask = 255.255.255.0

Commands:
  cd
  set
  show

```

# Customizing the Sun Blade X6440 Server Module's ILOM

To customize your Sun Blade X6440 server module's ILOM, including managing users, defining event filters, setting up email notification, and using the web-based interface, refer to the following Sun documentation:

- *Sun Integrated Lights Out Manager (ILOM) 2.0 User's Guide*
- *Sun Integrated Lights Out Manager (ILOM) Supplement for Sun Blade X6440 Server Module*

---

## Setting Up Platform Operating System and Driver Software

After configuring the server module ILOM network settings, you can configure either the preinstalled Solaris 10 Operating System or the preinstalled OpenSolaris Operating System. You can also install a supported Linux or Windows operating system and drivers.

- If you want to use the preinstalled Solaris 10 operating system, refer to [“Configuring the Preinstalled Solaris 10 Operating System”](#) on page 33.
- If you want to use the preinstalled OpenSolaris Operating System, refer to [“Configuring the Preinstalled OpenSolaris Operating System”](#) on page 43.
- For details about installing a supported Linux or Solaris OS and the required drivers, refer to *Sun Blade X6440 Server Module Operating System Installation Guide* (820-3962).
- For details about installing a supported Windows OS and the required drivers, refer to *Sun Blade X6440 Server Module Windows Operating System Installation Guide* (820-3963).
- For additional OS considerations specific to this server, also refer to the *Sun Blade X6440 Server Module Product Notes* (820-3965).



# Configuring the Preinstalled Solaris 10 Operating System

---

This chapter explains the steps for configuring the Solaris™ 10 Operating System (OS) that has been preinstalled on your server, if ordered. The preinstalled version is Solaris 10 5/08 or later.

---

**Note** – If you connect a monitor to the Sun Blade X6440 server module, you will *not* see the output of the preinstalled Solaris 10 image on the monitor when you power on the server. You will see the BIOS power-on self-test (POST) and other boot information output. This is because the server ships with its console redirected to the *serial* port. You can choose an option to send the output to VGA (video port). For more information, see [“\(Optional\) To Redirect the Console Output to the Video Port” on page 40](#).

---

This chapter includes the following topics:

- [“Before You Begin” on page 34](#)
- [“Configuring the Preinstalled Solaris 10 Operating System” on page 38](#)
- [“Solaris 10 Operating System User Information” on page 40](#)
- [“Using the Solaris Installation Program” on page 41](#)
- [“Reinstalling the Solaris Operating System” on page 42](#)
- [“Downloading the Solaris Operating System” on page 42](#)

---

## Before You Begin

Before you begin configuring the preinstalled Solaris 10 OS, do the following:

- Perform initial configuration of the server's ILOM and determine the server's network settings, as described in [Chapter 2](#).
- Gather the information that you will need for the configuration, as listed in ["Installation Worksheet" on page 34](#).

---

**Tip** – To find the server module, PCI ExpressModule, and SP MAC addresses, see the Customer Information Sheet included with the system box, or see the server, PCI EM, and SP MAC addresses printed on their respective labels.

---

## Installation Worksheet

Use the worksheet in [TABLE 3-1](#) to gather the information that you need to configure the preinstalled Solaris 10 OS. You need to collect only the information that applies to your application of the system.

**TABLE 3-1** Worksheet for Solaris 10 Configuration

Information for Installation		Description or Example	Your Answers: Defaults (*)
Language		Select from the list of available languages for the Solaris 10 software.	English*
Locale		Select your geographic region from the list of available locales.	
Terminal		Select the type of terminal that you are using from the list of available terminal types.	
Network connection		Is the system connected to a network?	<ul style="list-style-type: none"> <li>• Networked</li> <li>• Non-networked*</li> </ul>
DHCP		Can the system use Dynamic Host Configuration Protocol (DHCP) to configure its network interfaces?	<ul style="list-style-type: none"> <li>• Yes</li> <li>• No*</li> </ul>
If you are not using DHCP, note the network address:	IP address	If you are not using DHCP, supply the IP address for the system. Example: 129.200.9.1	
	Subnet	If you are not using DHCP, is the system part of a subnet? If yes, what is the netmask of the subnet? Example: 255.255.0.0	255.255.0.0*
	IPv6	Do you want to enable IPv6 on this machine?	<ul style="list-style-type: none"> <li>• Yes</li> <li>• No*</li> </ul>
Host name		A host name that you choose for the system.	
Kerberos		Do you want to configure Kerberos security on this machine? If yes, gather the following information: <div style="text-align: right; margin-right: 50px;">                     Default realm:                      Administration server:                      First KDC:                      (Optional) Additional KDCs:                 </div>	<ul style="list-style-type: none"> <li>• Yes</li> <li>• No*</li> </ul>

**TABLE 3-1** Worksheet for Solaris 10 Configuration (*Continued*)

Information for Installation		Description or Example	Your Answers: Defaults (*)
Name service	Name service	If applicable, which name service should this system use?	<ul style="list-style-type: none"> <li>• NIS+</li> <li>• NIS</li> <li>• DNS</li> <li>• LDAP</li> <li>• None*</li> </ul>
	Domain name	Provide the name of the domain in which the system resides.	
	NIS+ and NIS	Do you want to specify a name server, or let the installation program find one?	<ul style="list-style-type: none"> <li>• Specify One</li> <li>• Find One*</li> </ul>
	DNS	<p>Provide IP addresses for the DNS server. You must enter at least one IP address, but you can enter up to three addresses.</p> <p>You can also enter a list of domains to search when a DNS query is made.</p> <p style="text-align: right;">Search domain: Search domain: Search domain:</p>	
	LDAP	<p>Provide the following information about your LDAP profile:</p> <p style="text-align: right;">Profile name: Profile server:</p> <p>If you specify a proxy credential level in your LDAP profile, gather the following information:</p> <p style="text-align: right;">Proxy-bind distinguished name: Proxy-bind password:</p>	



**TABLE 3-1** Worksheet for Solaris 10 Configuration (*Continued*)

<b>Information for Installation</b>	<b>Description or Example</b>	<b>Your Answers: Defaults (*)</b>
Default route	<p>Do you want to specify a default route IP address, or let the Solaris installation program find one?</p> <p>The default route provides a bridge that forwards traffic between two physical networks. An IP address is a unique number that identifies each host on a network.</p> <p>You have the following choices:</p> <ul style="list-style-type: none"><li>• You can specify the IP address. An <code>/etc/defaultrouter</code> file is created with the specified IP address. When the system is rebooted, the specified IP address becomes the default route.</li><li>• You can let the Solaris installation program detect an IP address. However, the system must be on a subnet that has a router that advertises itself by using the Internet Control Message Protocol (ICMP) for router discovery. If you are using the command-line interface, the software detects an IP address when the system is booted.</li><li>• You can select None if you do not have a router or do not want the software to detect an IP address at this time. The software automatically tries to detect an IP address on reboot.</li></ul>	<ul style="list-style-type: none"><li>• Specify One</li><li>• Detect One</li><li>• None*</li></ul>
Time zone	How do you want to specify your default time zone?	<ul style="list-style-type: none"><li>• Geographic region*</li><li>• Offset from GM</li><li>• Time zone file</li></ul>
Root password	Choose a root password for the system.	

---

# Configuring the Preinstalled Solaris 10 Operating System

---

**Note** – Before you perform this procedure, you need to set up the service processor. If you have not done so, see [Chapter 2](#).

---

Use the information that you gathered in “[Installation Worksheet](#)” on page 34 as you perform the configuration.

After configuring the server module ILOM, you can configure the preinstalled Solaris 10 Operating System (OS) by using the service processor to connect to the system console.

## ▼ To Configure the Preinstalled Solaris 10 OS

You can connect to the service processor using a serial terminal, or the Ethernet, as described in “[Connecting to the Server Module ILOM](#)” on page 15.

If you connect to the service processor using a serial terminal, you can use one of the following options:

- To capture the serial port output, on a client running the Solaris OS, type:  
`$tip -9600 /dev/ttya`
- On a client running the Windows OS, start a program such as Hyperterminal.
- On a client running the Linux OS, start a program such as Minicom, a text-based serial communication program that is included in the Linux distributions. For more information, see the man pages included in the Linux distribution.

1. **Connect and log in to the service processor using one of the methods described in “[Connecting to the Server Module ILOM](#)” on page 15.**

The server module ILOM CLI prompt appears.

->

2. Verify that the communication properties of the service processor are set to the defaults. For example:

```
-> show /SP/serial/host
/SP/serial/host
  Targets:

  Properties:
    commitpending = (Cannot show property)
    pendingspeed = 9600
    speed = 9600

  Commands:
    cd
    show
```

3. If the speed is anything other than 9600, change it by entering the command:

```
-> set /SP/serial/host pendingspeed=9600 commitpending=true
```

4. Start the serial console mode by entering the following command:

```
-> start /SP/console
```

Only accounts with Administrator privileges are enabled to configure the SP.

5. When the prompt appears, type **y**:

```
Are you sure you want to start /SP/console (y/n)? y
```



---

**Caution** – Electrocutation or equipment damage possible if an electrically conductive object is used to activate the recessed Power button.

---

6. Turn on the server module by using a pointed non-conducting object or stylus to press the recessed Power button on the front panel.

POST messages appear on your screen as the OS boots.

7. Follow the Solaris 10 preinstallation on-screen prompts.

8. Use the information gathered in [“Installation Worksheet” on page 34](#) to help you enter the system and network information as you are prompted.

The screens that are displayed vary, depending on the method that you selected for assigning network information to the server (DHCP or static IP address).

After you have entered the system configuration information, the server completes the boot process and displays the Solaris login prompt.

## ▼ (Optional) To Redirect the Console Output to the Video Port

The server module's console is automatically directed to the serial port. GRUB, the open source boot loader, is the default boot loader in the Solaris OS for x86-based or x64-based systems. The boot loader is the first software program that runs after you power on a system.

1. Use a cable to connect the serial port of the host server (either through the chassis SER MGT port or through a dongle cable's serial port) to the video port of the client system.
2. From the GRUB menu, you have the option of displaying the installation process to a VGA connection (video port) as shown here:

```
*****
* Solaris 10 5/08 s10x_u5wos_10 X86 - Serial Port (ttya) *
* Solaris 10 5/08 s10x_u5wos_10 X86 - Graphics Adapter *
* Solaris failsafe *
* *
* *
* *
* *
* *
*****

To display output to the video port, choose the following option:
Solaris 10 5/08 s10x_u5wos_10 X86 - Graphics Adapter
```

---

## Solaris 10 Operating System User Information

This section provides pointers to information about the Solaris 10 Operating System.

# Solaris 10 User Documentation

You can access the various collections of the Solaris 10 OS user documentation at:

<http://docs.sun.com/app/docs/prod/solaris.10>

## Solaris 10 OS Training

Sun provides flexible training options that accommodate your personal schedule and learning style. The training options include instructor-led, web-based online, CD-ROM, and Live Virtual Class. For Solaris 10 Training and Certification options at a glance, go to:

<http://www.sun.com/training/catalog/solaris10.html>

---

## Using the Solaris Installation Program

The documentation listed in this section provides instructions for using the Solaris installation program and is available at the following web site:

<http://docs.sun.com/>

Follow the instructions for *x86-based* systems, not *SPARC-based* systems. For more information, see the Solaris 10 Release and Installation Collection for the version of the Solaris 10 Operating System that you have installed. This documentation is available at:

<http://docs.sun.com/app/docs/prod/solaris.10>

After you configure the preinstalled Solaris OS, the Solaris installation program reboots the system and prompts you to log in. The system displays the message of the day, indicating the preloaded software that comes with your system:

- Sun Java™ Enterprise System (Java ES)
- Sun Studio™ 11

## Sun Java Enterprise System

Sun Java Enterprise System (Java ES) is a set of software components that provide services needed to support enterprise-strength applications distributed across a network or Internet environment.

## Sun Studio 11

Sun Studio 11 includes high-performance, optimizing C, C++, and Fortran compilers for the Solaris OS on SPARC and x86/x64 platforms. It also includes command-line tools and a NetBeans™-based integrated development environment (IDE) for analyzing application performance and debugging mixed source language applications. The tools offer multi-platform support, compatible with gcc, Visual C++, C99, OpenMP, and Fortran 2003.

---

## Reinstalling the Solaris Operating System

If you want to reinstall the Solaris OS or to install a different version of the Solaris OS, you can do so in one of several ways, including by using DVD and network (using the Jumpstart Enterprise Toolkit [JET]).

For step-by-step procedures, see the *Solaris 10 Installation Guide: Basic Installations* (820-0176). See also the *Sun Blade X6440 Server Module Operating System Installation Guide* (820-3962).

---

## Downloading the Solaris Operating System

If you need to reinstall software, you can download the software from the following sites:

- To download the Solaris 10 Operating System, go to:

<http://www.sun.com/software/solaris/get.jsp>

- To download patches, go to:

<http://sunsolve.sun.com/pub-cgi/show.pl?target=home>

# Configuring the Preinstalled OpenSolaris Operating System

---

This chapter explains the steps for configuring the OpenSolaris Operating System (OpenSolaris OS) that has been preinstalled on your server, if ordered. The preinstalled version is OpenSolaris 2009.06 or later.

---

**Note** – If you connect a monitor to the Sun Blade X6440 server module, you will *not* see the output of the preinstalled OpenSolaris image on the monitor when you power on the server. You will see the BIOS power-on self-test (POST) and other boot information output. This is because the server ships with its console redirected to the *serial* port. You can choose an option to send the output to VGA (video port). For more information, see [“\(Optional\) To Redirect the Console Output to the Video Port” on page 50](#).

---

This chapter includes the following topics:

- [“Before You Begin” on page 44](#)
- [“Configuring the Preinstalled OpenSolaris Operating System” on page 48](#)
- [“Getting Started With the OpenSolaris Operating System” on page 51](#)
- [“Using the OpenSolaris Installation Program” on page 52](#)
- [“Reinstalling the OpenSolaris Operating System” on page 53](#)
- [“Downloading the OpenSolaris Operating System” on page 53](#)

---

# Before You Begin

Before you begin configuring the preinstalled OpenSolaris OS, do the following:

- Perform initial configuration of the server's ILOM and determine the server's network settings, as described in [Chapter 2](#).
- Gather the information that you will need for the configuration, as listed in ["Installation Worksheet" on page 44](#).

---

**Tip** – To find the server module, PCI ExpressModule, and SP MAC addresses, see the Customer Information Sheet included with the system box, or see the server, PCI EM, and SP MAC addresses printed on their respective labels.

---

## Installation Worksheet

Use the worksheet in [TABLE 4-1](#) to gather the information that you need to configure the preinstalled OpenSolaris OS. You need to collect only the information that applies to your application of the system.



**TABLE 4-1** Worksheet for OpenSolaris Configuration

Information for Installation		Description or Example	Your Answers: Defaults (*)
Language		Select from the list of available languages for the OpenSolaris software.	English*
Locale		Select your geographic region from the list of available locales.	
Terminal		Select the type of terminal that you are using from the list of available terminal types.	
Network connection		Is the system connected to a network?	<ul style="list-style-type: none"> <li>• Networked</li> <li>• Non-networked*</li> </ul>
DHCP		Can the system use Dynamic Host Configuration Protocol (DHCP) to configure its network interfaces?	<ul style="list-style-type: none"> <li>• Yes</li> <li>• No*</li> </ul>
If you are not using DHCP, note the network address:	IP address	If you are not using DHCP, supply the IP address for the system. Example: 129.200.9.1	
	Subnet	If you are not using DHCP, is the system part of a subnet? If yes, what is the netmask of the subnet? Example: 255.255.0.0	255.255.0.0*
	IPv6	Do you want to enable IPv6 on this machine?	<ul style="list-style-type: none"> <li>• Yes</li> <li>• No*</li> </ul>
Host name		A host name that you choose for the system.	
Kerberos		Do you want to configure Kerberos security on this machine? If yes, gather the following information: <div style="text-align: right; margin-right: 50px;">                     Default realm:                      Administration server:                      First KDC:                      (Optional) Additional KDCs:                 </div>	<ul style="list-style-type: none"> <li>• Yes</li> <li>• No*</li> </ul>

**TABLE 4-1** Worksheet for OpenSolaris Configuration (*Continued*)

Information for Installation		Description or Example	Your Answers: Defaults (*)
Name service	Name service	If applicable, which name service should this system use?	<ul style="list-style-type: none"> <li>• NIS+</li> <li>• NIS</li> <li>• DNS</li> <li>• LDAP</li> <li>• None*</li> </ul>
	Domain name	Provide the name of the domain in which the system resides.	
	NIS+ and NIS	Do you want to specify a name server, or let the installation program find one?	<ul style="list-style-type: none"> <li>• Specify One</li> <li>• Find One*</li> </ul>
	DNS	<p>Provide IP addresses for the DNS server. You must enter at least one IP address, but you can enter up to three addresses.</p> <p>You can also enter a list of domains to search when a DNS query is made.</p> <p style="text-align: right;">Search domain: Search domain: Search domain:</p>	
	LDAP	<p>Provide the following information about your LDAP profile:</p> <p style="text-align: right;">Profile name: Profile server:</p> <p>If you specify a proxy credential level in your LDAP profile, gather the following information:</p> <p style="text-align: right;">Proxy-bind distinguished name: Proxy-bind password:</p>	

**TABLE 4-1** Worksheet for OpenSolaris Configuration (*Continued*)

Information for Installation	Description or Example	Your Answers: Defaults (*)
Default route	<p>Do you want to specify a default route IP address, or let the OpenSolaris Installation Program find one?</p> <p>The default route provides a bridge that forwards traffic between two physical networks. An IP address is a unique number that identifies each host on a network.</p> <p>You have the following choices:</p> <ul style="list-style-type: none"><li>• You can specify the IP address. An <code>/etc/defaultrouter</code> file is created with the specified IP address. When the system is rebooted, the specified IP address becomes the default route.</li><li>• You can let the OpenSolaris Installation Program detect an IP address. However, the system must be on a subnet that has a router that advertises itself by using the Internet Control Message Protocol (ICMP) for router discovery. If you are using the command-line interface, the software detects an IP address when the system is booted.</li><li>• You can select None if you do not have a router or do not want the software to detect an IP address at this time. The software automatically tries to detect an IP address on reboot.</li></ul>	<ul style="list-style-type: none"><li>• Specify One</li><li>• Detect One</li><li>• None*</li></ul>
Time zone	How do you want to specify your default time zone?	<ul style="list-style-type: none"><li>• Geographic region*</li><li>• Offset from GM</li><li>• Time zone file</li></ul>
Root password	Choose a root password for the system.	

---

# Configuring the Preinstalled OpenSolaris Operating System

---

**Note** – Before you perform this procedure, you need to set up the service processor. For instructions on setting up the service processor, see [Chapter 2](#).

---

Use the information that you gathered in “[Installation Worksheet](#)” on page 44 as you perform the configuration.

After configuring the server module ILOM, you can configure the preinstalled OpenSolaris Operating System by using the service processor to connect to the system console.

## ▼ To Configure the Preinstalled OpenSolaris OS

You can connect to the service processor using a serial terminal or the Ethernet, as described in “[Connecting to the Server Module ILOM](#)” on page 15.

If you connect to the service processor using a serial terminal, you can use one of the following options:

- To capture the serial port output, on a client running the OpenSolaris OS, type:  
`$tip -9600 /dev/ttya`
- On a client running the Windows OS, start a program such as Hyperterminal.
- On a client running the Linux OS, start a program such as Minicom, a text-based serial communication program that is included in the Linux distributions. For more information, see the man pages included in the Linux distribution.

1. **Connect and log in to the service processor using one of the methods described in “[Connecting to the Server Module ILOM](#)” on page 15.**

The server module ILOM CLI prompt appears:

```
->
```

2. Verify that the communication properties of the service processor are set to the defaults. For example:

```
-> show /SP/serial/host
/SP/serial/host
  Targets:

  Properties:
    commitpending = (Cannot show property)
    pendingspeed = 9600
    speed = 9600

  Commands:
    cd
    show
```

3. If the speed is anything other than 9600, change it by entering the command:  
-> **set /SP/serial/host pendingspeed=9600 commitpending=true**
4. Start the serial console mode by entering the following command:  
-> **start /SP/console**

---

**Note** – Only accounts with Administrator privileges are enabled to configure the SP.

---

5. When the prompt appears, type **y**:

Are you sure you want to start /SP/console (y/n)? **y**



---

**Caution** – Electrocutation or equipment damage possible if an electrically conductive object is used to activate the recessed Power button.

---

6. Turn on the server module by using a pointed non-conducting object or stylus to press the recessed Power button on the front panel.  
POST messages appear on your screen as the OS boots.
7. Follow the OpenSolaris preinstallation on-screen prompts.
8. Use the information gathered in [“Installation Worksheet” on page 44](#) to help you enter the system and network information as you are prompted.

The screens that are displayed vary, depending on the method that you selected for assigning network information to the server (DHCP or static IP address).

After you have entered the system configuration information, the server completes the boot process and displays the OpenSolaris login prompt.

## ▼ (Optional) To Redirect the Console Output to the Video Port

The server module's console is automatically directed to the serial port. GRUB, the open source boot loader, is the default boot loader in the OpenSolaris OS for x86-based or x64-based systems. The boot loader is the first software program that runs after you power on a system.

1. Use a cable to connect the serial port of the host server (either through the chassis SER MGT port or through a dongle cable's serial port) to the video port of the client system.
2. From the GRUB menu, you have the option of displaying the installation process to a VGA connection (video port) as shown here:

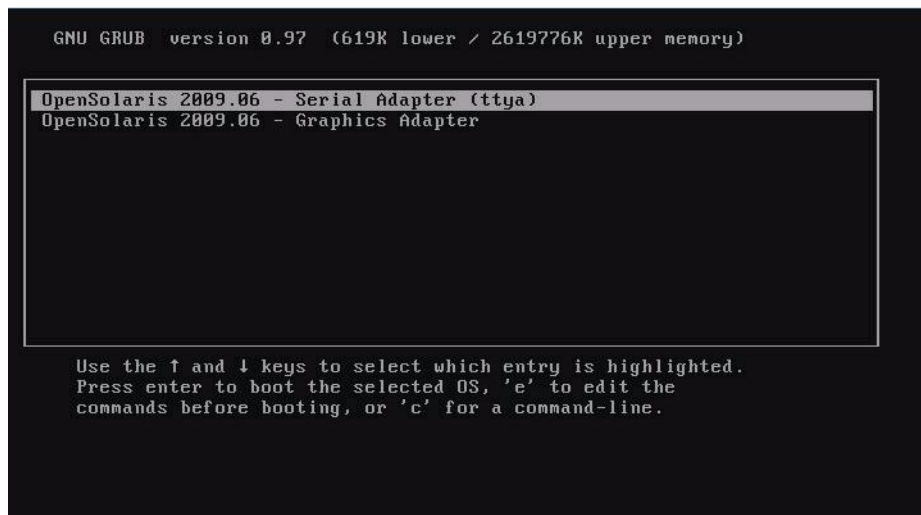

3. To display output to the video port, choose the following option:

```
OpenSolaris 2009.06 - Graphics Adapter
```

## ▼ To Modify the GRUB Menu to Auto Boot

The GRUB menu on the preinstalled image has been configured for an infinite timeout so that you can choose the console output on power-up. However, you can modify this setting so that your system boots automatically.

- To modify the GRUB menu to auto boot, edit the `/rpool/boot/grub/menu.lst` file as follows:

- a. **Change the `-1` value on the timeout line to reflect the duration you want the menu to be presented.**

For example, for a 10-second delay, set the `-1` on the timeout line to `10`.

- b. **Add a line that specifies the defaults boot entry.**

For example, to specify the first entry, set the defaults to `10`.

---

## Getting Started With the OpenSolaris Operating System

For information on getting started with OpenSolaris, click the Start Here icon on the OpenSolaris Desktop.

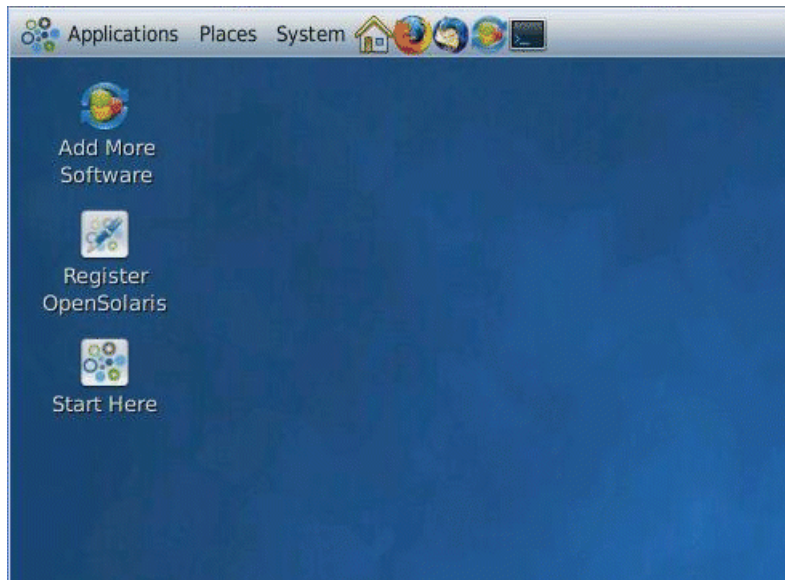

---

# OpenSolaris Operating System User Information

This section provides pointers to information about the OpenSolaris Operating System.

## OpenSolaris OS User Documentation

You can access the OpenSolaris user documentation at:

<http://opensolaris.org/os/documentation>

## OpenSolaris OS Training

For OpenSolaris training options, go to:

<http://www.opensolaris.com/learn/subscriptions/>

---

# Using the OpenSolaris Installation Program

Instructions for using the OpenSolaris installation program are available at the following web site:

<http://dlc.sun.com/osol/docs/content/2009.06/getstart/index.html>

After you configure the preinstalled OpenSolaris OS, the OpenSolaris installation program reboots the system and prompts you to log in.



---

# Reinstalling the OpenSolaris Operating System

If you want to reinstall the OpenSolaris OS or to install a different version of the OpenSolaris OS, refer to the *Getting Started With OpenSolaris 2009.06* at:

<http://dlc.sun.com/osol/docs/content/2009.06/getstart/>

---

# Downloading the OpenSolaris Operating System

You can download software for the OpenSolaris OS from the following sites:

- To download the OpenSolaris OS, go to:  
<http://opensolaris.org/os/TryOpenSolaris/>
- To download support repository updates (SRUs), which contain the latest released bug fixes for the OpenSolaris OS, go to:  
<http://sunsolve.sun.com/show.do?target=opensolaris>



# Index

---

## C

- chassis management module *see* CMM
- chassis, defined, 2
- CMM ILOM, 14
- CMM, defined, 2
- command line interface (CLI)
  - SSH log in, 22
  - SSH log out, 22
- compact flash card
  - defined, 2
  - installing, 4
  - removing, 10

## D

- default root password, 22
- driver updates, x
- Dynamic Host Control Protocol (DHCP), 27

## F

- firmware updates, x

## G

- GRUB menu, 40
  - modifying to auto boot system, 50
  - redirecting output to video port, 50

## I

- installation overview, 3
- installing a compact flash card, 4
- installing operating systems, 31
- Integrated Lights Out Manager (ILOM)

## CLI

- SSH log in, 22
- SSH log out, 22
- customizing, 31
- defined, 2
- introduction, 13
- serial connection, 16

## IP address

- configuring through BIOS Setup utility, 25
- configuring through DHCP, 27

## L

### LED

- Locate, 8
- Power, 8
- Ready to Remove, 7, 8, 9
- Service Action Required, 8

### log in

- CLI and SSH, 22

### log out

- CLI and SSH, 22

## M

- MAC address, 17, 27
  - server module, 34, 44
  - SP, 34, 44

## O

- OpenSolaris Operating System
  - configuring, 43
  - desktop window, 51
  - downloading, 53

- installation prerequisites, 44

- OpenSolaris OS
  - downloading, 53

- operating systems
  - configuring OpenSolaris OS, 48
  - preinstalled OS
    - configuring Solaris OS, 33
- overview of installation, 3

## **P**

- password, root, 22
- PCI EM MAC address, 34, 44
- Power LED, 8
- preconfigured ILOM Administrator account, 14
- product updates, x

## **R**

- Ready to Remove LED, 7, 9
- root password, 22

## **S**

- Secure Shell (SSH)
  - CLI log in, 22
  - CLI log out, 22
- serial port connector, 21
- server module
  - booting, 9
  - connecting through the SP IP address, 38, 48
  - front panel, 8
  - ILOM, 14
  - inserting, 5
  - powering off, 9
  - powering on, 9
  - redirecting console to video, 40, 50
- server module defined, 2
- server module ILOM
  - connecting through chassis serial connector, 16
  - connecting through dongle cable, 20
  - connecting through the Ethernet port, 21
- service processor (SP)
  - defined, 2
  - MAC Address, 34, 44
- Solaris 10 Operating System
  - configuring, 33
  - downloading, 42
  - installation prerequisites, 34

- prerequisites, 34
- stand-by power mode, placing the server in, 7

## **T**

- terms defined, 2, 13, 14

## **U**

- USB device connection, 21

## **V**

- video port redirection, 40, 50