

# Quantum|ATL StackLink™ Installation Instructions

---

---

Introduction	3
StackLink Kit Contents .....	3
Required Tools.....	4
Preparing the Rack	5
Installing the Top Mounting Tray Assembly	7
Installing the Bottom Mounting Tray Assembly	9
Installing the Carriage/counterweight Assembly	11
Installing the Motor Assembly	12
Attaching the Shuttle Assembly to the Top and Bottom Mounting Tray Assemblies	15
Installing the Libraries	16
Installing the Safety Blanking Panels	18

---

Cabling the Library	18
Interlibrary (Control Bus) Cabling .....	19
StackLink Motor Connection .....	20
SCSI Bus Cabling.....	20
Power Cabling .....	22

---

Completing the Installation	24
Powering Up the Library .....	24
Configuring the Library .....	26
Testing the Library Robotics .....	27

# Introduction

This document explains how to install the Quantum | ATL StackLink™. The StackLink provides the physical connection between M1500 library modules in an M1500 stack, allowing each of the tape drives in the stack to have access to all of the data cartridges.

Before you start the StackLink installation procedure:

- Verify that the StackLink kit contains all of the necessary items (see the following section, [StackLink Kit Contents](#)).
- Make sure you have the necessary tools for the installation (see [Required Tools](#) on page 4).

## StackLink Kit Contents

[Table 1](#) lists the contents of the StackLink kit. If any items are missing, contact Quantum | ATL.

Table 1 Contents, StackLink Kit

Part No.	Description	Quantity Provided		
		w/ 2-high StackLink	w/ 5-high StackLink	w/ 10-high StackLink
214370/01	Top mounting tray assembly	1	1	1
214380/01	Bottom mounting tray assembly	1	1	1
214390/01	Vertical shuttle assembly (2 unit)	1	N/A	N/A
214400/01	Vertical shuttle assembly (5 unit)	N/A	1	N/A
214410/01	Vertical shuttle assembly (10 unit)	N/A	N/A	1
214450/01	Shuttle motor mount assembly	1	1	1
215180/01	Carriage/counterweight assembly	1	1	1
212579	Front safety blanking panel	N/A	3	8
212502	Rear safety blanking panel	N/A	3	8
214090/01	StackLink motor cable (.6 meter)	1	N/A	N/A
214080/01	StackLink motor cable (1 meter)	N/A	1	N/A
214070/01	StackLink motor cable (2 meter)	N/A	N/A	1

Part No.	Description	Quantity Provided		
		w/ 2-high StackLink	w/ 5-high StackLink	w/ 10-high StackLink
AS3642	Library control bus cable (.5 meter)	3	4	9
AS3643	Library control bus cable (2 meter)	N/A	2	2
6421009	<i>Quantum   ATL StackLink™ Installation Instructions</i>	1	1	1
YS40984	M4 x 8 Pozi-Driv countersink screw	3	3	3
YS40095	M4 x 8 Pozi-Driv pan head screw	1	1	1
YS41830	M2.5 x 6 Pozi-Driv countersink screw	2	2	2
YS42008	M6 caged nut	16	22	32
YS41803	M6 x 10 Pozi-Drive pan head screw	16	22	32
YS40404	M6 plain washer	16	22	32
YS40095	M4 x 8 Pozi-Driv pan head screw	N/A	6	16
YS40097	M4 x 12 Pozi-Driv pan head screws	6	6	6
YS40402	M4 plain washer	6	6	6

## Required Tools

The following tools are required to install the StackLink:

- Flat head screwdriver (for installing caged nuts)
- No. 1 Pozi-Driv® screwdriver
- No. 2 Pozi-Driv screwdriver

---

## Preparing the Rack

Before starting the StackLink installation, perform the following steps to prepare the rack for the installation procedure:

- 1 Verify that the distance between the front and rear mounting strips is between 25.5 inches and 32.25 inches (650 mm and 820 mm). If this is not the case, adjust the mounting strips referring to the instructions provided by the rack manufacturer.
- 2 Determine the correct placement of the StackLink in the rack (see [figure 1](#)).

The top mounting tray assembly should be installed in the 1U space just above where the uppermost library in the system will be installed.

**Note:** 1U equals 1.75 inches, or 44.45 millimeters.

The bottom mounting tray should be installed as follows:

- If you are installing a 2-high StackLink, allow 8U of space between the top and bottom mounting tray assemblies. The entire StackLink mechanism occupies 10U of space, 1U for the top mounting tray assembly, 8U for libraries, and 1U for the bottom mounting tray assembly.
- If you are installing a 5-high StackLink, allow 20U of space between the top and bottom mounting tray assemblies. The entire StackLink mechanism occupies 22U of space, 1U for the top mounting tray assembly, 20U for libraries, and 1U for the bottom mounting tray assembly.
- If you are installing a 10-high StackLink, allow 40U of space between the top and bottom mounting tray assemblies. The entire StackLink mechanism occupies 42U of space, 1U for the top mounting tray assembly, 40U for libraries, and 1U for the bottom mounting tray assembly.

**Caution:** Take rack stability into account when determining where to place the StackLink. If the M1500 stack will be the only equipment in the rack, it is recommended that you install the StackLink at the bottom of the rack.

- 3 Use a pencil to mark the correct position of the mounting tray assemblies on the rack rails.

Figure 1 Determining the Placement of the Mounting Tray Assemblies

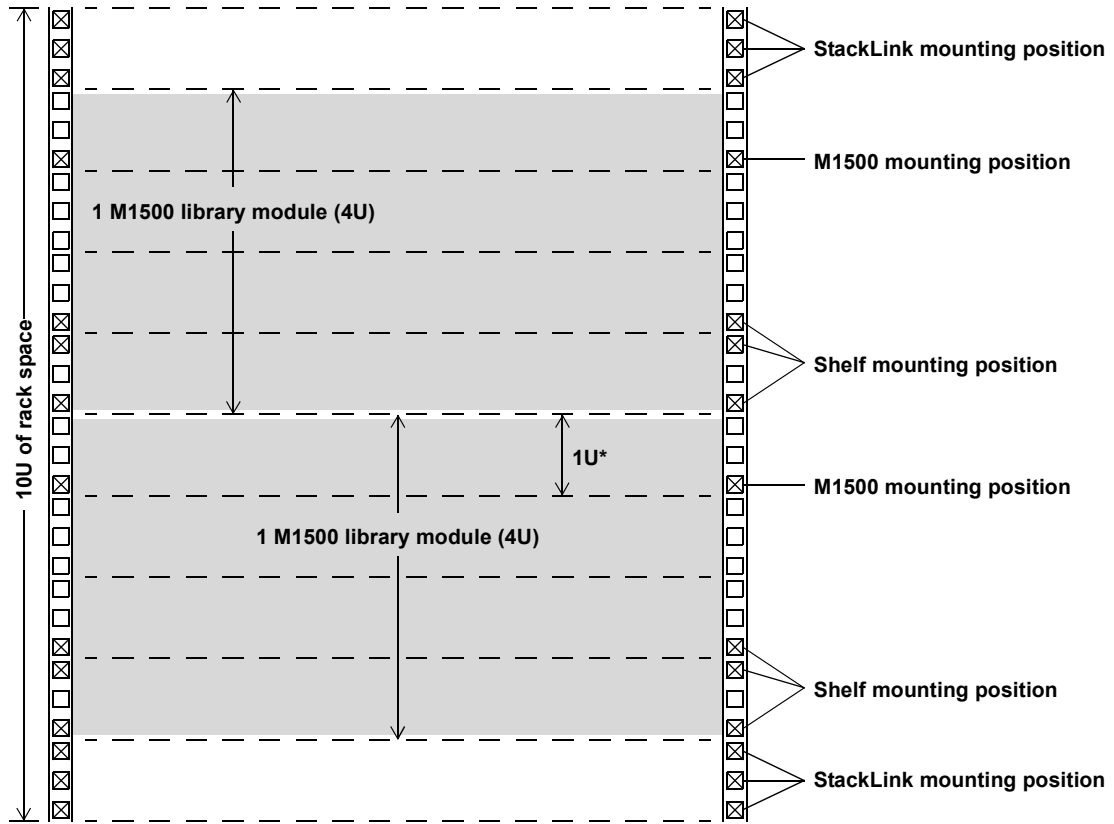

\*1U = 1.75 in (44.45 mm)

- 4 If the holes in the rack rails are square (untapped), insert caged nuts (PN YS42008) into the holes where the mounting tray assemblies will be installed (see [figure 2](#)).

Figure 2 Inserting Caged Nuts into the Rack Rails

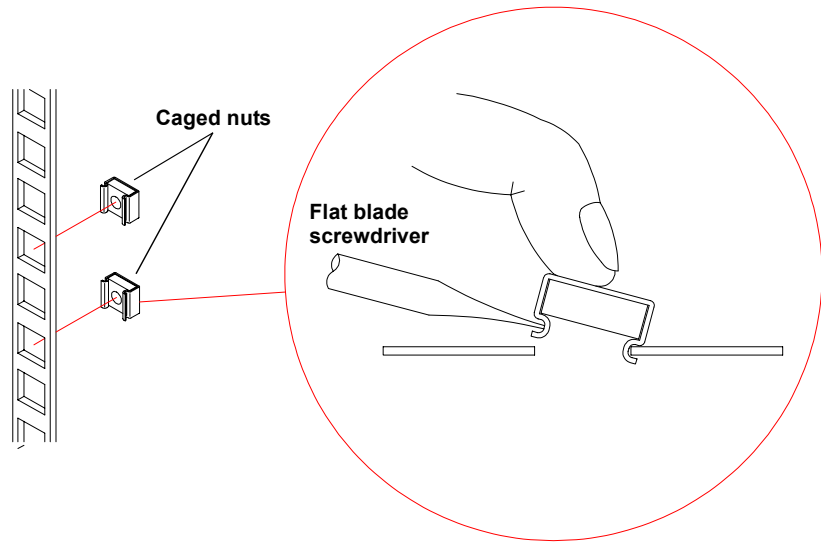

## Installing the Top Mounting Tray Assembly

To install the top mounting tray assembly in the rack:

- 1 Remove the six screws and washers securing the rear support arms to the sides of the top mounting tray (see [figure 3](#)).

Figure 3 Adjusting the Depth of the Top Mounting Tray Assembly

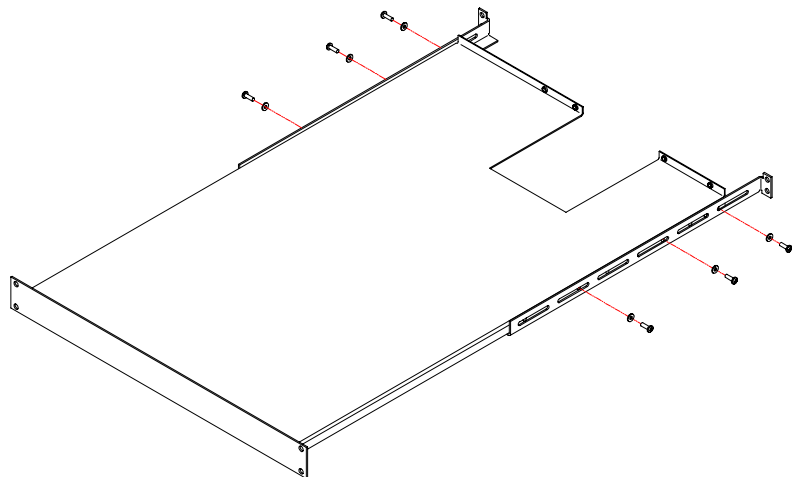

- 2 Adjust the position of the rear support arms on the top mounting tray until the distance between the front and rear flanges is approximately the same as the distance between the front and rear mounting strips in the rack.
- 3 Replace the six screws and washers you removed in [step 1](#) and finger-tighten them. Position the front and rear screws as far apart as the slots allow. Position the third screw approximately in the middle slot.

**Note:** Do not over-tighten the screws. You need to be able to extend or retract the rear support arms slightly as you install the top mounting tray assembly.

- 4 Position the top mounting tray assembly in the rack, referring to [figure 4](#) for the correct orientation.

**Note:** Position the front and rear flanges on the top mounting tray outside of the rack rails.

Figure 4 Securing the Top Mounting Tray Assembly to the Rack

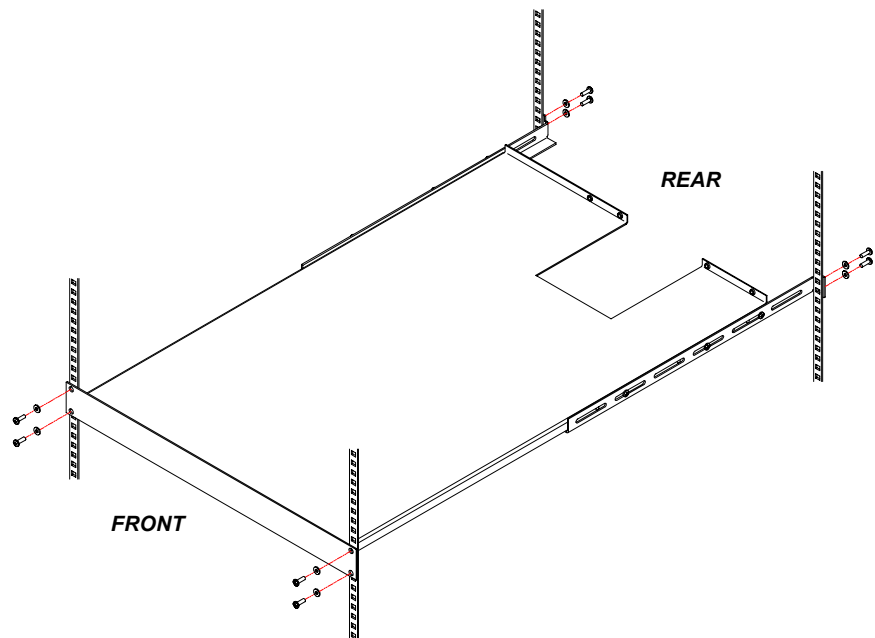



- 5 Secure the top mounting tray assembly to the rack, using eight screws (YS41803) and washers (YS40404) provided in the StackLink kit (see [figure 4](#)).

**Note:** If the rack has widely spaced mounting holes, it may not be possible to use all four screws to secure the rear flanges. If this is the case, one screw per side at the rear is acceptable.

- 6 Fully tighten the six screws and washers securing the rear support arms to the sides of the top mounting tray.

---

## Installing the Bottom Mounting Tray Assembly

To install the bottom mounting tray assembly in the rack:

- 1 Remove the six screws and washers securing the rear support arms to the sides of the bottom mounting tray (see [figure 5](#)).

---

Figure 5 Adjusting the Depth of the Bottom Mounting Tray Assembly

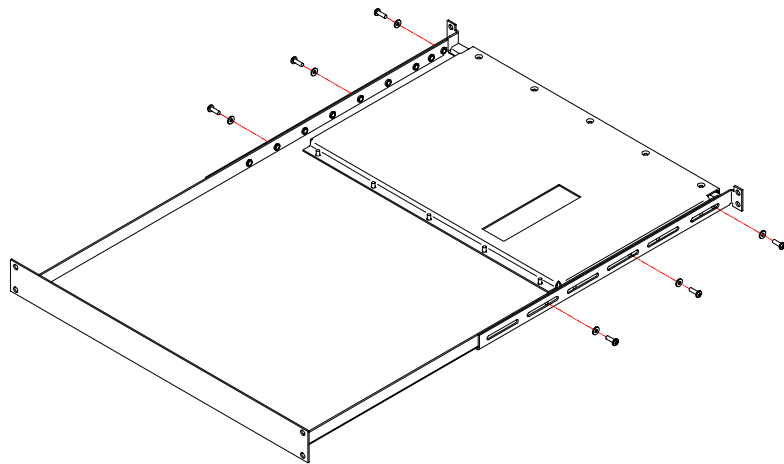

- 2 Adjust the position of the rear support arms on the bottom mounting tray until the distance between the front and rear flanges is approximately the same as the distance between the front and rear mounting strips in the rack.

- 3 Replace the six screws and washers you removed in [step 1](#) and finger-tighten them. Position the front and rear screws as far apart as the slots allow. Position the third screw approximately in the middle slot.

**Note:** Do not over-tighten the screws. You need to be able to extend or retract the rear support arms slightly as you install the bottom mounting tray assembly.

- 4 Position the bottom mounting tray assembly in the rack, referring to [figure 6](#) for the correct orientation.

**Note:** Position the front and rear flanges on the bottom mounting tray outside of the rack rails.

Figure 6 Securing the Bottom Mounting Tray Assembly to the Rack

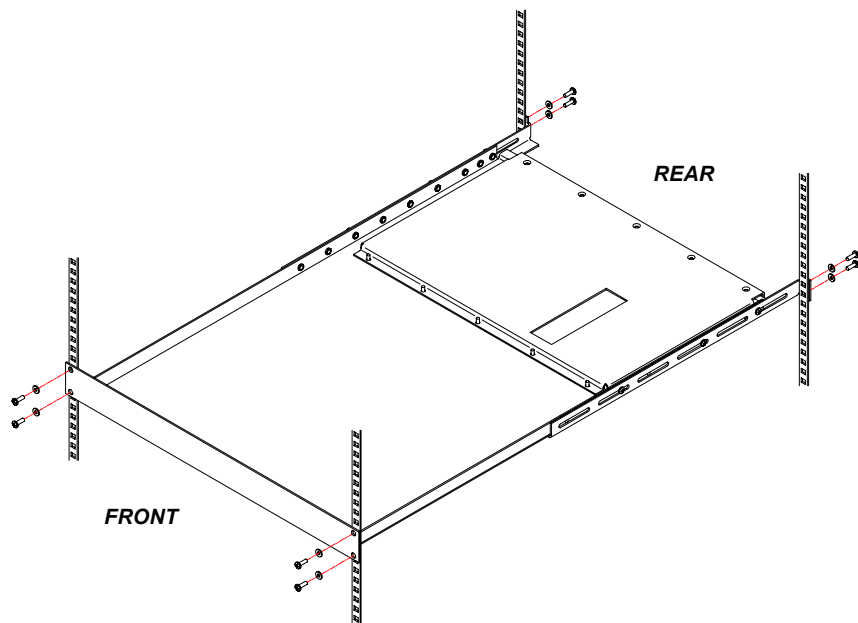

- 5 Secure the bottom mounting tray assembly to the rack, using eight screws (YS41803) and washers (YS40404) provided in the StackLink kit (see [figure 6](#)).

**Note:** If the rack has widely spaced mounting holes, it may not be possible to use all four screws to secure the rear flanges. If this is the case, one screw per side at the rear is acceptable.

- 6 Fully tighten the six screws and washers securing the rear support arms to the sides of the bottom mounting tray.

---

## Installing the Carriage/counterweight Assembly

Now that the top and bottom mounting tray assemblies are installed, install the carriage/counterweight assembly on the vertical shuttle assembly (see [figure 7](#)):

- 1 Slide the counterweight onto the bottom of the vertical shuttle assembly, engaging the guide wheels of the counterweight with the vertical rails.

---

Figure 7 Installing the Carriage/counterweight Assembly

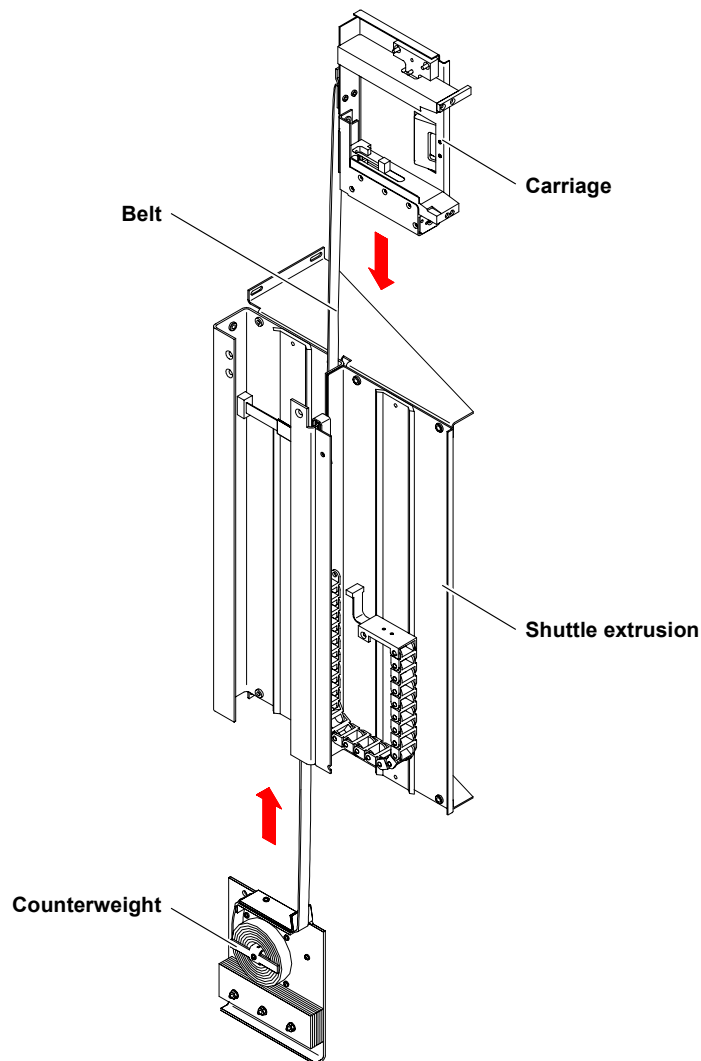

- 2 Route the belt connecting the counterweight and carriage up and over the top of the vertical shuttle assembly, making sure not to twist the belt.

- 3 Slide the carriage onto the top of the vertical shuttle assembly, engaging the guide wheels of the carriage with the vertical rails.
- 4 Secure the umbilical chain to the bottom of the carriage, using the two small countersink screws (YS41830) provided in the StackLink kit (see [figure 8](#)).
- 5 Connect the end of the umbilical cable to the socket on the carriage connection board (see [figure 8](#)).

Figure 8 Connecting the Umbilical Cable to the Bottom of the Carriage

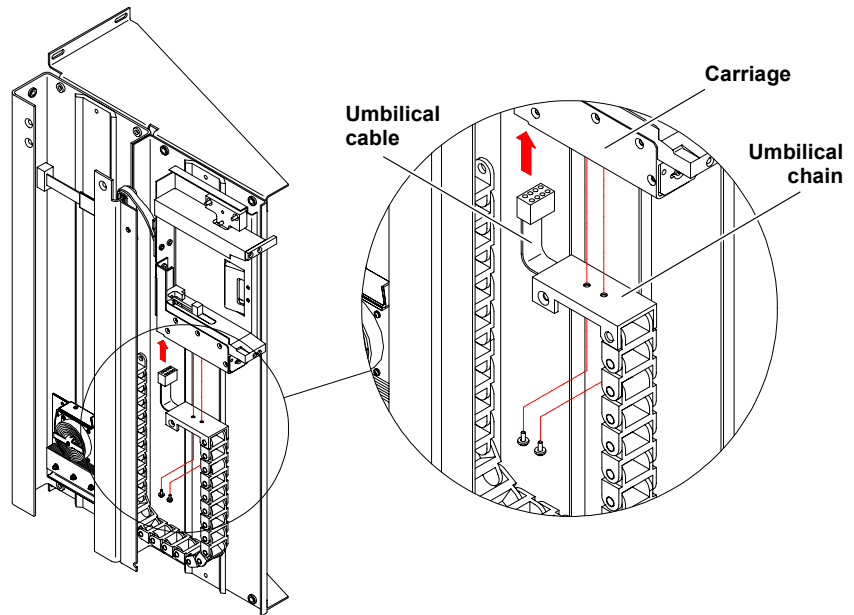

## Installing the Motor Assembly

To secure the motor assembly to the vertical shuttle assembly:

- 1 Insert the bottom of the motor assembly into the top of the vertical shuttle assembly, aligning the three holes in the vertical shuttle assembly with those on the motor assembly (see [figure 9](#)).

Figure 9 Inserting the Motor Assembly into the Vertical Shuttle Assembly

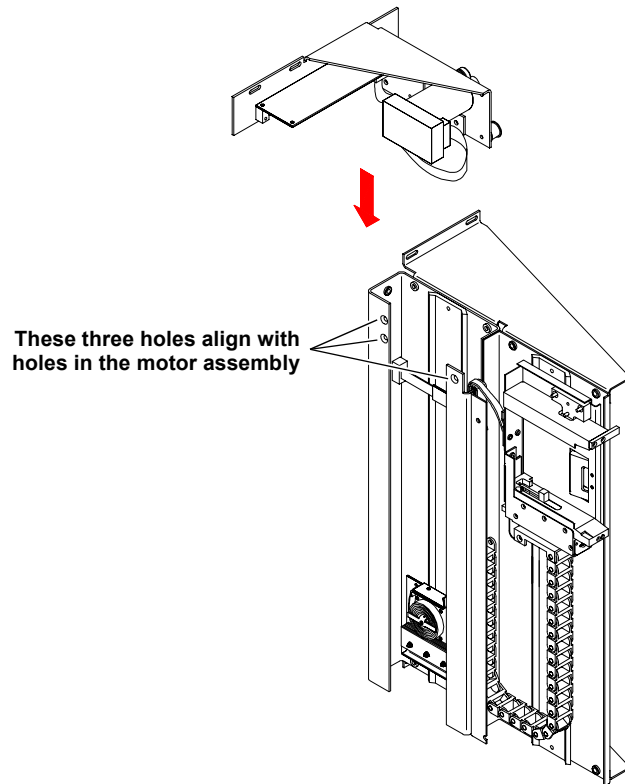

- 2 Secure the motor assembly to the vertical shuttle assembly, using three countersink screws (YS40984) and one pan head screw (YS40095) (see [figure 10](#)).

Figure 10 Securing the Motor Assembly to the Vertical Shuttle Assembly

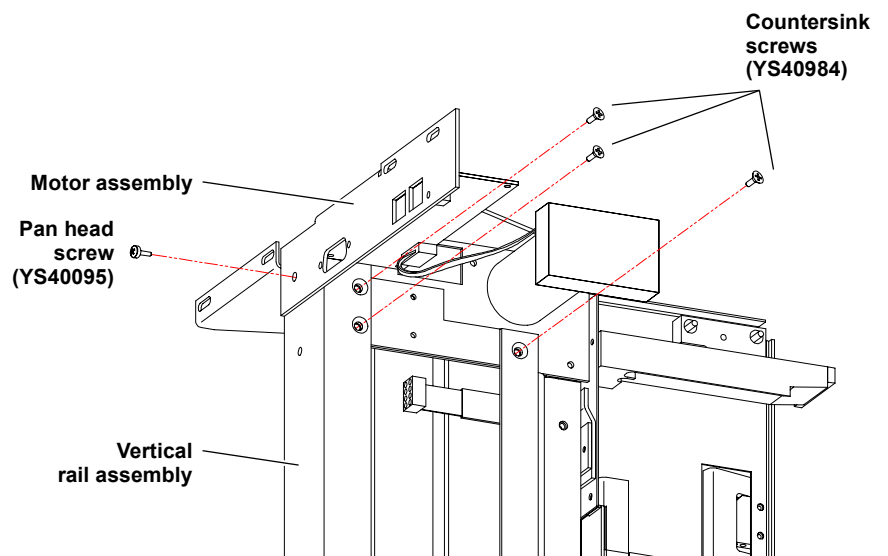

- 3 Route the belt connecting the counterweight and the carriage over the guide roller and past the motor/pulley belt retainer on the motor assembly (see [figure 11](#)).

Figure 11 Routing the Belt

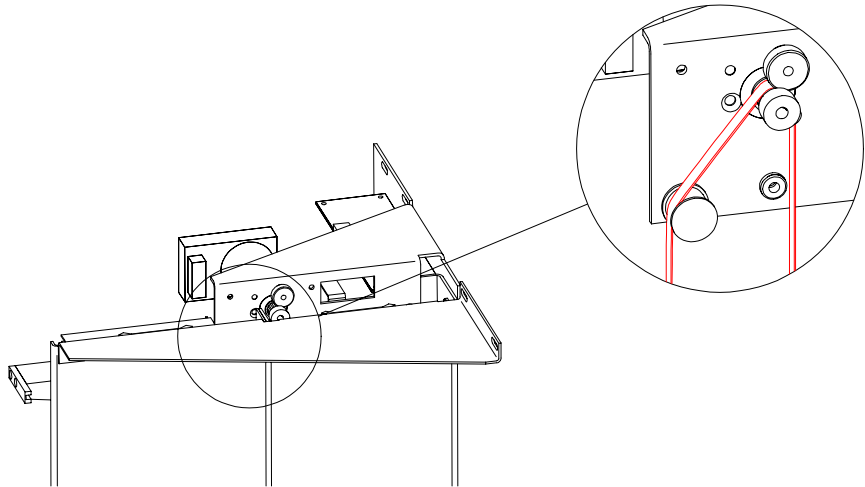

- 4 Connect the ribbon cable from the vertical shuttle assembly to the socket on the control board at the rear of the motor assembly as shown in [figure 12](#):
  - a Route the ribbon cable behind the motor plate.
  - b Insert the ribbon cable connector through the rectangular hole at the top of the motor plate.
  - c Connect the ribbon cable connector to the socket on the control board.

Figure 12 Connecting the Ribbon Cable

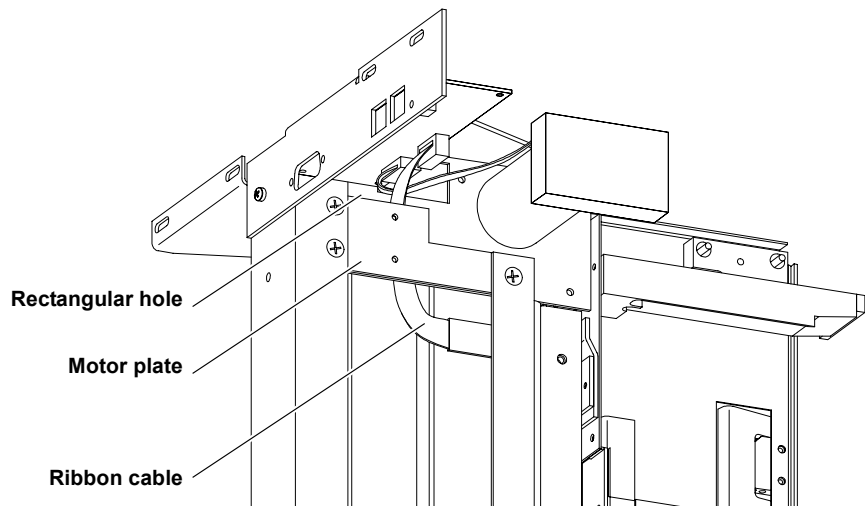

## Attaching the Shuttle Assembly to the Top and Bottom Mounting Tray Assemblies

To attach the shuttle assembly to the top and bottom mounting tray assemblies:

- 1 At the rear of the rack, lift the shuttle assembly and position it so the carriage faces forward into the rack.
- 2 Rest the lower end of the shuttle assembly on top of the bottom mounting tray assembly.
- 3 Ensure that the motor at the top of the shuttle assembly is aligned with the cutout in the top mounting tray assembly.
- 4 Slide the shuttle assembly fully into the rack.
- 5 Secure the shuttle assembly to the upper and lower mounting trays using six screws (YS40097) and washers (YS40402) provided in the StackLink kit (see [figure 13](#)).

**Note:** Tighten these screw to finger-tightness only. You will finish securing the StackLink after you have installed libraries in the rack.

Figure 13 Installing the Shuttle Assembly

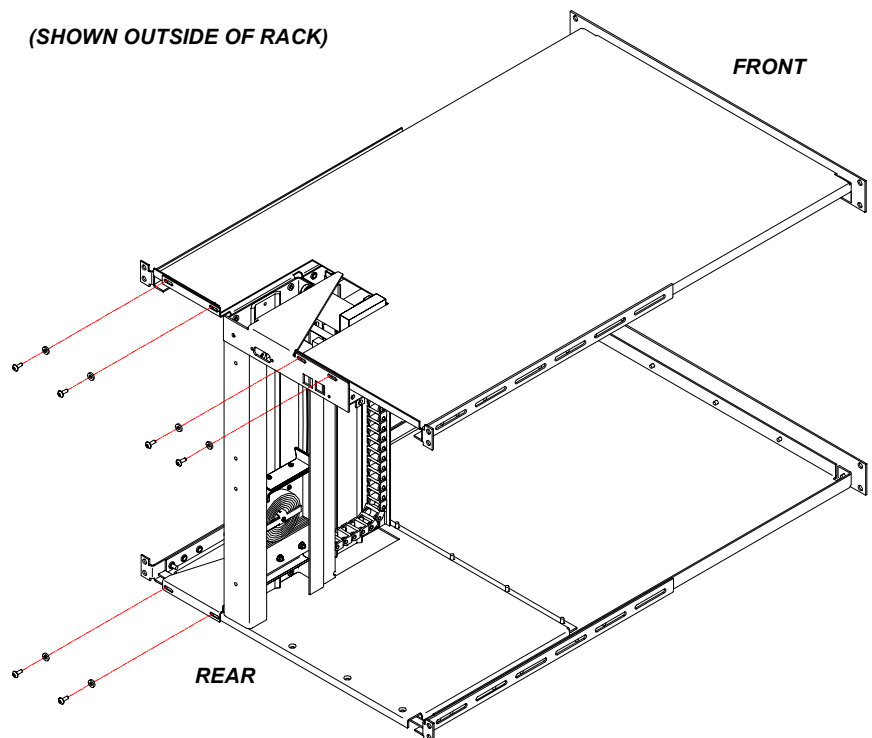

---

## Installing the Libraries

Now that the StackLink is installed in the rack, install the libraries as follows:

- 1 If you have not done so already:
  - a Unpack and install the rack mount shelves on which the M1500 libraries will be placed, referring to the *Quantum | ATL M1500 Universal Rack Mount Kit Installation Instructions* (PN 6421004).

**Note:** The libraries will be installed from the top of the rack downward; position the rack mount shelves accordingly. For example, if you were installing two libraries in a 5-high StackLink, you would install two sets of rack mount shelves: one set 4U below the StackLink top mounting tray assembly, and another set 8U below the StackLink top mounting tray assembly.

- b Unpack the M1500 libraries, referring to the *Quantum | ATL M1500 Library Unpacking Instructions* (PN 6421002).

**Caution:** Make sure to remove the StackLink cover plate from the rear of the libraries.

- 2 Install an M1500 library in the top StackLink position.
  - a Verify that the rack mount shelves are level and securely fastened to the rack.
  - b With the help of another person, lift the library onto the rack mount shelves.

**Caution:** When sliding the library into the rack, be very careful not to abrade or disconnect the ribbon cable that connects the vertical shuttle assembly to the control board on the motor assembly. See [figure 12](#) on page 14 for the location of this cable.

- c Slide the library all the way into the rack.



- d Press the white button next to the left magazine access door and open the door.
- e Notice the hole behind the magazine access door, at the lower edge of the library (see [figure 14](#)).

This hole provides access to the rack mount clamp screw.

Figure 14 Securing the Library to the Rack

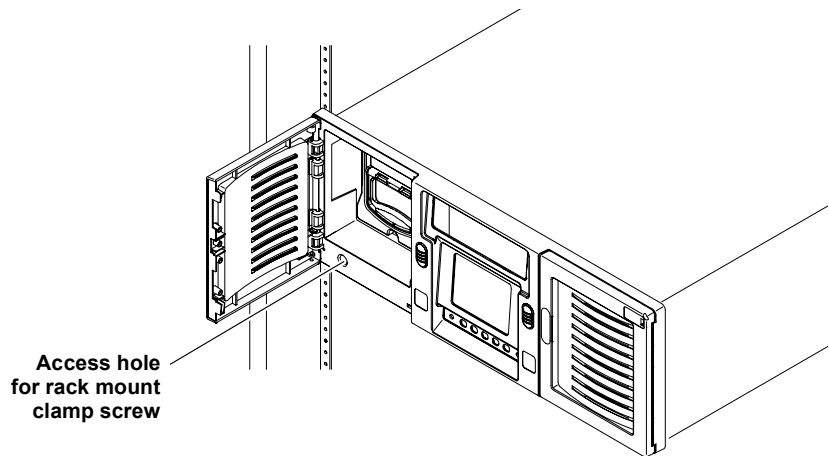

- f Insert a no. 2 Pozi-Driv screwdriver into the hole and turn the rack mount clamp screw clockwise to tighten it fully.  
As you tighten this screw, a lever protrudes from the side of the library and presses against the rear side of the rack rail.
  - g Repeat steps [2d](#) through [2f](#) to secure the right side of the library to the rack.
  - h Close the magazine access doors.
- 3 Repeat steps [2a](#) through [2h](#) to install additional M1500 library modules below the first one.

**Note:** Install the libraries from the top of the StackLink downward, leaving no space between the libraries. The cable lengths are designed for libraries installed immediately adjacent to one another.

- 4 Once all the libraries are installed, fully tighten the StackLink vertical shuttle assembly (see [figure 13](#) on page 15).

---

## Installing the Safety Blanking Panels

To avoid personal injury or damage to the StackLink mechanism, install safety blanking panels over all empty locations in the M1500 stack.

- 1 If the holes in the rack rails are square (untapped), insert caged nuts into the holes where the front safety blanking panels will be installed.
- 2 Install front safety blanking panels (212579) at the front of the rack, securing each panel with two screws (YS41803) and washers (YS40404).
- 3 Install rear safety blanking panels (212502) at the rear of the rack, securing each panel with two screws (YS40095).

---

## Cabling the Library

The library cabling procedure consists of the following steps:

- Interlibrary (control bus) cabling
- StackLink motor connection
- SCSI bus cabling
- Power cabling

## Interlibrary (Control Bus) Cabling

The intelligent control bus allows the individual libraries in the rack to communicate. To connect this bus:

- 1 Connect the top M1500 module in the rack to the terminator on the front of the motor assembly, using one of the library control bus cables provided (PN AS3642).
- 2 Daisy chain the control bus as shown in [figure 15](#), using the library control bus cables provided (PN AS3642).

Figure 15 Library Control and StackLink Power Cabling

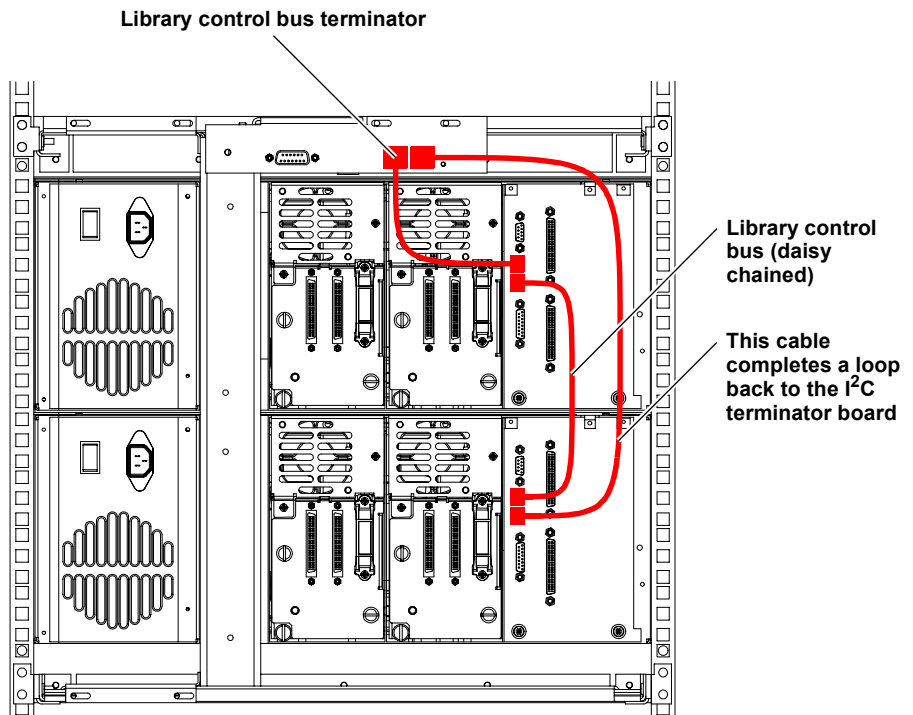

- 3 Connect the bottom M1500 module in the rack to the I<sup>2</sup>C terminator board:
  - On a 2-high stack, use library control bus cable PN AS2642.
  - On a 5-high or 10-high stack, use library control bus cable PN AS2643.

---

### StackLink Motor Connection

Once you have completed the interlibrary cabling, connect the StackLink motor cable (PN 214090/01, 214080/01, or 214070/01) from the StackLink motor to the StackLink motor drive on any of the library modules (see [figure 16](#)).

**Note:** The library module that is connected to the StackLink motor becomes the GUI master.

---

Figure 16 StackLink Motor Connection

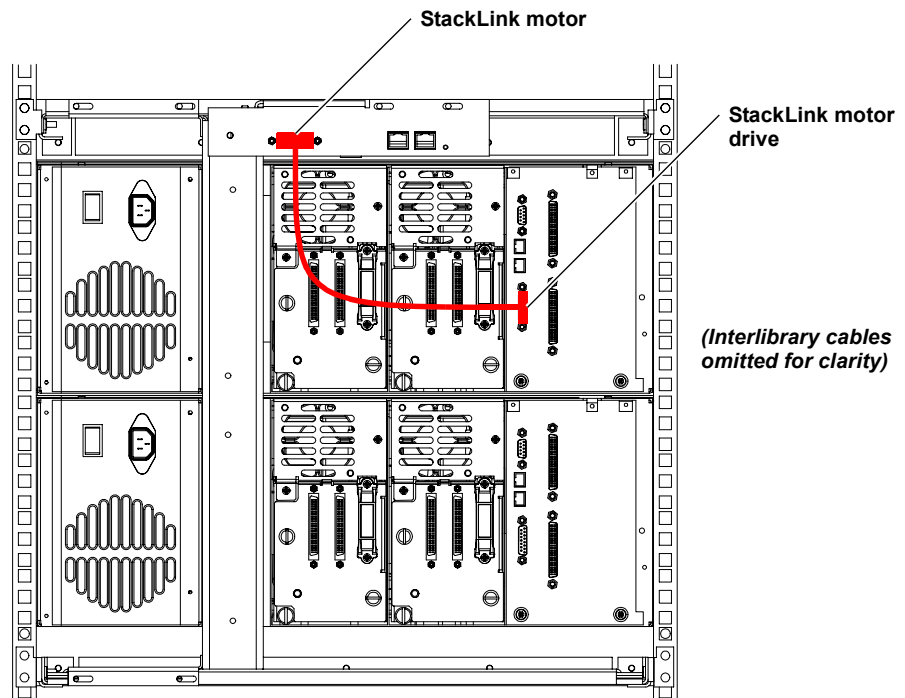

---

### SCSI Bus Cabling

Install the SCSI cabling, referring to [figure 17](#) and the SCSI and termination guidelines on page 21.

**Note:** Notice that the host computer is connected to the robotics connector on only one of the M1500 library modules. This library module is called the SCSI master.

Figure 17 Typical SCSI  
Bus Connections

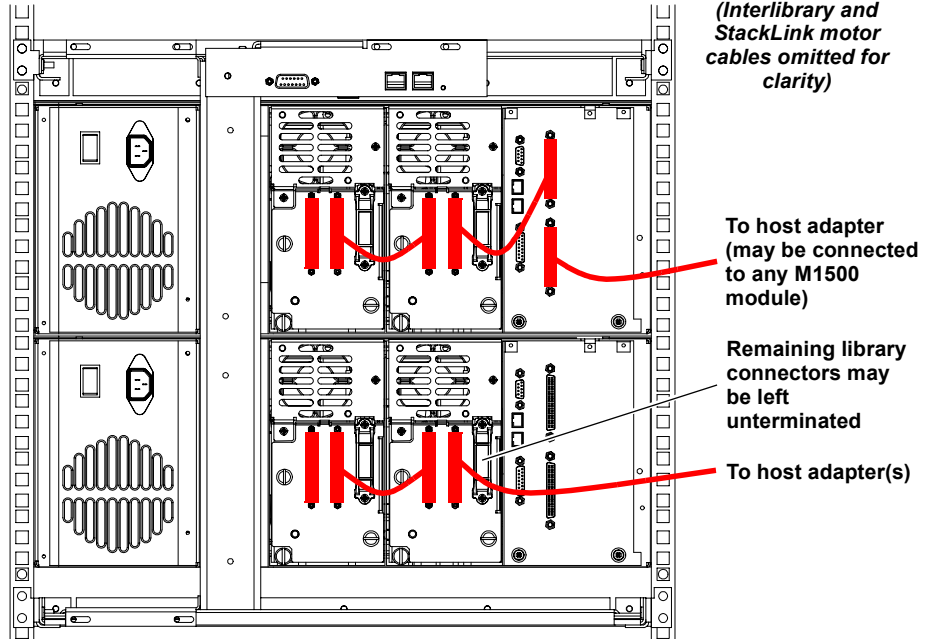

The number of drives per bus is determined by the data transfer performance of the host and drives.

### SCSI Cabling Guidelines

Refer to these SCSI cabling guidelines when completing the SCSI cabling:

- Each device on the SCSI bus must have a unique SCSI ID. The default settings are: library robotics = 0, tape drive 1 = 1, tape drive 2 = 2. You can change these SCSI ID settings using the **Drive ID** and **Library ID** options on the GUI **Configuration** screen.
- Termination must be provided at each end of the SCSI bus (see [Terminator Power](#)).
- Do not mix low voltage differential (LVD) and high voltage differential (HVD) SCSI devices on the same bus. Ensure that the host adapters match the devices on the bus.
- All SCSI cables must be shielded or double shielded to meet EMI specifications.
- The maximum total SCSI bus length for an LVD SCSI bus is 40 feet (12 meters).
- The maximum total SCSI bus length for an HVD SCSI bus is 82 feet (25 meters).

### Terminator Power

External terminators must be installed at the end of each SCSI bus. Power for the terminator must be supplied by at least one device on the SCSI bus.

In the factory default configuration, the library robotics supplies terminator power. You can turn this terminator power off using the **Terminator Power** option on the GUI **Configuration** screen.

### Power Cabling

To connect the library to AC power:

- 1 Referring to [table 2](#), select appropriate AC distribution unit(s) for your library configuration and input voltage.

**Warning:** AC distribution units (power strips) must be certified for safety by an agency acceptable to the country of use. For use in the United States and Canada, distribution units must be UL listed and CSA certified. For use in Europe, distribution units must be CE marked. National certifications for other countries depend on local requirements.

Table 2 AC Distribution Unit Requirements, 200V to 240V

# of Library Modules	Distribution Unit Requirements	
	200-240V 50-60Hz supply voltage (Europe & international, etc.)	100-120V 50-60Hz supply voltage (USA, Canada, Japan, etc.)
1-5	Connect libraries to one AC distribution unit rated minimum 10A, minimum 1.00mm <sup>2</sup> <HAR> cord with minimum 10A plug. Must be 3 wire grounding plug and wall outlet.	Connect libraries to one UL Listed AC distribution unit rated 15A or 20A, with a minimum 14AWG 3 wire cord, and a 15A or 20A plug. Must be 3 wire grounding plug and wall outlet.

# of Library Modules	Distribution Unit Requirements	
	200-240V 50-60Hz supply voltage (Europe & international, etc.)	100-120V 50-60Hz supply voltage (USA, Canada, Japan, etc.)
6-9	<p>Select one of the following options:</p> <ul style="list-style-type: none"> <li>Connect no more than 5 libraries to each of two AC distribution units rated minimum 10A, minimum 1.00mm<sup>2</sup> &lt;HAR&gt; cord with minimum 10A plug. Must be 3 wire grounding plug and wall outlet. The AC distribution units must be plugged into separate outlets served by separate circuit breakers or fuses.</li> <li>Connect all libraries to one AC distribution unit rated minimum 10A, minimum 1.00mm<sup>2</sup> &lt;HAR&gt; 3 wire cord with 3 wire IEC60309 rated 16A. Must be 3 wire grounding plug and wall outlet and have a ground warning label.</li> <li>Connect all libraries to one AC distribution unit rated minimum 10A, minimum 1.00 mm<sup>2</sup> &lt;HAR&gt; 3 wire cord permanently wired to the electrical supply. Must be connected with a 3 wire cable and have a ground warning label.</li> </ul>	<p>Select one of the following options:</p> <ul style="list-style-type: none"> <li>Connect no more than 5 libraries to each of two AC distribution units rated 15A or 20A, with a minimum 14AWG 3 wire cord, and a 15A or 20A plug. Must be 3 wire grounding plug and wall outlet. The AC distribution units must be plugged into separate outlets served by separate circuit breakers or fuses.</li> <li>Connect all libraries to one AC distribution unit rated 20A, with a minimum 14AWG 3 wire cord, with a 20A plug. Must be 3 wire grounding plug and wall outlet.</li> <li>Connect all libraries to one AC distribution unit rated minimum 20A, with a minimum 14AWG 3 wire cord, permanently wired to the electrical supply.</li> </ul>
10	Same requirements as 6-9 above.	Same requirements as 6-9 above, but the AC power distribution unit must also have a ground warning label.

2 Connect the power cable (provided in the library accessories kit) to the power inlet on the back of the library (see [figure 18](#)) and to the AC distribution unit.

Figure 18 Power Inlet

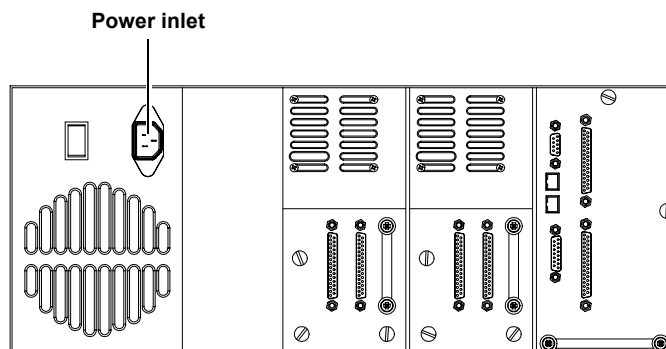

---

## Completing the Installation

To complete the StackLink installation:

- Power up the library
- Configure the library
- Test the library robotics

---

### Powering Up the Library

To power up the library, press the power switch on the back panel of the library (see [figure 19](#)).

**Caution:** To minimize the effects of inrush current, always turn on the library using this library power switch instead of using the power switch that may be on the AC distribution unit.

---

Figure 19 Power Switch

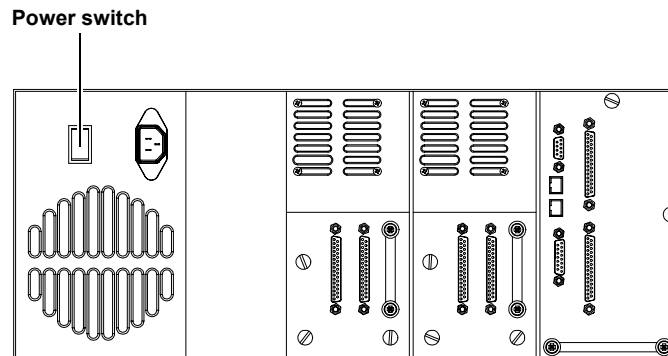

The GUI displays a welcome screen (see [figure 20](#)) and the library runs a power-on self-test (POST).



Figure 20 Welcome Screen

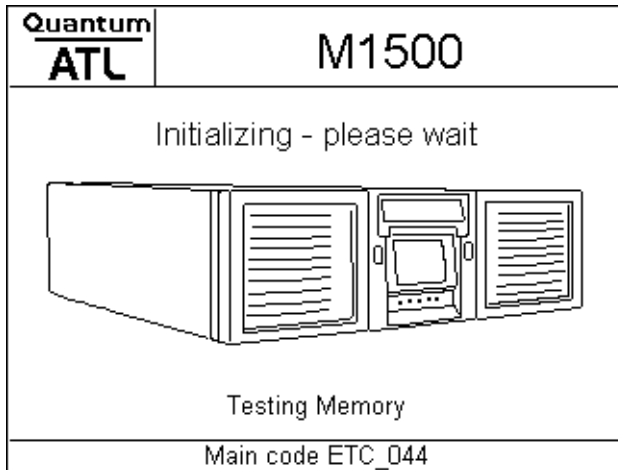

When the POST is complete, the GUI displays the main screen (see [figure 21](#)), where 1500 - x0 Ready should indicate the maximum size of the library, such as 1500 - 40 or 1500 - 100.

**Note:** If any of the library module main screens indicates 1500 Ready, then that particular library module has not been recognized as part of the M1500 stack. Check the interlibrary and StackLink motor cabling.

Figure 21 Sample Main Screen

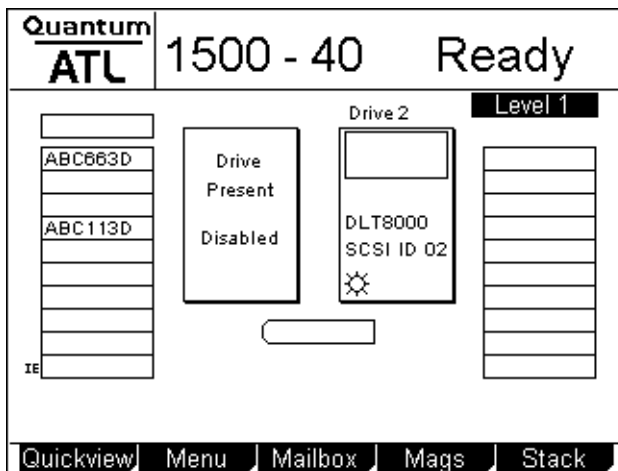

---

## Configuring the Library

Library configuration works somewhat differently in an M1500 stack than it does in a single library module.

**Note:** The library must be power cycled before any configuration changes will take effect.

### SCSI Import/Export Elements

To configure SCSI import/export elements using the **Import/Export** option, you must use the GUI on the GUI master. See the *Quantum | ATL M1500 Library User's Guide* (PN 6421000) for more information about this option.

**Note:** The GUI master is the library module that is connected to the StackLink motor (see [figure 16](#) on page 20).

**Caution:** Although the **Import/Export** option appears on the GUIs of all of the library modules, it is only functional on the GUI master.

### Tape Drive SCSI IDs

To set tape drive SCSI IDs, use the GUI on the library module that contains the tape drives you wish to affect. For example, the addresses of tape drives installed in library level 2 should be set from the GUI on library level 2.

### Library SCSI Settings

The SCSI host can be connected to any of the library modules. The SCSI settings for the M1500 stack (SCSI ID, emulation mode, etc.) are determined by the settings of the library module that is connected to the host (the SCSI master).

If you change the SCSI settings from the defaults, it is recommended that you change all library modules to the same settings.

---

## Testing the Library Robotics

To complete the installation, run the **Demo 5** program to verify that the StackLink robotics are working correctly:

- 1 Select a library module on which to initiate the test.
- 2 Load a single data cartridge into the left magazine of the selected M1500 module.

Leave all other slots in the M1500 stack empty.

- 3 On the GUI main screen of the selected M1500 module, press **Menu**.

The GUI displays the **Menu** screen (see [figure 22](#)).

---

Figure 22 Menu Screen

Quantum ATL	Menu
Move:	Move cartridges within library
Configuration:	Library, Drive and SCSI configuration
Service:	Library Statistics, Maintenance & Diagnostics
Demo:	Library demonstration programs

Main Move Config Service Demo

- 4 Press **Demo**.

The GUI displays the **Demo Programs** screen (see [figure 23](#)).

---

Figure 23 Demo Programs Screen

Quantum ATL	Demo Programs
<u>T</u> est	<u>D</u> escription
Confidence Test	
Demo 1	Move Cart, Random Selection
<b>Demo 2</b>	<b>Move Cart, Sequential Selection</b>
Demo 3	Same slot, Random Selection
Demo 4	Stack Move, Random Selection
Demo 5	Stack Move, Forced level change
Demo 6	Move to Location, Random Sel

Main Up Down Select Back

**5** Press the **Up** or **Down** buttons to select **Demo 5**.

**6** Press **Select**.

The **Demo 5** program starts. The program moves the data cartridge randomly between levels until you stop the program. It is recommended that you allow the program to run for five times the number of levels in the library; for example, a ten level stack should be run for at least 50 cycles.

**7** Ensure that all levels are accessed by observing the cartridges moving from level to level. If not, re-check the interlibrary cabling.

**8** When the program has run successfully for the recommended number of cycles, press **Stop** to end the program.

The GUI stops when the current cycle is completed.

The StackLink installation is now complete.